

SHOP MANUAL

HONDA 50 SERIES
MODELS C50,C50M AND S50

HONDA 65 SERIES
MODELS C65,C65M AND S65



SHOP MANUAL

HONDA 50 SERIES

MODELS C50, C50M AND S50

HONDA 65 SERIES

MODELS C65, C65M AND S65

FOREWORD

This is your maintenance and servicing guide for the Honda 50 series models C50, C50M and S50, and the Honda 65 series models C65, C65M and S65.

By following the clearly described and illustrated instructions contain herein, the proper servicing can be realized with relative simplicity. Not only will it serve the servicemen but this manual will be a valuable reference to the salesman by providing him with the general description of the motorcycle as well as the details of the various systems.

The servicing referred to here is to mean the diagnosis of any trouble spot and its repair to return it to the normal operating condition, and the periodic inspection and preventative maintenance to always keep the motorcycle functioning in the peak condition.

This manual is divided into eight main groups and each group being further divided into sections. The respective sections are organized into the construction, disassembly, inspection, servicing and reassembly. By following the procedures outlined in this manual, proper and thorough servicing is assured.

In preparing this publication, the theory and principle of operation have been omitted so that more space could be allotted to the description of the construction and configuration. Further, the emphasis is placed on pictorial representation by the use of photographs and drawing to clearly illustrate the respective components without resorting to lengthy wordily descriptions.

August 10, 1966

HONDA MOTOR CO., LTD.

Foreign Service Department
Service Division

TABLE OF CONTENTS

1. FEATURES	1
A. Engine	1
B. Frame (C50, C50M, C65, C65M)	3
C. Frame (S50, S65).....	5
2. SPECIAL TOOLS	6
1. Tools Necessary for <i>Disassembly and Reassembly of the Engine.</i>	6
2. Tools Necessary for <i>Disassembly and Reassembly of the Frame.</i>	7
3. ENGINE	
3.1 Engine	9
1. Engine Description	11
2. Power Transmission System	11
3. Engine Removal and Installation.....	11
a. Removal.....	11
b. Installation.....	12
4. Lubrication System	13
5. Oil Pump Principle	13
a. Disassembly	13
b. Inspection	14
c. Reassembly	14
3.2 Cylinder Head	14
1. Cylinder Head Design	14
a. Disassembly	15
b. Inspection and repair	16
c. Reassembly	16
2. Valve Seat Contact Surface	17
3. Inspection of Valve Contact Area.....	17
4. Camshaft.....	18
a. Inspection	20
5. Cylinder	20
a. Disassembly	20
b. Inspection	21
c. Reassembly	21
6. Piston	21
7. Piston Ring	22
a. Disassembly	23
b. Piston and Piston Ring Inspection.....	23
c. Reassembly	25
8. Valve Operating Mechanism	25
a. Disassembly	25
b. Inspection	25
c. Reassembly	26
9. Cam Chain Tensioner.....	26

a. Disassembly	27
b. Inspection	27
c. Reassembly	27
3.3 Right Crankcase Cover	27
a. Disassembly	28
b. Reassembly	28
1. Clutch	28
a. Disassembly	29
b. Inspection	29
c. Reassembly	30
2. Crankcase	30
3. Breather	30
3.4 Crankshaft	31
a. Disassembly	31
b. Inspection	32
c. Reassembly	33
3.5 Transmission	33
a. Disassembly	34
b. Inspection	34
c. Reassembly	35
3.6 Kick Starter	35
a. Disassembly	36
b. Inspection	36
c. Reassembly	36
3.7 Carburetor (C50, C50M, C65, C65M)	37
1. Air System	38
2. Fuel System	38
a. Main system	38
b. Slow system	39
3. Float Chamber	39
4. Choke (Starting)	39
5. Function of the Respective Components	40
a. Main jet	40
b. Air jet	40
c. Needle jet	40
d. Jet needle	41
e. Throttle valve	41
f. Slow jet	41
g. Air screw	42
6. Adjusting the Carburetor	42
a. High speed adjustment	42
b. Adjusting the intermediate speed	42
c. Adjusting the slow speed	43
d. Adjusting the idle	43

3.8	Carburetor (S50, S65)	44
1.	Air Flow	44
2.	Fuel Flow	44
a.	Main system	44
b.	Slow system	45
3.	Float Chamber	45
4.	Choke (Starting system)	46
5.	Adjusting the Fuel Level	46
6.	Carburetor Setting Table	47
4.	FRAME	49
4.1	Handle	49
1.	Handle Construction	49
a.	Disassembly	49
b.	Inspection	49
c.	Reassembly	50
2.	Front Fork	50
a.	Disassembly	50
b.	Inspection	50
c.	Reassembly	50
4.2	Front Cushion	51
1.	Front Cushion Construction	51
a.	Disassembly	51
b.	Inspection	52
c.	Reassembly	52
4.3	Rear Cushion	52
1.	Rear Cushion Construction	53
a.	Disassembly	53
b.	Inspection	53
c.	Reassembly	53
4.4	Front Wheel	54
a.	Disassembly	54
b.	Inspection	55
c.	Reassembly	55
4.5	Rear Wheel	56
1.	Rear Wheel Construction	57
a.	Disassembly	57
b.	Inspection	57
c.	Reassembly	58
4.6	Braking System	59
a.	Disassembly	60
b.	Inspection	60
c.	Reassembly	60
4.7	Rear Fork Construction	61
a.	Disassembly	61
b.	Inspection	61
c.	Reassembly	62

4.8	Drive Chain.....	62
	a. Disassembly	62
	b. Inspection	62
	c. Reassembly	63
4.9	Air Cleaner	63
	1. Air Cleaner Construction	64
	a. Disassembly	64
	b. Inspection	64
	c. Reassembly	64
4.10	Frame Body.....	64
4.11	Muffler	65
5.	ELECTRICAL SYSTEM.....	67
5.1	Starting System	67
	1. Trouble Shooting and Repair.....	68
5.2	Charging System.....	69
5.3	Flywheel A.C. Generator and Ignition Coil.....	70
	1. A.C. Generator	70
	2. Table of Specifications and Performance	70
	3. Inspecting Sparking Performance	71
	4. Trouble Diagnosing the Flywheel Generator	72
5.4	Spark Advancer	72
5.5	Battery	73
	1. Construction	73
	2. Rating	73
	3. Instruction on Use and Servicing	74
	4. Servicing During Use	74
	5. Battery Charging Procedure	75
	6. Trouble Shooting and Preventative Maintenance	75
	7. Trouble Shooting and Corrective Action	76
5.6	Spark Plug	77
	1. Spark Plug Condition.....	77
	2. Heat Range of the Spark Plug.....	77
	3. Spark Plug Reach	78
	4. Spark Plug Gap.....	78
	5. Main Spark Plug Trouble and Corrective Action.....	79
5.7	Turn signal Lamp	79
	1. Installation Instruction.....	79
	2. Turn signal Trouble and Corrective Action	80
5.8	Headlight	80
	1. Headlight Trouble and Corrective Action.....	80
5.9	Horn	80
	Battery Installation	81
5.10	Selenium Rectifier	82
	Checking the Condition of the Selenium Rectifier	82
5.11	Speedometer	83
	1. Speedometer Trouble and Corrective Action	84

2. Inspecting Procedure	84
6. PERIODIC ADJUSTMENT	85
6.1 Maintenance Inspection	85
A. Engine Adjustment.....	85
1. Measuring Compression	85
2. Valve Tappet Adjustment	85
3. Ignition Timing Adjustment	86
4. Contact Points	88
5. Spark Plug Adjustment	88
6. Fuel Supply System.....	89
7. Fuel Strainer Cleaning	90
8. Oil Filter Screen Cleaning.....	90
9. Air Cleaner Cleaning.....	91
10. Clutch Adjustment	91
11. Carburetor Cleaning and Adjustment.....	92
B. Lubrication	93
1. Parts Not Requiring Periodic Oil Change or Lubrication.....	93
2. Engine Oil Change.....	93
3. Greasing	94
C. Drive Chain Adjustment	94
D. Brake Adjustment	95
1. Front Brake Adjustment	95
2. Rear Brake Adjustment	95
E. Muffler Cleaning	96
F. Spoke Torquing.....	96
G. Battery Inspection.....	96
H. Security Inspection of Parts (C50, C50M, C65, C65M)	97
I. Security Inspection of Parts (S50, S65)	98
6.2 Periodic Inspection and Servicing.....	99
A. Daily Inspection	99
B. Periodic Inspection	101
7. TROUBLE SHOOTING	103
1. Main Engine Troubles.....	103
2. Carburetor Trouble	105
3. Engine Noise	108
4. Steering System	108
5. Clutch System.....	109
6. Gear Change System.....	109
7. Suspensions	110
8. Brake System	110
9. Drive Chain	110
8. SPECIFICATIONS & PERFORMANCES	111
Specifications	111
Engine Performance Curve.....	115
Dimensional Drawing	120
Wiring Diagram	122

1. FEATURES

The engines installed on the Honda C50, C50M, C65, C65M, S65 and S50 models are of a newly design type incorporating an O.H.C. and manufactured with the most up-to-date facilities under the strictest of quality control; a rugged performing engine at low speed, quiet in operation, compactly designed and highly efficient with the lightness of a mopet yet possessing the performance and feel of a 70cc economical motorcycle.

The greater output ratio, the lightweight and ruggedness of the new frame is far superior than anything in the past and its improvement in driving performance and comfort is hard to excel.

Listed on the following pages are only few of the finer points.

A. ENGINE

1. OVERHEAD CAMSHAFT (O. H. C.)

The adaptation of the chain driven O.H.C. affords uniform output extending from the low to the high speed range without effort.

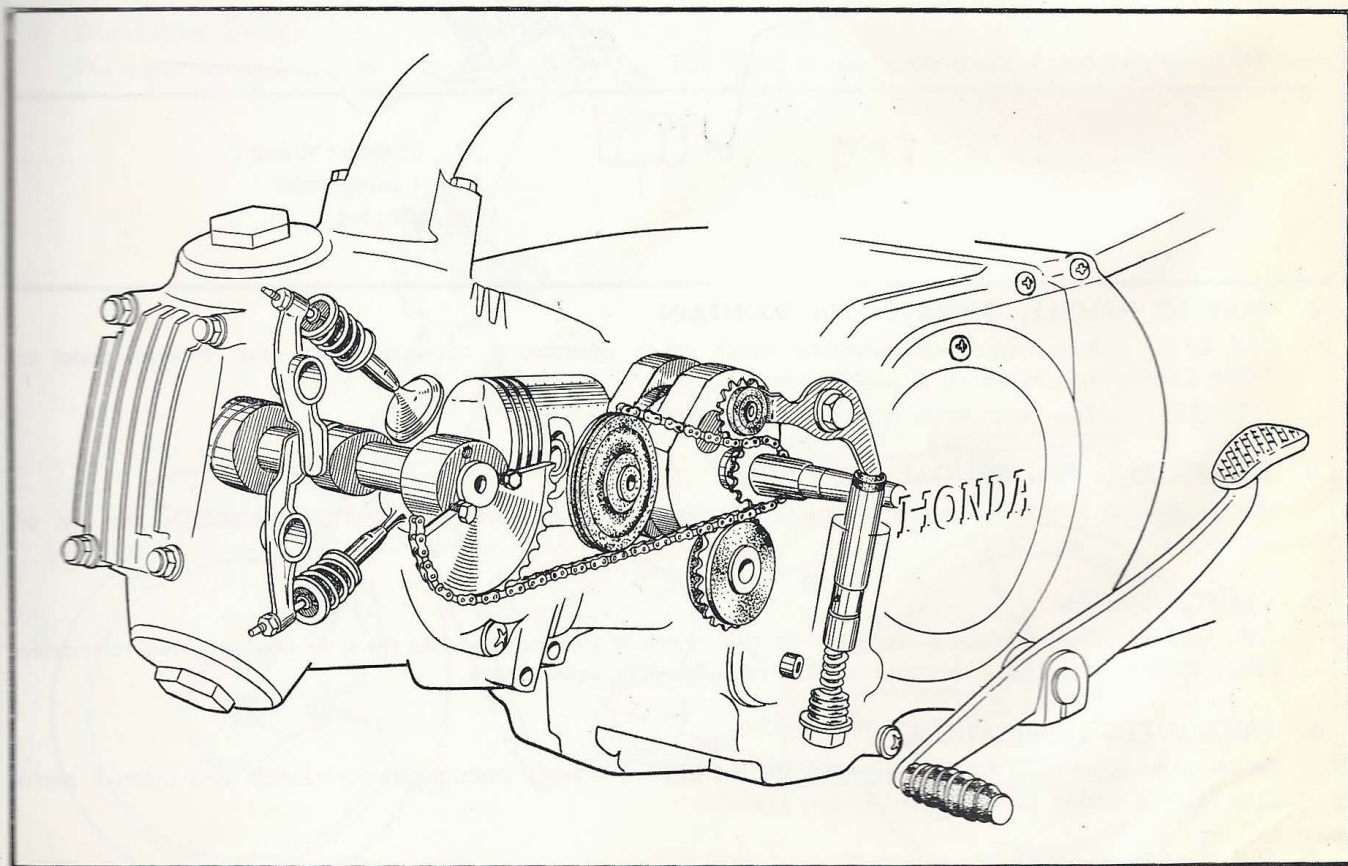

2. SELF ADJUSTING CAM CHAIN TENSION

An oil damping system is employed to absorb the chain vibration and which also provides quiet operation even at high speed.

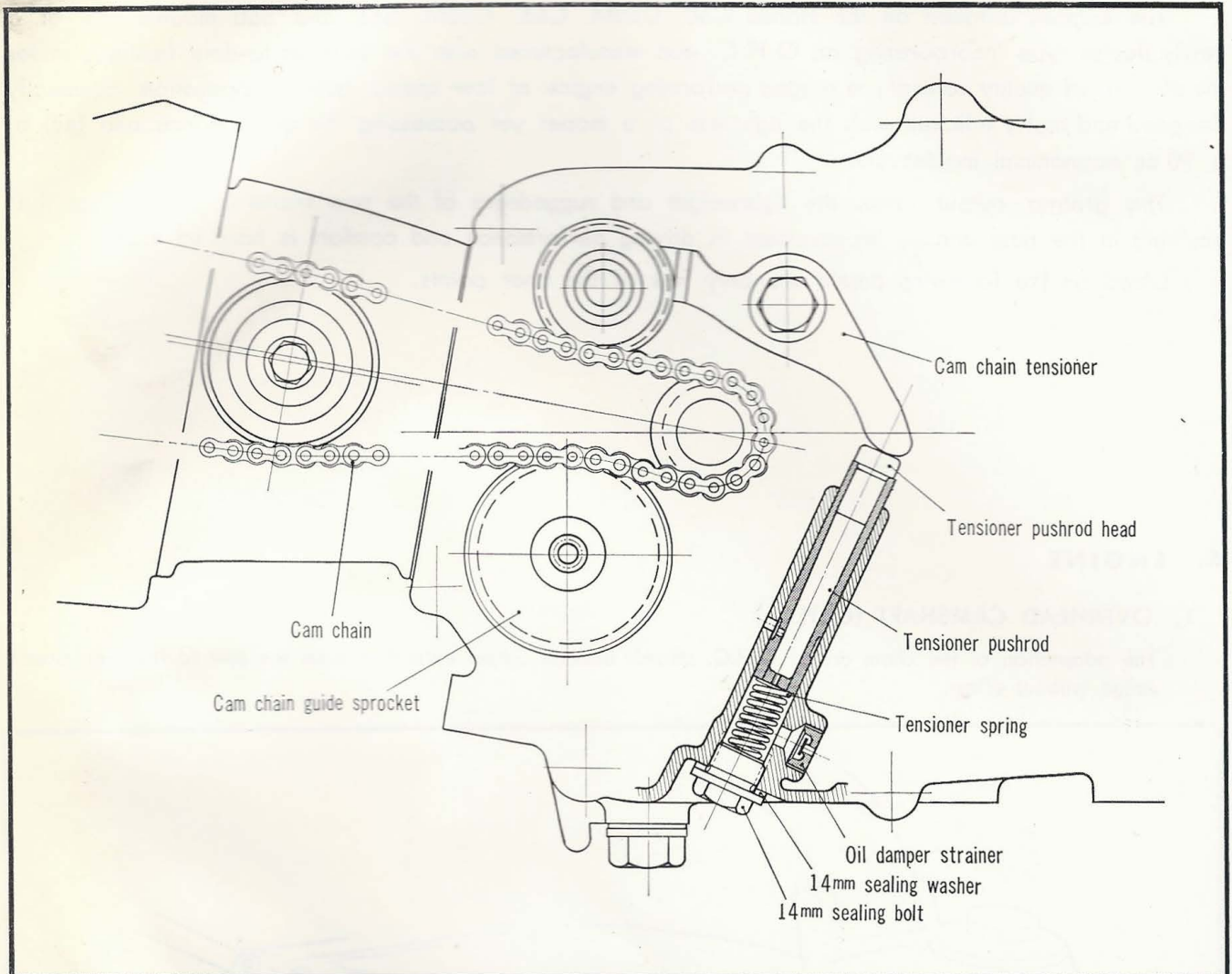

3. EASY TO HANDLE, OPERATE AND MAINTAIN

C50, C65, Incorporates an automatic clutch which operates in conjunction with the change pedal to C50M, C65M: simplify handling.

S50, S65: The clutch lever action is made exceedingly light.

4. SCREEN AND CENTRIFUGAL OIL FILTERS

The engine oil is doubly filtered to practically eliminate engine parts wear and greatly prolong the life of the engine.

5. CLUTCH SYSTEM

C50, C65, The centrifugal multiple wet disc clutch is incorporated into the gear change system to provide C50M, C65M: easy gear changing as well as to simplify maintenance.

6. PRESSURIZED LUBRICATION

An oil pump is installed to pressure lubricate the primary moving components (crankshaft and related parts) to give them added durability and longer life.

7. Full Complement of Electrical Equipment

Complete and distinct safety items such as the headlight, taillight, turn signal lamp and horn provide assurance to safe driving.

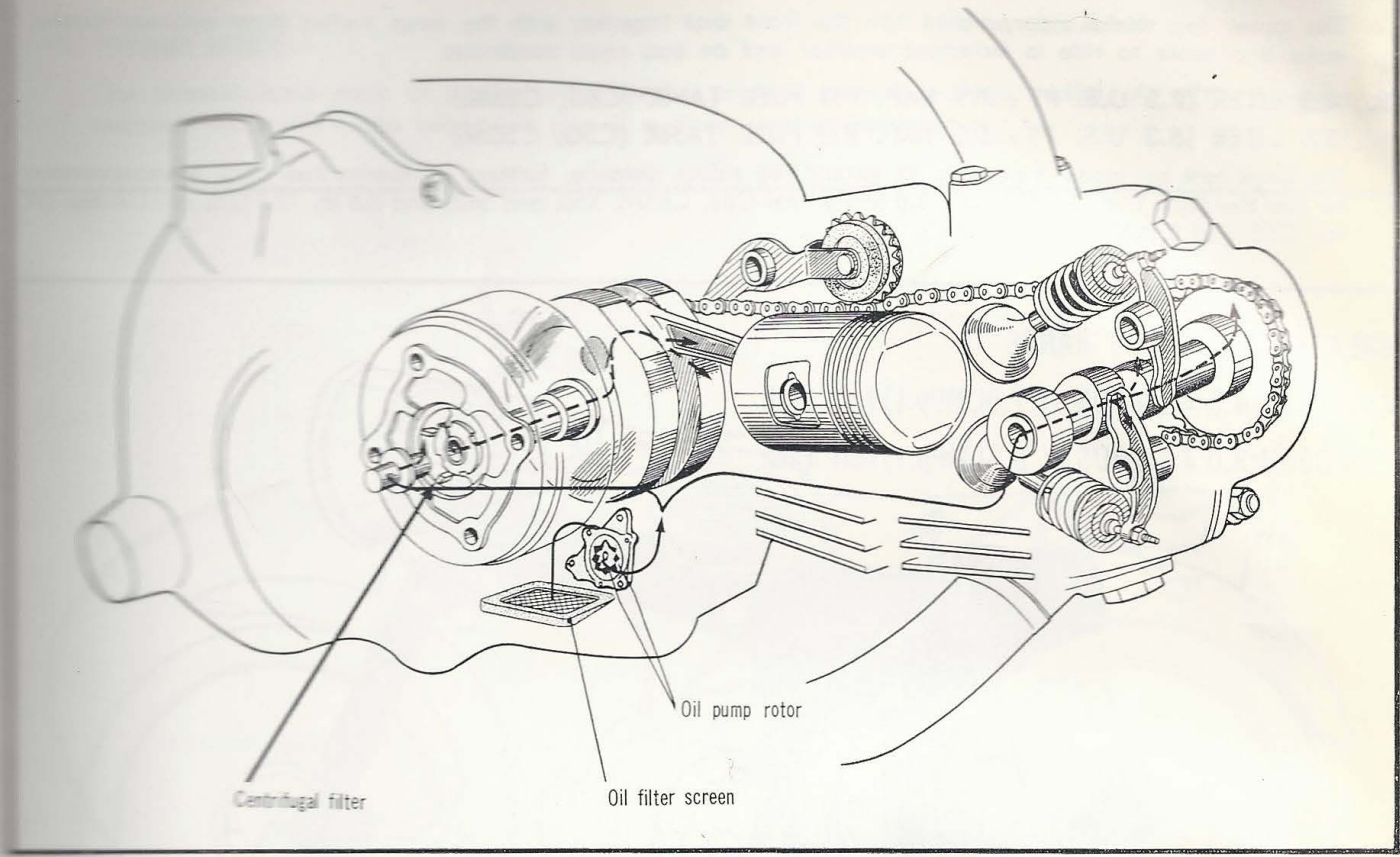

B. FRAME (C50, C50M, C65, C65M)

1. Distinctive Design

The advanced styling is an original Honda, unique, not found in any motorcycles or scooters the world over.

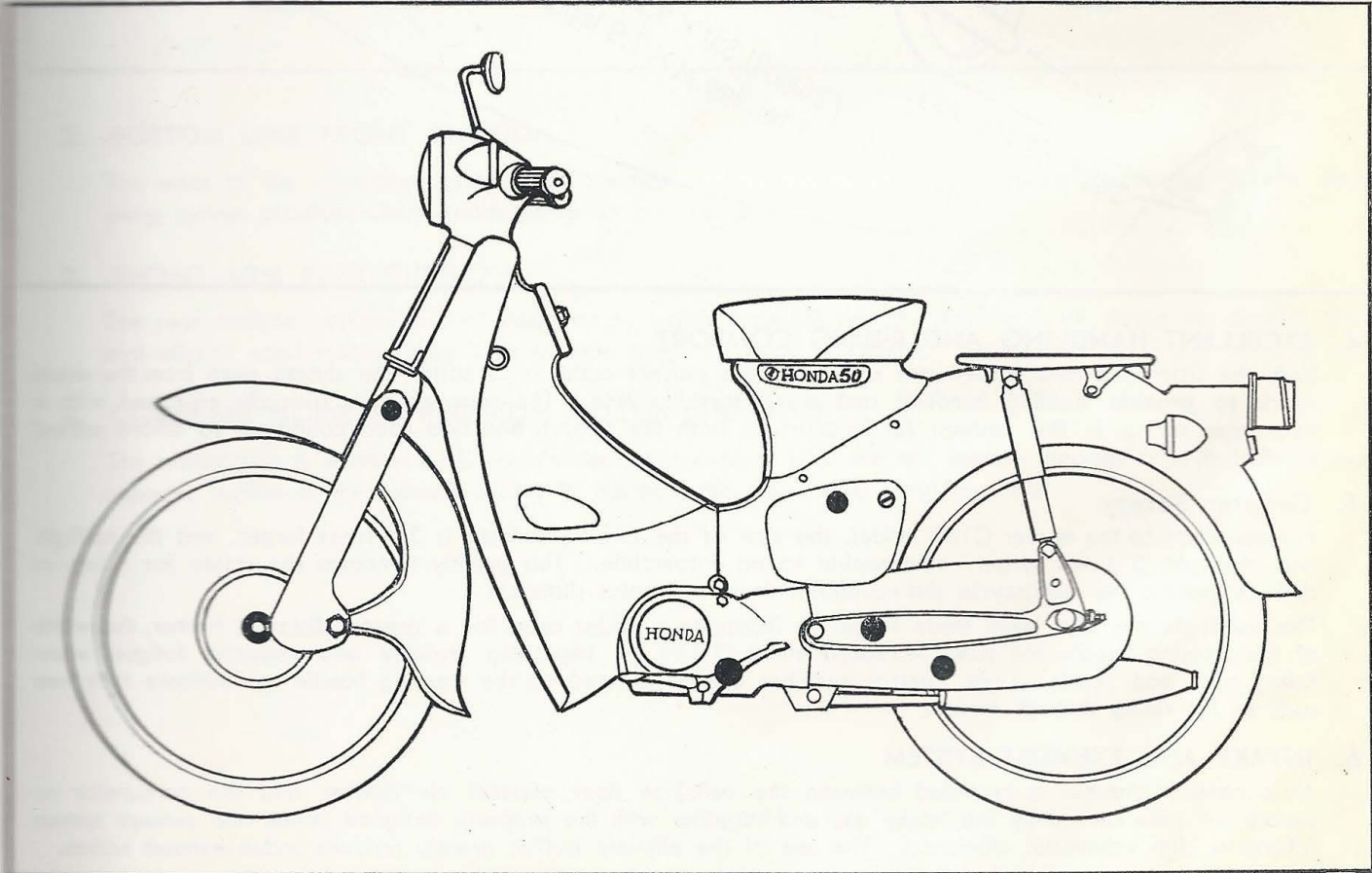

2. EASY HANDLING

The cover (leg shield) incorporated into the front strut together with the deep welled front and rear fenders make it possible to ride in inclement weather and on bad road conditions.

3. 4.5 LITER (9.5 U.S. PT : 7.9 IMP. PT) FUEL TANK (C65, C65M)

3.0 LITER (6.3 U.S. PT : 5.3 IMP. PT) FUEL TANK (C50, C50M)

The large tank has made it possible to extend the riding distance, further, a reserve fuel cock is incorporated to use the final 1 lit. (2.1 U.S. pt : 1.8 Imp pt) for C65, C65M, S50, and S65, and 0.8 lit. (1.7 U.S. pt : 1.4 Imp. pt) for C50 and C50M.

GREATER TRAVELING RANGE

C65, C65M: 4.5 l (9.5 US.pt, 7.9 LMPp.t) full tank
 C50, C50M: 3.0 l (6.3 US.pt, 5.3 LMPp.t) full tank

380Km (236miles)

C65, C65M: (25mi/U.Spt × 9.5U.Spt + 42miles fuel reserve)
 (30mi/Imp.pt × 7.9 Imp.pt + 42miles fuel reserve)

The illustration shows a person riding a motorcycle on a road that curves into the distance. A character representing a fuel gauge is shown with a happy face and arms raised, positioned above the road. A map of India is shown in the bottom left corner, with a line indicating the distance of 380 Km (236 miles). The text provides fuel tank capacities and range calculations for the C65, C65M, and C50, C50M models, including a 42-mile fuel reserve for each.

4. EXCELLENT HANDLING AND RIDING COMFORT

Both the front and rear wheels are equipped with perfect cushions to soften the shocks even from the worst roads to provide stable handling and a comfortable ride. The rear wheel is specially equipped with a two-stage spring in the cushion to function on both the smooth and bad road conditions to afford added comfort over a broader range.

5. Greater Safety

In comparison to the earlier C100 model, the size of the turn signal lamp is 3.5 times larger, and the taillight and stoplight 3 times larger, comparable to an automobile. This greatly increases the safety for riding at dusk by making the motorcycle distinguishable from a greater distance.

The headlight has also been made larger to illuminate a wider area for a greater distance, further, the width of the steering handle has been increased 60mm (2.4 in) for improving stability and reducing fatigue when riding over bad roads. Light control switches are all located on the steering handle to facilitate their use such as for riding through tunnels.

6. INTAKE AND EXHAUST SYSTEM

An expansion chamber is provided between the cellulose fiber element air cleaner and the carburetor to isolate the noise caused by the intake air, and together with the properly designed intake and exhaust system affords a high volumetric efficiency. The use of the efficient muffler greatly reduces undue exhaust noises.

C. FRAME (S50, S65)**1. FRAME BODY**

The stressed frame made of pressed sheet steel is used to maintain uniform quality. All of the equipment are enclosed within the frame interior to give it a clean exterior appearance.

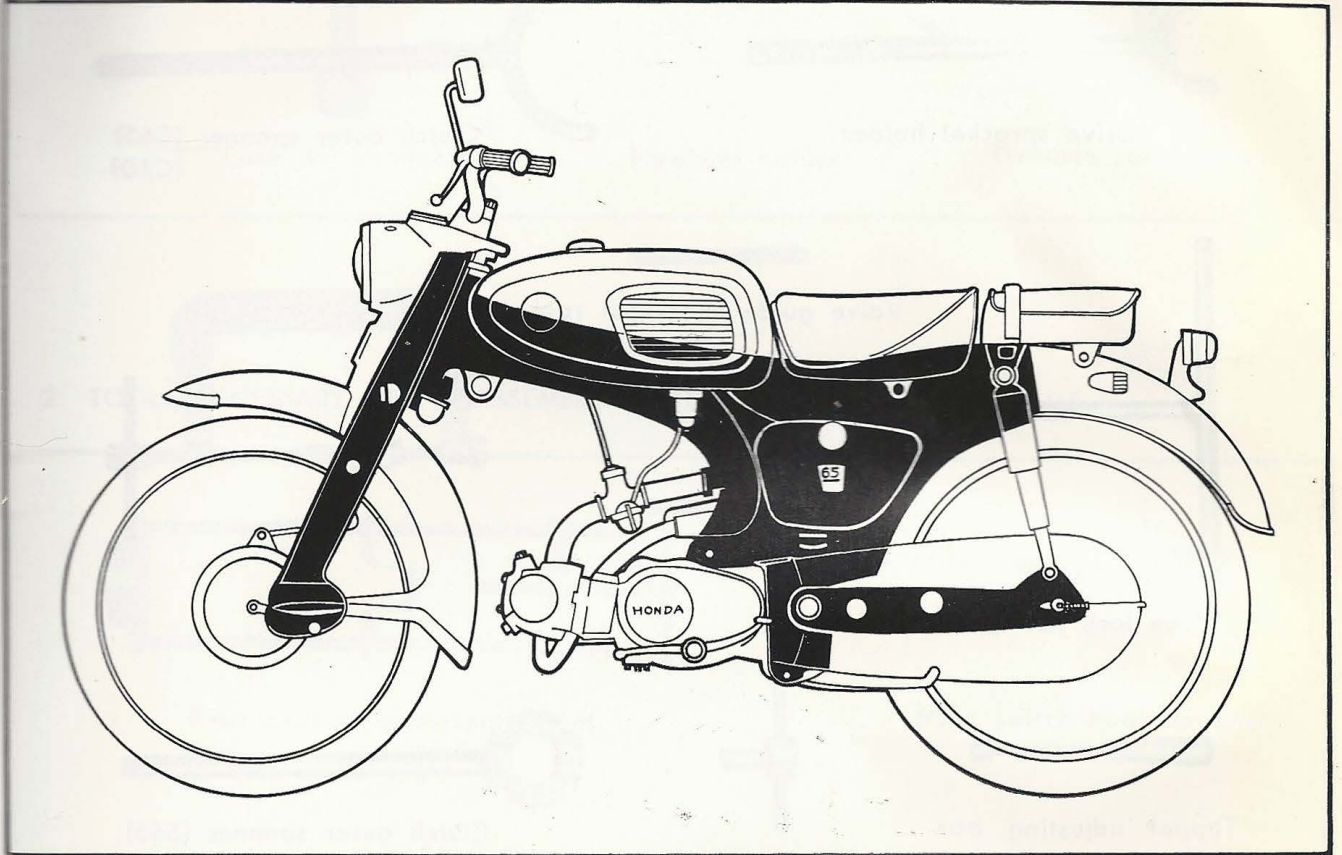
**2. BOTTOM LINK FRONT CUSHION**

The wear to the respective components are lessened by this design. The smooth functioning of the dampening system provides comfortable riding on bad roads.

3. SWING ARM REAR CUSHION

The rear cushion employs a dual stage spring which functions equally well for both single or double riders and affords comfortable riding over a wide range of road conditions.

4. COMPLETE NOISE SUPPRESSION SYSTEM (S50, S65)

The motorcycle is equipped with a silencer incorporated into the air cleaner in addition to an adequate capacity muffler in the exhaust system to maintain the noise at a very low level.

2. SPECIAL TOOLS

1. TOOLS NECESSARY FOR DISASSEMBLY AND REASSEMBLY OF THE ENGINE



Drive sprocket holder

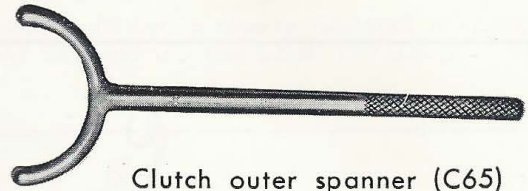

Clutch outer spanner (C65)
(C50)

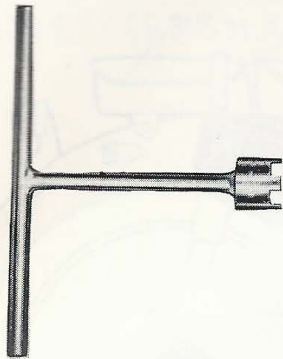

16mm lock nut spanner



Valve guide knock-out tool



Valve guide installing tool

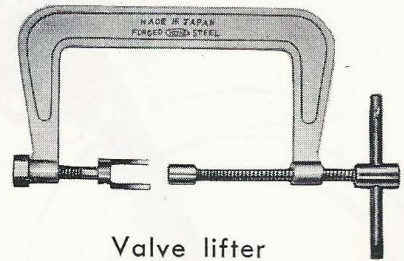

Valve lifter



Tappet adjusting box



Tappet locking box



Clutch outer spanner (S65)

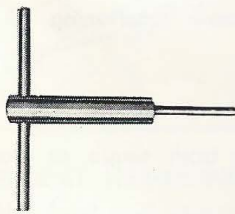

Cutter holder



Valve seat cutters



Valve guide reamer

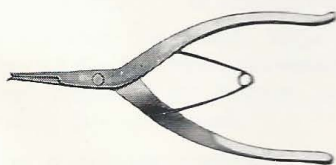

Snap ring pliers

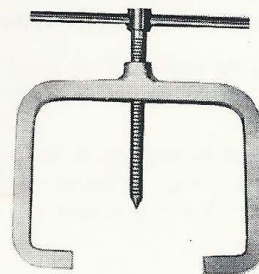

Clutch assembly tool

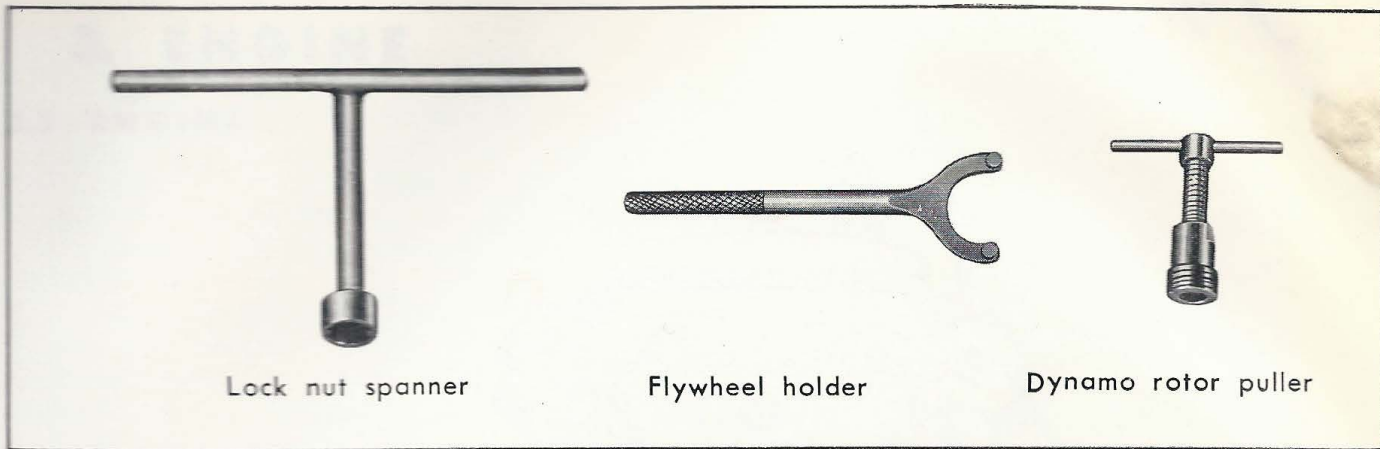

2. TOOLS NECESSARY FOR DISASSEMBLY AND REASSEMBLY OF THE FRAME

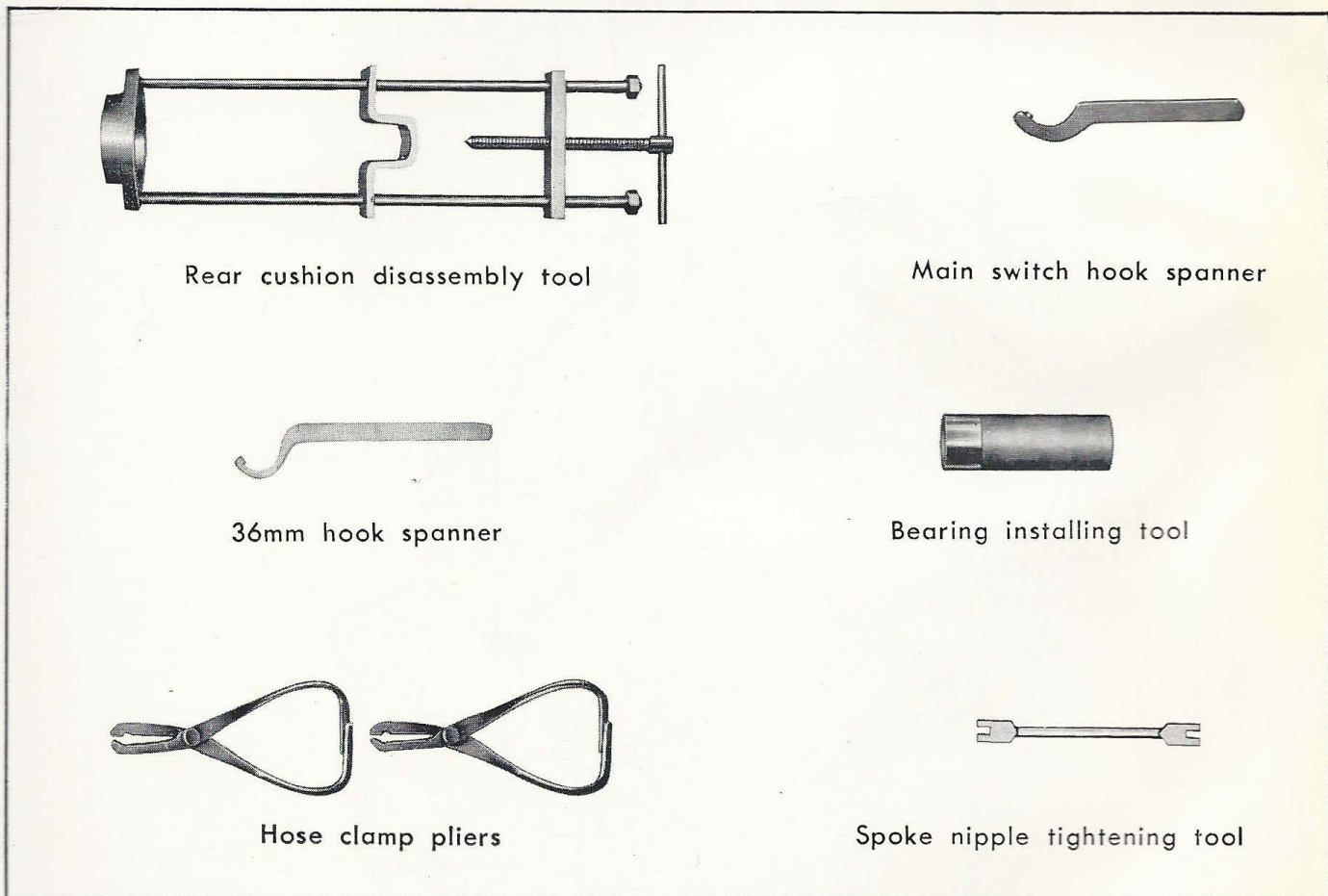

3. ENGINE

3.1 ENGINE

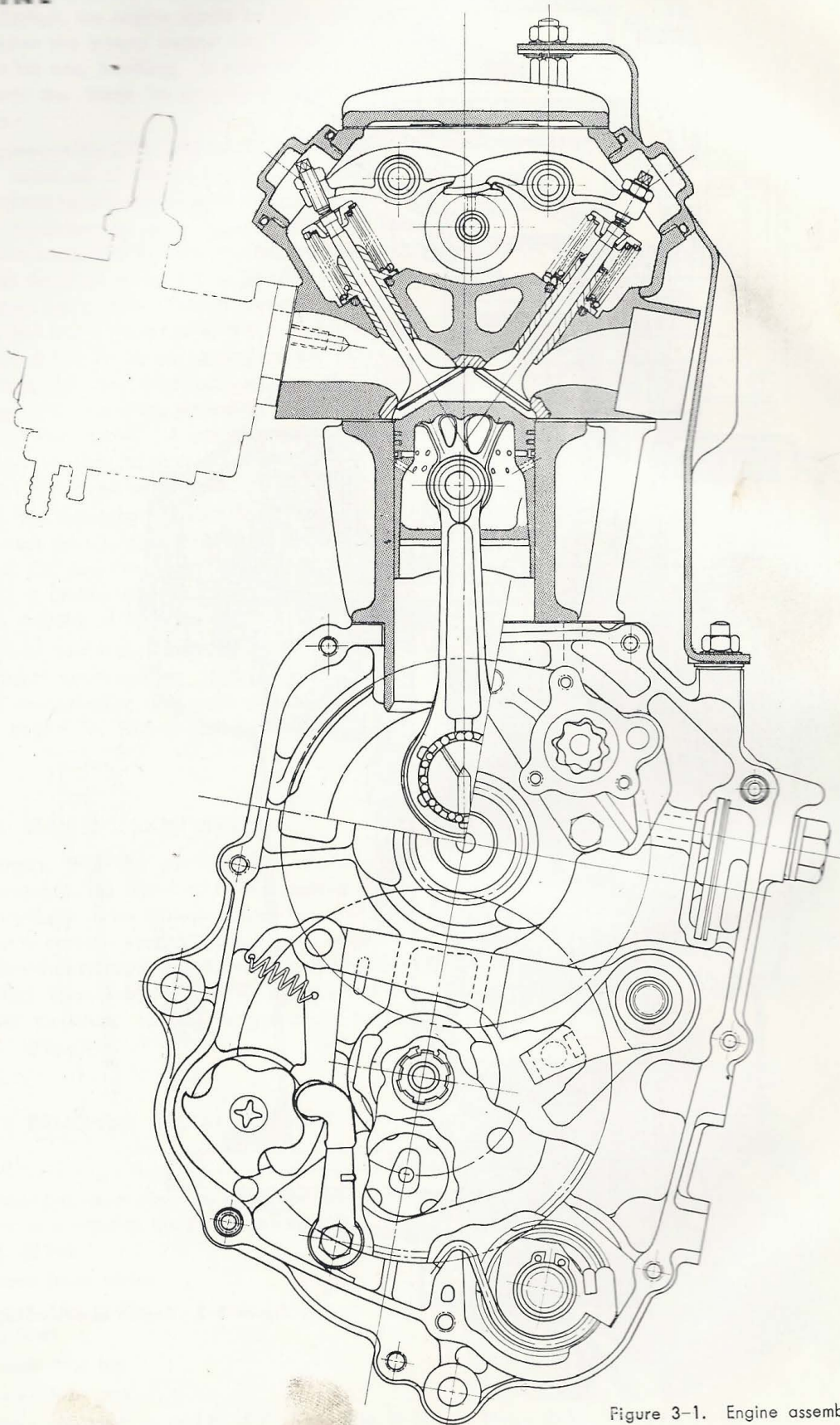

Figure 3-1. Engine assembly diagram (1)

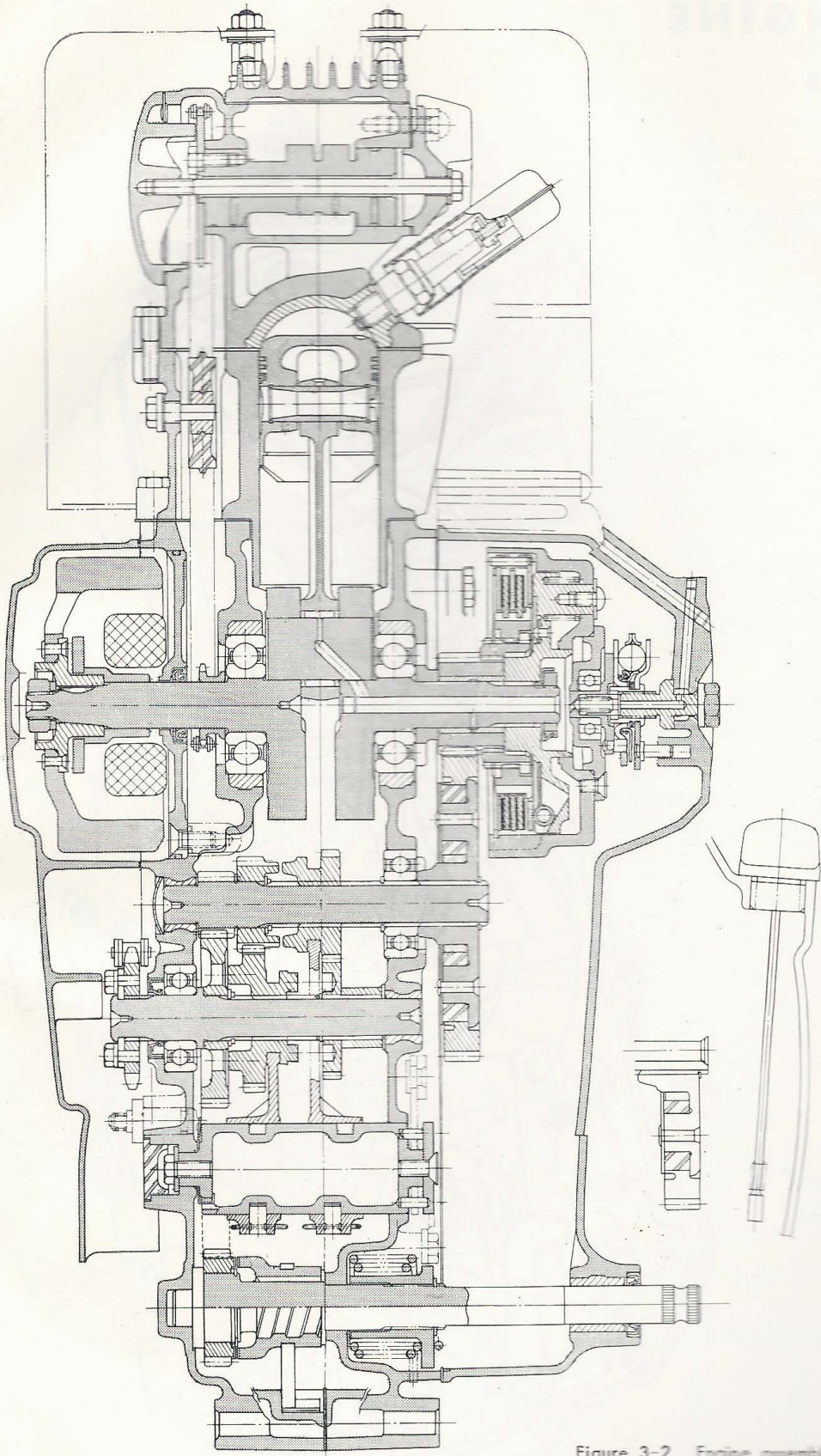

Figure 3-2. Engine assembly diagram (2)

1. ENGINE DESCRIPTION

The main factors which have a large effect on the performance of the engine are the design of the cylinder head, materials, and the manufacturing tolerances. Further, the engine should be light in weight, sturdy, greater the power output the better, and a requirement for easy handling. In addition the engine should match the frame to provide a clean overall appearance.

The engines on the C50, C50M, C65, C65M, S65 and S50 have taken all of the above consideration into account and had been designed after extensive research had been expended to meet these conditions. The O.H.C. system which affords the most advantageous valve location has been incorporated to provide for a high heat efficiency combustion chamber design. The light weight endless chain enclosed in the left side of the engine is used for the direct driving of the O.H.C.; a damper type cam chain tensioner prevents the chain from whipping or vibrating, providing a quiet engine operation at high speed. A compact and a rugged engine which is easy to maintain and having a high performance has been developed.

Further, the crankshaft is built to withstand heavy load and high speed; the transmission shaft bearing design, and the dual centrifugal and screen filters give the engine durability and provide extended service as well as stability at high speed.

In contrast to the push rod engine, the new engine has far fewer reciprocating parts, to eliminate the source of engine noise and make possible a smooth operating engine for high speed and greater output.

2. POWER TRANSMISSION SYSTEM

The energy from the combustion of the fuel mixture is transmitted to the piston → connecting rod → crankshaft → clutch (drive plates) → clutch outer → friction disc → clutch center → primary drive gear → primary driven gear → transmission main shaft → main shaft gear → counter shaft gear → counter shaft → drive sprocket → chain → to the rear wheel, progressively in that sequence. (Fig. 3-3)

3. ENGINE REMOVAL INSTALLATION

a. Removal

- (1) Loosen the 6mm cap nuts from the air cleaner cover and remove the air cleaner. (C50, C50M, C65, C65M)
- (2) Remove front cover
- (3) Remove the muffler (Fig. 3-4)
- (4) Remove step bar
- (5) Remove tool box
- (6) Remove oil pipes A and B. (S50, S65) (Fig. 3-5)

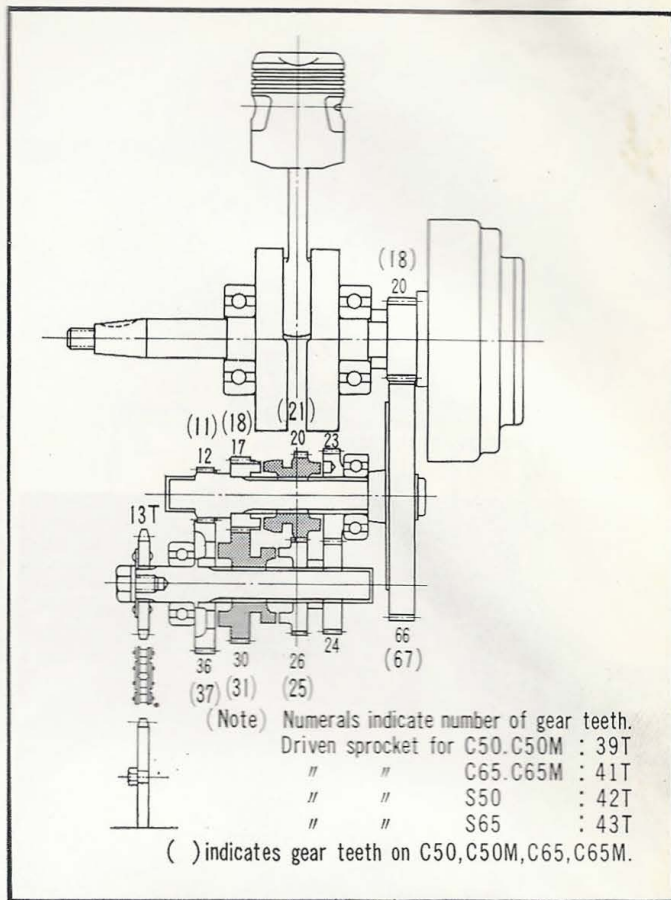

Figure 3-3. Power transmission diagram

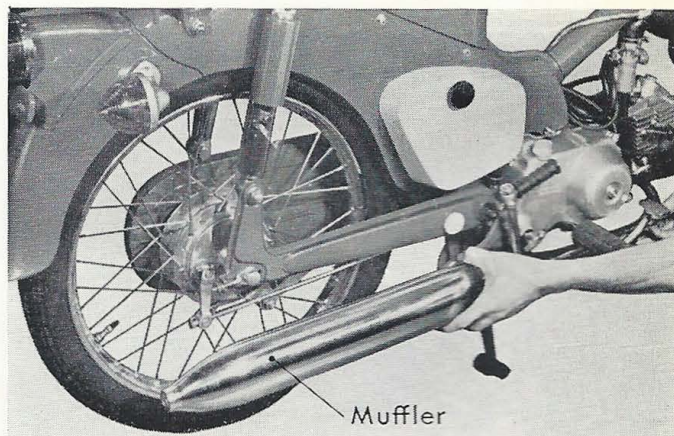

Figure 3-4. Removing muffler

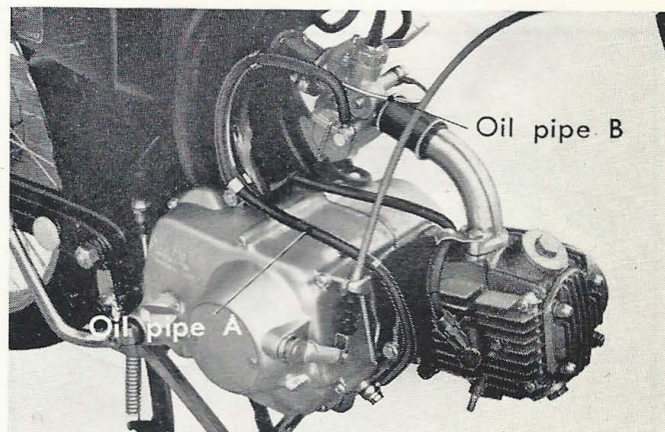

Figure 3-5. Removing oil pipes

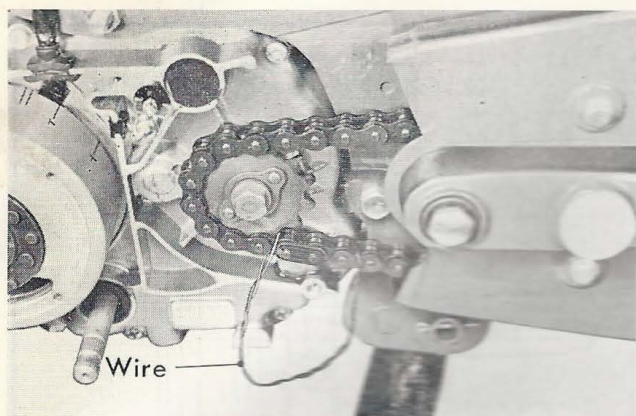

Figure 3-6. Removing the drive chain

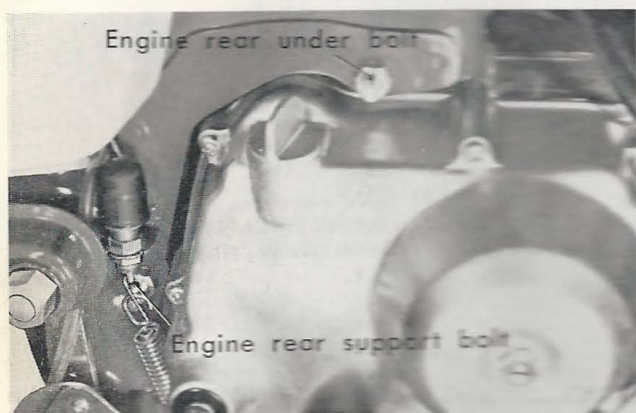

Figure 3-7. Engine mounting bolt



Figure 3-8. Temporary installation

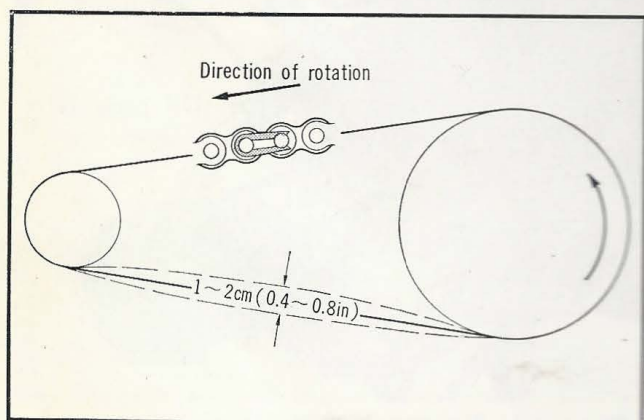

Figure 3-9. Installing direction of joint link

- (7) Remove the two 6mm nut installing the carburetor and separate the carburetor from the cylinder head. (C50, C50M, C65, C65M)
For S50 and S65, separate the inlet pipe and cylinder head.

(Note) When it is necessary to remove the carburetor on the C50, C50M, C65 and C65M, pinch the fuel pipe with a hose clip to prevent leaks. This is necessary since the fuel cock is installed on the carburetor.

- (8) Disconnect the clutch cable (S50, S65)
- (9) Remove kick arm and gear change pedal
- (10) Remove the left crankcase cover and the electrical leads.
- (11) Rotate the rear wheel to position the chain joint as shown in Fig. 3-6 and disconnect the drive chain.

When removing the chain joint, the task can be facilitated and the chain prevented from coiling in the chain case by attaching wires to both joining ends of the chain.

- (12) Disconnect the high tension terminal from the spark plug.
- (13) Remove the high tension cord clip installed on the right crankcase cover.
- (14) Remove the brake pedal spring, stop lamp spring, the two 8mm engine mount bolt nuts and pull out the two engine support bolts; the engine can then be detached from the frame. (Fig. 3-7)

b. Installation

- (1) Perform the engine installation by reversing the engine removal procedure in section 3.14a.
- (2) The engine installation can be facilitated by using the ⊕ T-handle screwdriver to temporarily set the engine and then installing the engine support bolts. (Fig. 3-8)
- (3) The brake pedal spring and the stop spring switch is mounted together with the engine rear under bolt.
- (4) When connecting the drive chain, make sure that the joint clip is installed with the opening opposite to the direction of the chain movement. (Fig. 3-9)

Adjust the chain tension after installation to 1~2cm (.40~.80 in).

4. LUBRICATION SYSTEM

The oil from the crankcase after being drawn into the oil strainer is diverted for lubrication into the following two routes.

- (1) Right crankcase → passageway in the right crankcase cover → centrifugal filter → to lubricate the crankshaft and associated parts.
- (2) Right crankcase (upper part of the oil pump) → through the cylinder stud bolt (right lower side) → into the rocker arm side cover → sprayed from the four oil holes in the camshaft → to lubricate the respective sections of the cylinder head → into the oil return hole at the lower end of the exhaust valve and returns to the crankcase. The oil that passes through the camshaft lubricates the cam chain and returns to the crankcase. In this way, the lubrication of the engine is performed by the two oil routes and the oil spray in the crankcase. (Fig. 3-10)

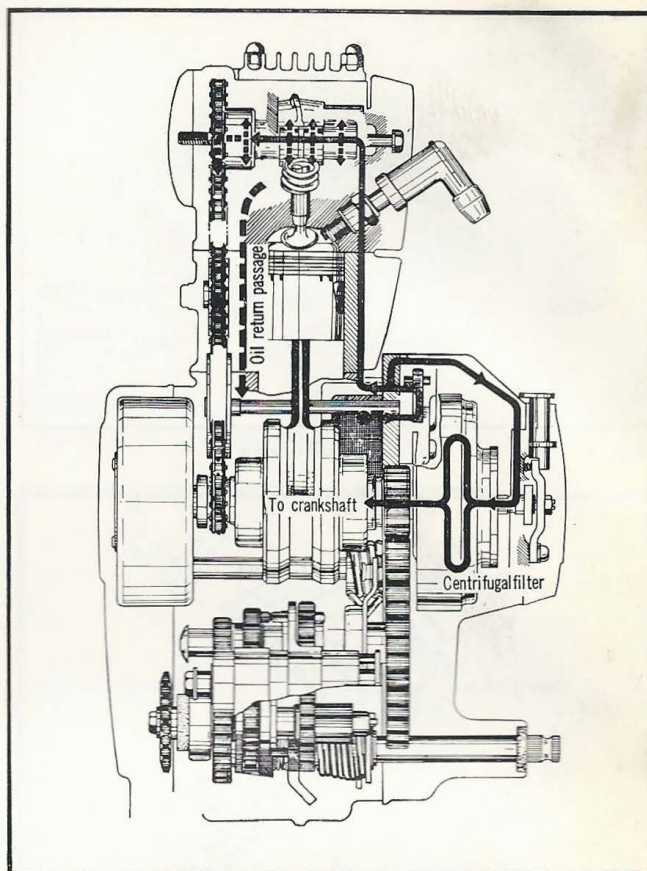

Figure 3-10. Pressure lubrication diagram

5. OIL PUMP PRINCIPLE

In the past, gear type oil pump using two gears were used, however, on these models a more efficient and compact trochoid oil pump is used. This pump consists of an inner and an outer rotor. The pumping action is produced by the differences in the shape and number of the teeth between the inner and the outer rotors. (Fig. 3-11)

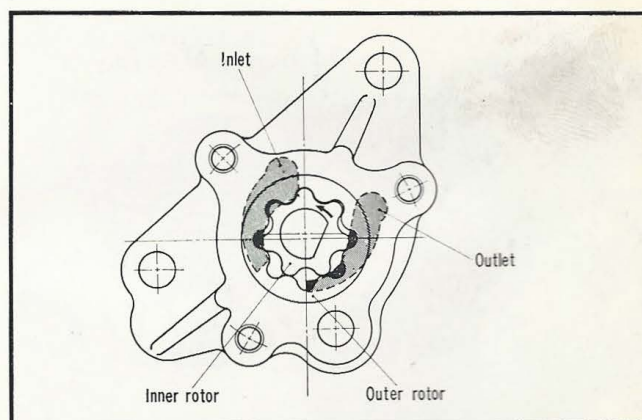

Figure 3-11. Oil pump theory of operation

a. Disassembly

- (1) Remove the clutch assembly as described in section 3.14a.
- (2) Remove the three 6mm bolts and remove the oil pump as a unit. (Fig. 3-12)

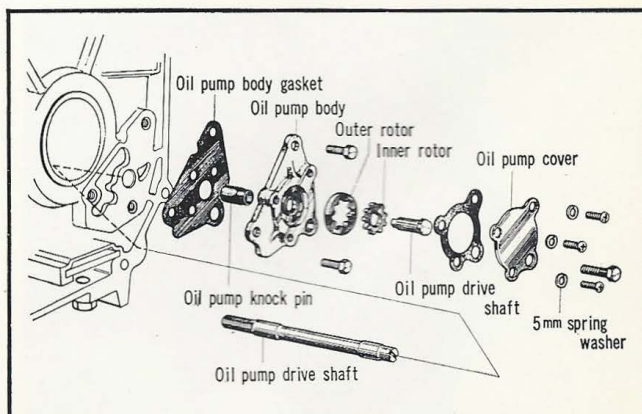

Figure 3-12. Disassembling the oil pump

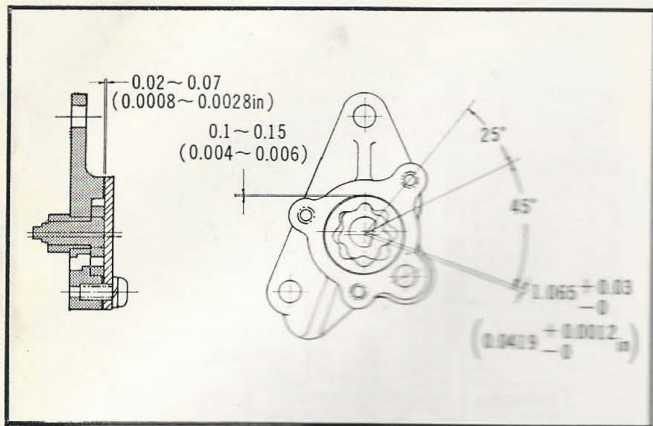

Figure 3-13. Oil pump gear clearance

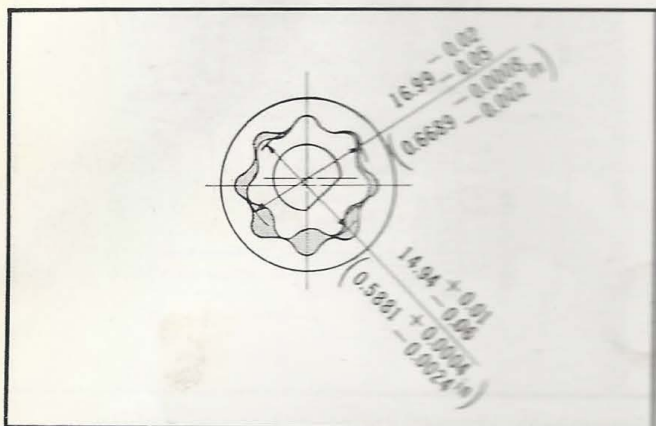

Figure 3-14. Oil pump backlash

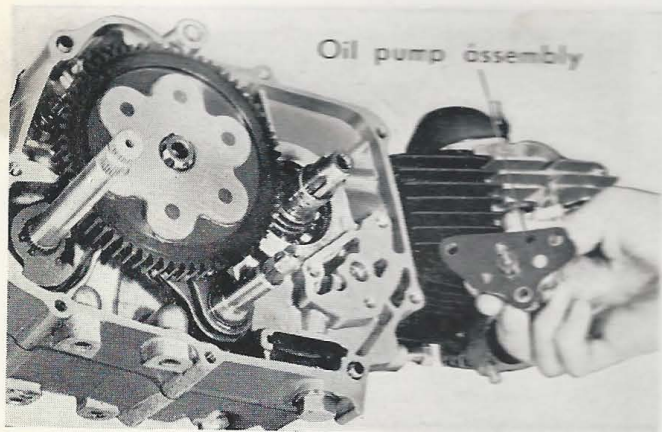

Figure 3-15. Installing the oil pump unit

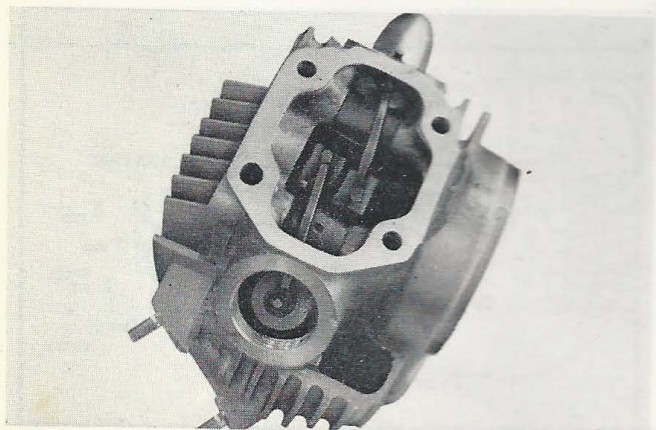

Figure 3-16. Cylinder head assembly

b. Inspection

- (1) Oil pump outer rotor to housing clearance (Fig. 3-13)
Standard value 0.1~0.15 (0.004~0.006 in)
- (2) Rotor to rotor clearance
Standard value 0.02~0.07 (0.008~0.028 in)
- (3) Rotor tip clearance (Fig. 3-14)
Standard value 0.15 max. (0.006 in)
Serviceable limit → replace if over 0.2 (0.008 in)

c. Reassembly

- (1) Fit the inner rotor to the outer rotor and then install the pump assembly to the right crankcase. Install the oil pump assembly to the right crankcase. (Fig. 3-14)
- (2) Install the clutch assembly and the right crankcase cover.

3.2 CYLINDER HEAD

1. CYLINDER HEAD DESIGN

The cylinder head is constructed of an aluminum alloy casting incorporating combustion chamber, inlet port, exhaust port, and carries the camshaft, valves, valve rocker arms.

The camshaft is driven by the timing sprocket through a chain on the right side of the engine.

The combustion chamber is made semi-spherical for increased cooling and better combustion efficiency, and also incorporating a squish area. (Fig. 3-17)

(Squish area)

This is an area provided between the piston and the cylinder head to further compress part of the fuel air mixture at the end of the combustion stroke to create a turbulence within the main fuel mixture. As the swirling fuel mixture is diverted toward the spark plug the flame propagation is accelerated, allowing the leaner than normal fuel air ratio or the slower burning fuel mixture to burn smoothly, further, decreasing the tendency for knocking. (Fig. 3-18)

Because the use of the O.H.C. have decreased the reciprocal operating load of the valve mechanism, high engine speed and good stability at high output have been made possible. In addition, the increased combustion efficiency has been achieved due to unrestricted location of the valves and the positioning of the spark plug at the center of the combustion chamber. A better flow of the cooling air over the top of the cylinder head is afforded and this in conjunction with the aluminum head has increase the cooling efficiency to a considerable degree.

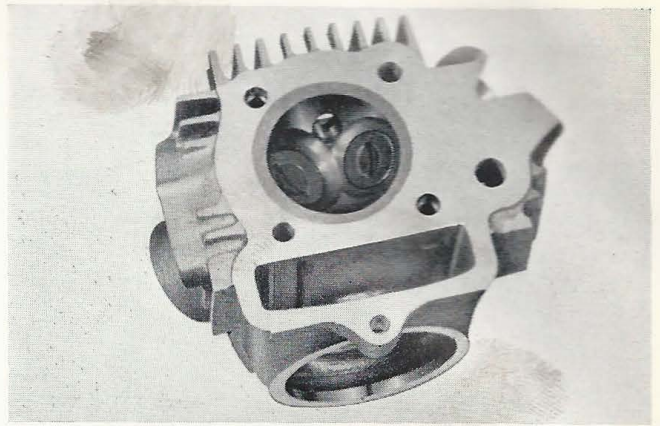

Figure 3-17. Cylinder head combustion chamber

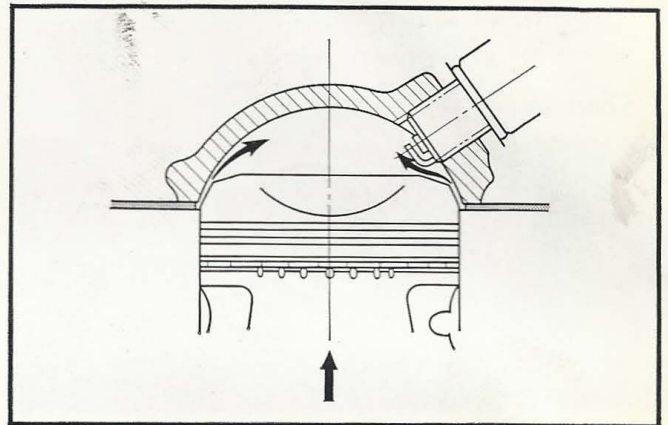

Figure 3-18. Squish area

a. Disassembly

- (1) Drain the oil
- (2) Remove the flywheel and stator assemblies.
- (3) Remove the 6mm hex and cap nuts holding the cylinder head cover and then remove the cover.
- (4) Rotate the crankshaft so that the piston is at top dead center, by aligning the woodruff key on the crankshaft and the "O" mark on the sprocket in line with the cylinder axis and then remove the three 5mm hex bolts. (Fig. 3-19)
- (5) The right and left cylinder head side cover can be separated by removing the 6mm hex bolt. (Fig. 3-20)
- (6) Remove the cylinder head.

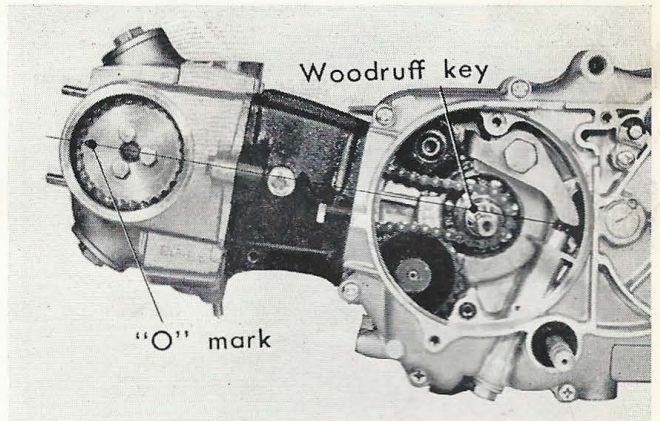

Figure 3-19. Removing cam sprocket

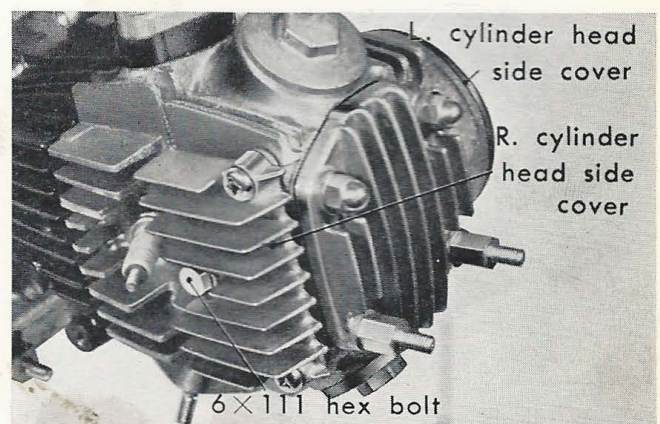

Figure 3-20. Removing R & L cylinder head cover

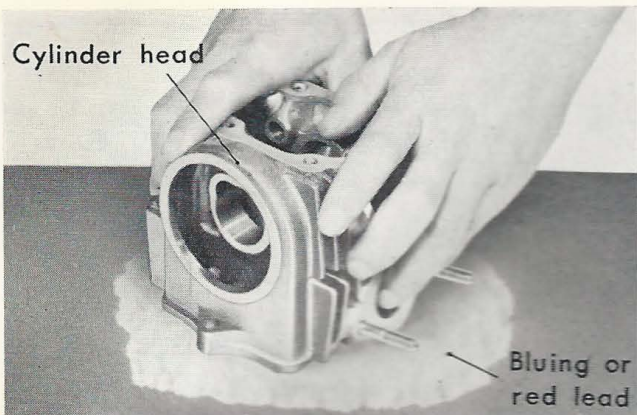

Figure 3-21. Checking cylinder head warpage

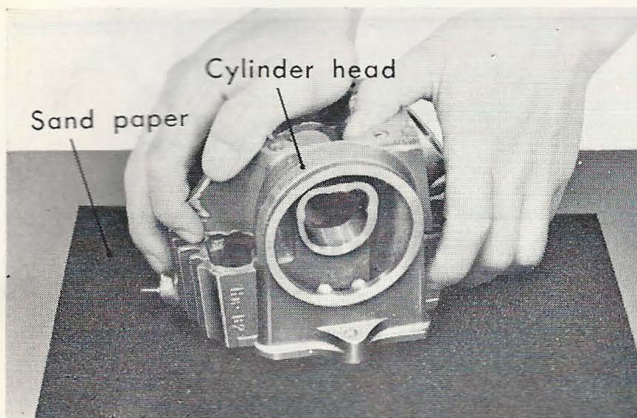

Figure 3-22. Repairing warped cylinder head

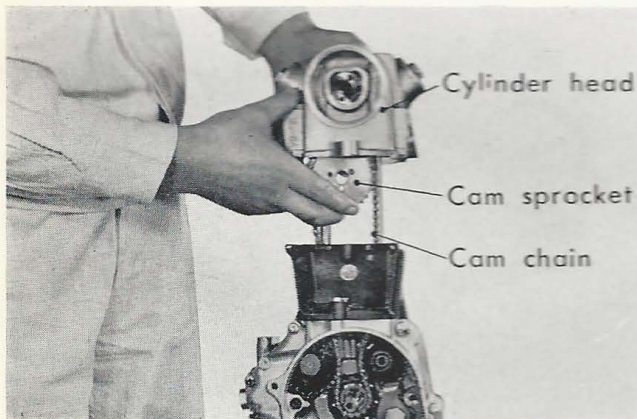

Figure 3-23. Installing the cylinder head

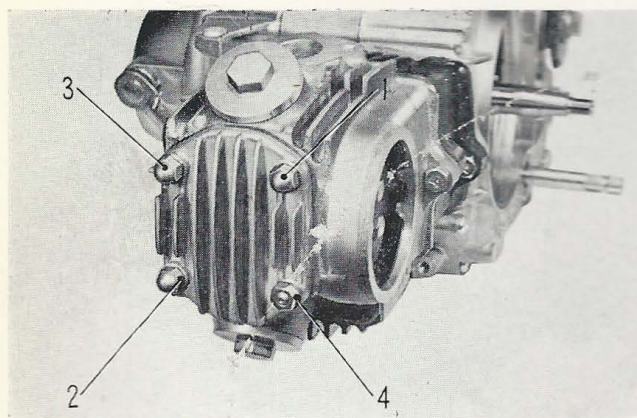

Figure 3-24. Torquing sequence of cylinder head

b. Inspection and repair

The cylinder head is exposed to the high pressure and temperature resulting from the combustion of the fuel mixture; further, when the head is unevenly torqued, it may develop cracks or warpage and will be the cause of defective sealing between the head and the cylinder and result in gas leak, air sucking and drop in compression.

The warpage of the cylinder head does not develop suddenly and it may be overlooked, therefore, caution should be exercised during reassembly, since the uneven torquing of the cylinder head is a very common fault.

To inspect for warpage of the cylinder head, apply a thin coat of bluing or red lead on a surface plate and work the mating surface of the cylinder head on the surface plate; the warpage can be determined by the transfer of the bluing on to the cylinder head. (Fig. 3-21)

To correct the warpage, lap the cylinder head on the surface plate with a #200 sandpaper, finally finish by using a #400 sandpaper and then inspect again with the bluing. (Fig. 3-22)

- (1) Cylinder head combustion chamber [] for C50, C50M, S50

	Standard value	
Height	15.66 ± 0.05 (0.620 ± 0.002 in.)	14.00 ± 0.05 (0.552 ± 0.002 in.)
Capacity (Spark plug installed)	13.1 ± 0.2 cc ($1.7994 \pm .0122$ cu in.)	9.5 ± 0.2 cc (0.374 ± 0.002 in.)

- (2) Cylinder head gasket thickness.
Standard value $\rightarrow 1.0 \sim 1.1$ (0.039 \sim 0.043 in)
Serviceable limit \rightarrow Replace if under 0.8 (0.032 in)
- (3) Cylinder head torque
 $90 \sim 120$ kg-cm (6.5 \sim 9.0 ft/lbs)

c. Reassembly

- (1) Install cylinder head together with cam sprocket. (Fig. 3-23)

(Caution)

- When installing the cylinder head, do not forget to install the "O" rings and dowel pins.
- (2) When torquing the cylinder head, tighten the nuts in the diagonal sequence to prevent pressure leaks. Refer to Fig. 3.24 for torquing procedure. (Fig. 3-24)
- (3) In the same procedure as in the disassembly, position the woodruff keyway in the crankshaft, and the "O" mark on the cam sprocket in line with the piston and install.
- (4) Assemble the right and left cylinder head side cover.

2. VALVE SEAT CONTACT SURFACE

Apply a thin coating of bluing or red lead evenly on the entire surface of the valve face, hold the valve firmly against the valve seat while rotating the valve. Inspect the valve seat for a uniform and a continuous width of bluing.

Standard value → 1 ~ 1.3 (0.040 ~ 0.051 in)

Serviceable limit →

The valve seat is recut with three types of cutter; 60°, 45°, and 30° cutters.

The location and the width of the valve seat contact area is accomplished with the 60° and the 30° cutters while the 45° cutter is used for the facing of the valve contact area. (Fig. 3-25, 3-26)

Finally, the valve lapping operation is performed. Place a liberal amount of lapping compound on the valve face and lap the valves, applying a slight pressure while rotating to the right and left, using a suction cup lapping tool. Wash off the compound thoroughly and inspect the seating with the bluing.

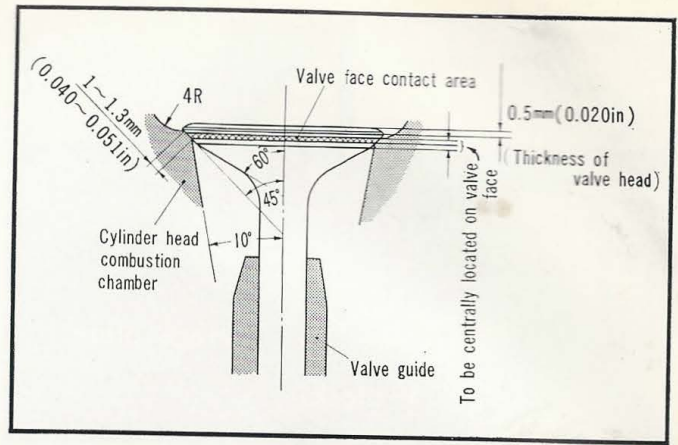

Figure 3-25. Valve seat contact area

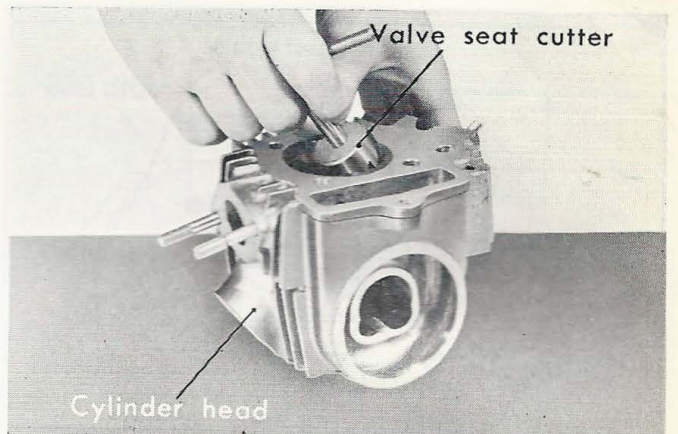

Figure 3-26. Reworking valve seat

3. INSPECTION OF VALVE CONTACT AREA

Assemble the valve into the cylinder head as shown in Fig. 3.27 so that the valves are well seated and fill the cylinder head combustion chamber with oil, inject a blast of air in from the inlet and exhaust ports and if any bubbles should appear, it is an indication that the valve seats are not completely sealed. (Fig. 3-27)

(1) Inlet and Exhaust Valve Guide. (Fig. 3-28, 3-29)

	Standard Value	Serviceable Limit
Outside dia	10 mm (0.394)	
	+0.065 (0.003 in.)	
	+0.055 (0.002 in.)	
Interference fit	0.040-0.065	
	(0.002 ~ 0.0026 in.)	
Inside dia	5.5 mm (0.217)	Replace if over 5.53 mm (0.199 in.)
	-0.015 (0.0006 in.)	
	-0.025 (0.0010 in.)	

(2) Exhaust Valve, [] values are for C50, C50M, S50

	Standard Value	Serviceable Limit
Total length	63.9 (2.483 in.)	Replace if under 63.5 (2.502 in.) [64.9] (2.557 in.)
	[65.3] (2.573 in.)	
Stem dia	5.5 mm (0.217 in.)	Replace if under 5.4 mm (0.213 in.)
	-0.055 (0.0022 in.)	
	-0.065 (0.0026 in.)	
Head thickness	0.7 (0.026 in.)	Replace if under 0.4 (0.016 in.)
	±0.1 (0.004 in.)	

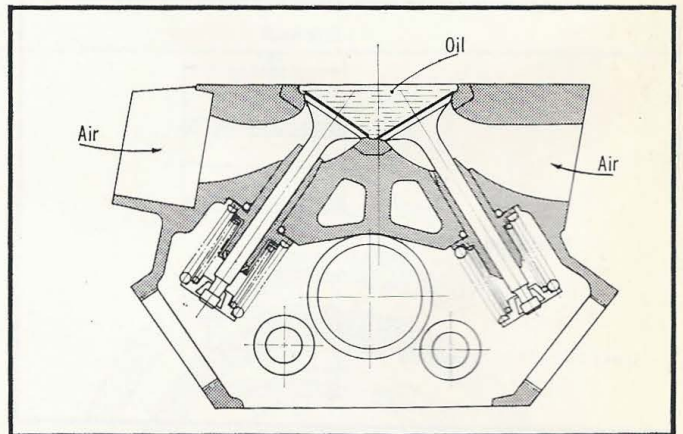

Figure 3-27. Inspecting valve seat contact

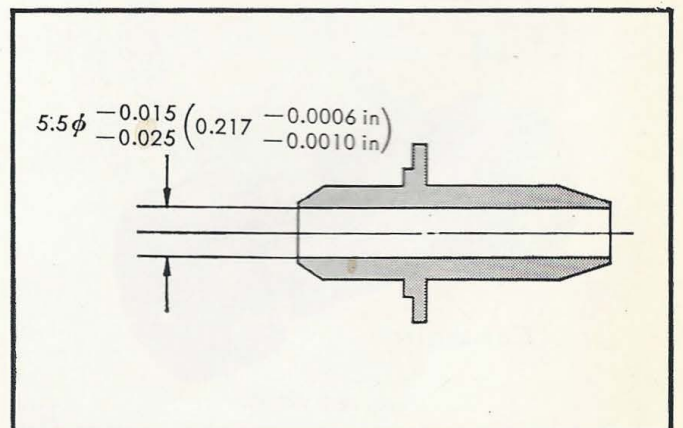

Figure 3-28. Valve guide

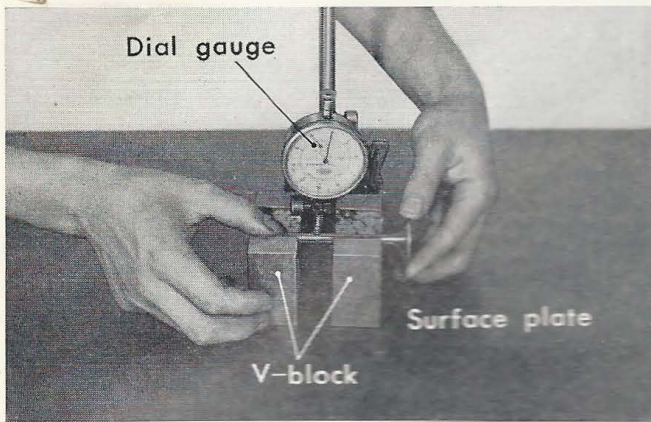

Figure 3-29. Measuring valve stem diameter

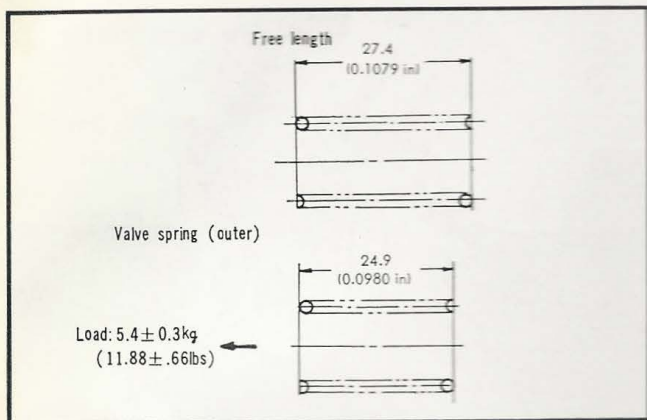

Figure 3-30. Outer valve spring

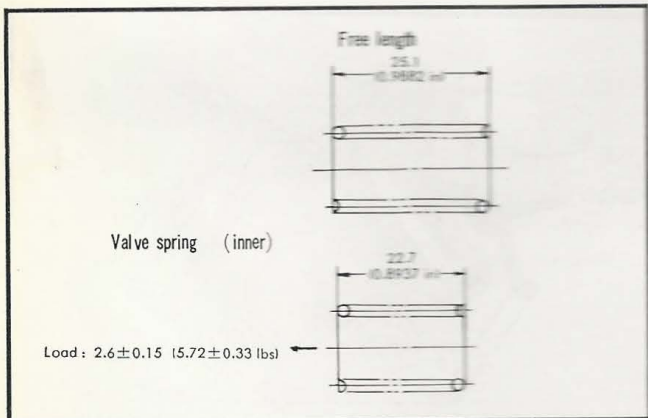

Figure 3-31. Inner valve spring

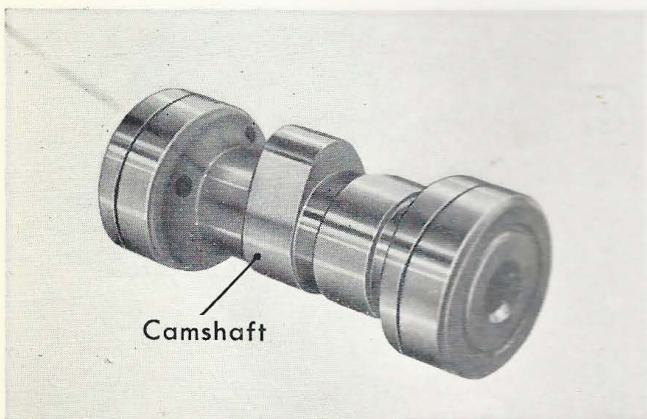

Figure 3-32. Camshaft

(3) Inlet valve, [] values are for C50, C50M, S50

	Standard Value	Serviceable Limit
Length	64.5 (2.540 in.) [66] (2.600 in.)	Replace if under 64.1 (2.580 in.) [65.6] (2.530 in.)
Stem dia	5.5 mm (0.217 in.) -0.035 (0.0014 in.) -0.045 (0.0018 in.)	Replace if under 5.44 (0.214 in.)
Head thickness	0.5 (0.020 in.) ±0.1 (0.004 in.)	Replace if under 0.2 (0.008 in.)

(4) Valve stem to guide clearance, inlet

Standard value → 0.010 ~ 0.030 (0.0004 ~ 0.0012 in)

Serviceable limit → Replace if over 0.06 (0.0023 in)

(5) Valve stem to guide clearance, exhaust

Standard value → 0.030 ~ 0.050 (0.0012 ~ 0.0020 in)

Serviceable limit → Replace if over 0.08 (0.0032 in)

(6) Outer valve spring (Fig. 3-30)

	Standard Value	Serviceable Limit
Free length	27.4 (1.080 in.) [28.1] (1.110 in.)	Replace if under 26.2 (1.030 in.) [26.9] (1.060 in.)
Spring pressure	5.4 ± 0.30 kg/24.9 mm (11.9 ± 0.66 lbs/ 0.980 in.) 7.2 ± 0.55 kg/24.9 mm (16.0 ± 1.2 lb/0.980 in.) Replace if under 6.4/24.9 mm (14.0 lb/0.98 in.)	Replace if under 15.2 kg/19.7 mm (33.4 lb/0.780 in.)
Spring pressure	16.8 ± 0.8 kg/19.7 mm (37.0 ± 1.76 lb/ 0.780 in.) 19.0 ± 1.4 kg/19.7 mm (42.0 ± 3.1 lb/0.780 in.) Replace if under 17.3 kg/1.7 mm (38.0 lb/0.067 in.)	Replace if under 4.6 kg/24.9 mm (10 lb/0.980 in.)
Tilt	1°30'	Replace if over 2°
Free length	25.1 (0.990 in.)	Replace if over 23.9 (0.940 in.)

(7) Inner valve spring (Fig. 3-31)

	Standard Value	Serviceable Limit
Spring pressure	2.6 ± 0.15 kg/22.7 mm (5.7 ± 0.33 lb/0.890 in.)	Replace if under 2.0 kg/22.7 mm (4.4 lb/0.890 in.)
Spring pressure	8.2 ± 0.4 kg/17.5 mm (18.0 ± 0.88 lb/ 0.690 in.)	Replace if under 7.2 kg/17.5 mm (15.8 lb/0.690 in.)
Tilt	1°30'	Replace if over 2°

4. CAMSHAFT

In a four stroke cycle engine, the camshaft makes one revolution for every two revolutions of the crankshaft. The power to drive the camshaft is through the cam chain driven by the crankshaft sprocket.

The lubricating oil is pressure-fed into the right side of the camshaft and is forced out of the holes in the cam to lubricate the cam surfaces, rocker arms and the slippers. The camshaft is made of special cast steel with the cam and the bearing area being precisely ground after heat treatment. The camshaft is supported at both ends by the bearings in the cylinder head, a cam sprocket is installed on the left end of the camshaft with 6mm bolts and is driven at one half crankshaft speed by the timing sprocket press-fitted to the crankshaft end, by means of a light weight endless chain. (Fig. 3-23, 3-33)

The standard tappet clearances measured cold are 0.25mm (0.010 in) for both the inlet and exhaust. This is the clearance measured when the rocker arm is against the heel of the cam lobe; in order to obtain this condition, the crankshaft must be rotated so that the "T" timing mark on the flywheel is in line with timing mark on the left crankcase cover, otherwise, the rocker arm may be on the lifting slope of the cam. (Fig. 3-34)

The opening and closing of the valve is determined by the piston stroke and is timed to the crankshaft rotation. During the inlet cycle, the inlet valve is opened and closed at the end of the inlet cycle. During the exhaust cycle, the same opening and closing sequence takes place with the exhaust valve. The open angle between the opening and closing is the same as the piston travel, however, since it is the same as the crankshaft angular rotation, it is expressed in terms of angular rotation.

When point "a" in the Fig. 3-34 passes beyond the rocker arm, the vertical movement of the valve increases, and at a certain point where the cam lobe comes to a peak, the movement of the valve slows down and comes to a halt at point "b" on the cam.

The tappet clearance is adjusted when the rocker arm is at the exposed section of the heel of the cam between points "c" and "a". The heel of the cam on the S50 and S65 differs from the other models in that it is comparatively larger, this is to decrease the unit load on the slipper surface on the rocker arm.

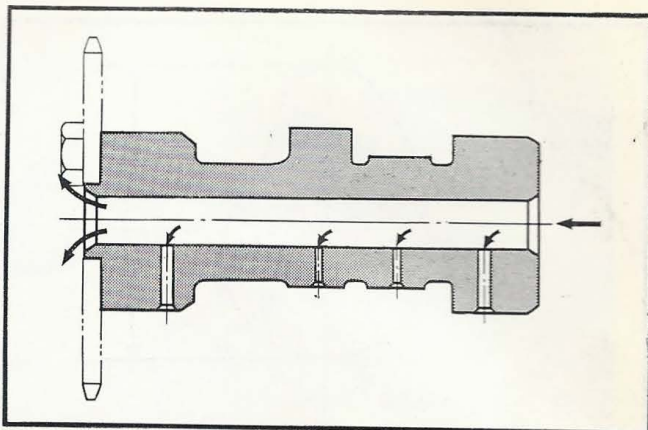

Figure 3-33. Camshaft construction (oil passage)

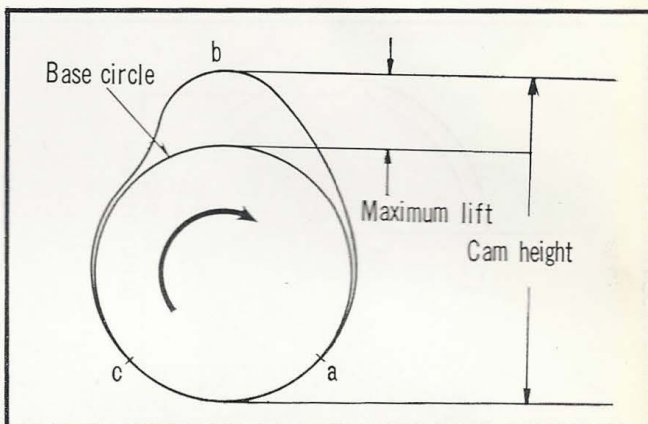

Figure 3-34. Cam contour

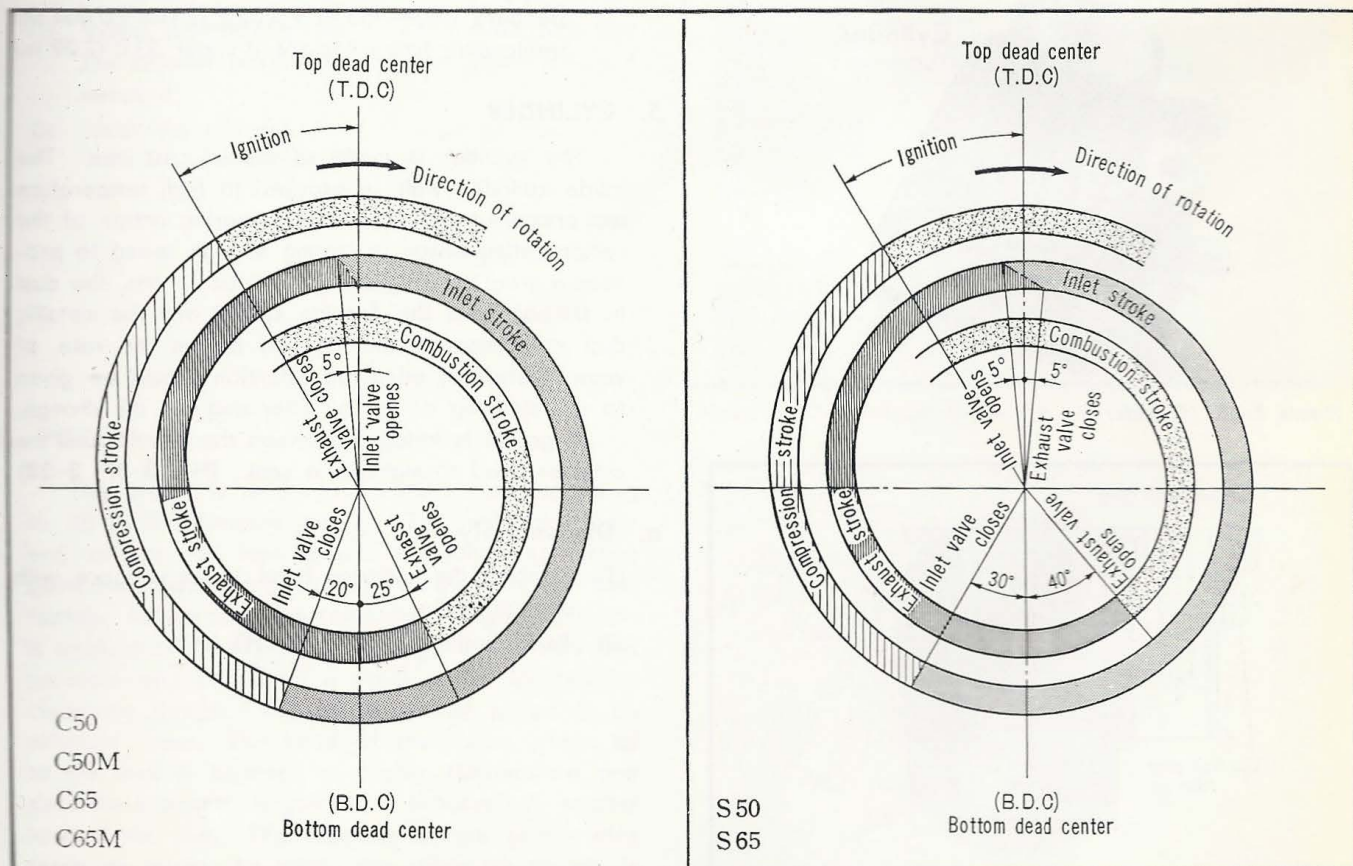

Figure 3-35. Valve timing diagram

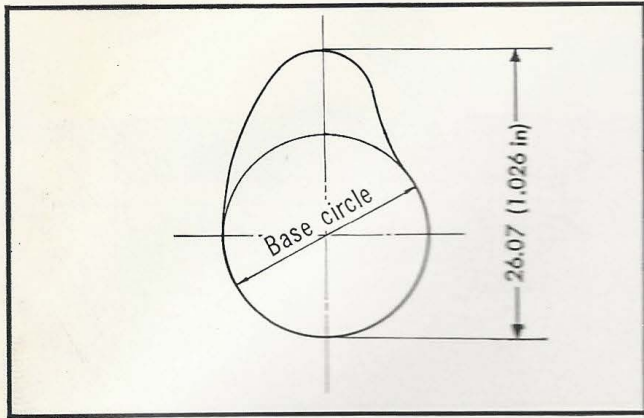

Figure 3-36. Camshaft height

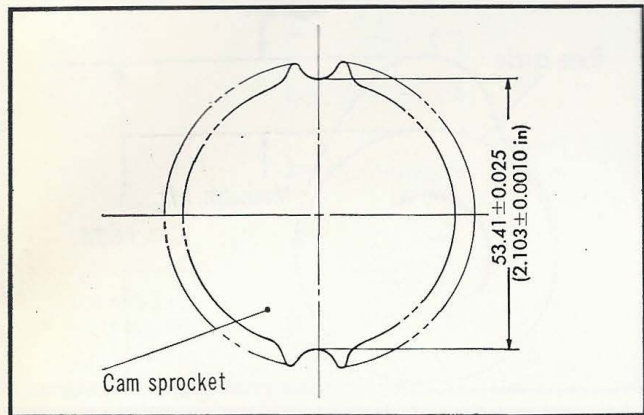

Figure 3-37. Cam sprocket teeth base contour

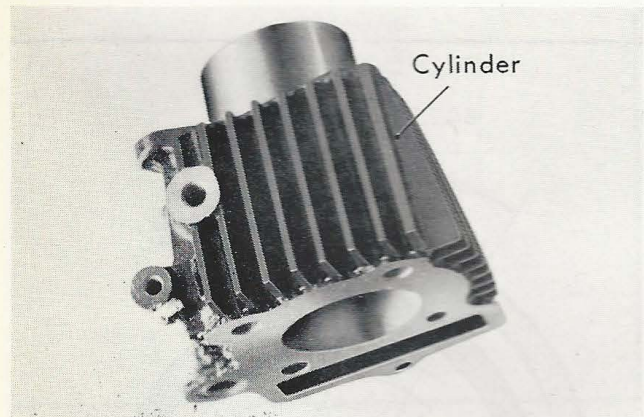

Figure 3-38. Cylinder

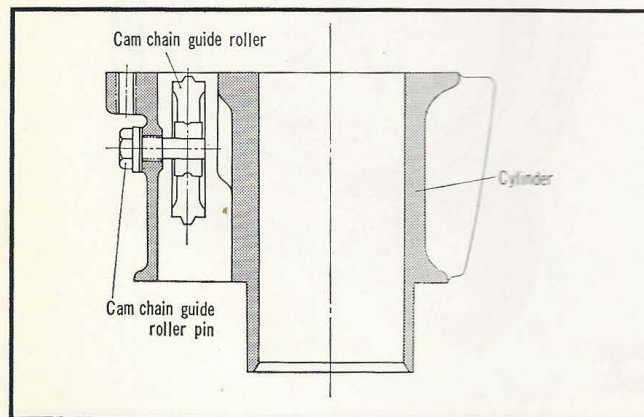

Figure 3-39. Cylinder cross section

The inlet valve opens at 5° (top dead center for C50, C50M, C65, C65M) before top dead center of the piston movement and closes at 30° (20° for C50, C50M, C65, C65M) after bottom dead center, permitting an open duration of 215° (200° for C50, C50M, C65, C65M). The exhaust valve opens at 40° (25° for C50, C50M, C65, C65M) before bottom dead center and closes 5° (5° before top dead center for C50, C50M, C65, C65M) after top dead center. This allows 225° (200° for C50, C50M, C65, C65M,) of exhaust valve open duration. This sequence is shown in Fig. 3-35 and is called the valve timing diagram.

a. Inspection

(1) Camshaft (Fig. 3-36)

	Standard Value	Serviceable Limit
Left end dia.	29 mm (1.140 in.) -0.060 (0.0020 in.) -0.073 (0.0030 in.)	Replace if under 28.8 (1.135 in.)
Right end dia.	"	"
Shaft runout		Replace if over 0.05 (0.0020 in.)
Cam height	5.076 (0.200 in.)	Replace if under 4.9 (0.190 in.)
Left end bearing dia	29 mm (1.140 in.) +0.021 (0.0008 in.) +0.00 (0.000 in.)	Replace if over 29.06 (1.145 in.)
Right end bearing dia	"	"

(2) Cam sprocket root diameter

Standard value $\rightarrow 53.41 \pm 0.025$ (2.104 \pm 0.001 in)

Serviceable limit \rightarrow Replace if under 53.0 (2.09 in)

5. CYLINDER

The cylinder is made of special cast iron. The inside cylinder wall is exposed to high temperature and pressure together with the wearing action of the reciprocating piston operating at high speed to produce a great wearing effect. Added to this, the dust in the air and the foreign object and the metallic dust contaminating the oil will hasten the rate of wear, therefore, adequate attention should be given to the cleaning of the air filter and the oil change.

A gasket is installed between the cylinder and the cylinder head to maintain a seal. (Fig. 3-37, 3-38)

a. Disassembly

- (1) Remove the cylinder head in accordance with section 3.21a.
- (2) Remove the 6mm cylinder HS bolts.

- (3) Remove the 6X14 hex bolt and draw out the cam chain guide roller, this will permit the cylinder to be separated from the crankcase. (Fig. 3-39, 3-40)

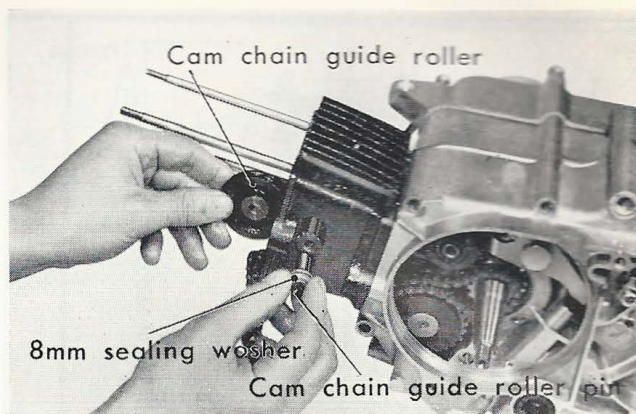

Figure 3-40. Removing cam chain guide roller

b. Inspection

- (1) Cylinder bore, [] is for C50, C50M, S50 (Fig. 3-41, 3-42)
 Standard value → 44mm [39mm] (1.750 in) [1.54 in]
 +0.02 (0.0008 in)
 +0.01 (0.0004 in)
 Serviceable limit → Repair by rehonng if over
 44.1 (1.74 in)
- (2) Cylinder oversize
 Standard oversize → 0.25 (0.01 in)
- (3) Cylinder barrel
 Standard value → 62.65 +0 (0.0000 in)
 (2.47 in) -0.1 (0.004 in)

c. Reassembly

- (1) When assembling the cylinder, make sure that the cylinder gasket and the two dowel pins are installed.
- (2) Install the cylinder.

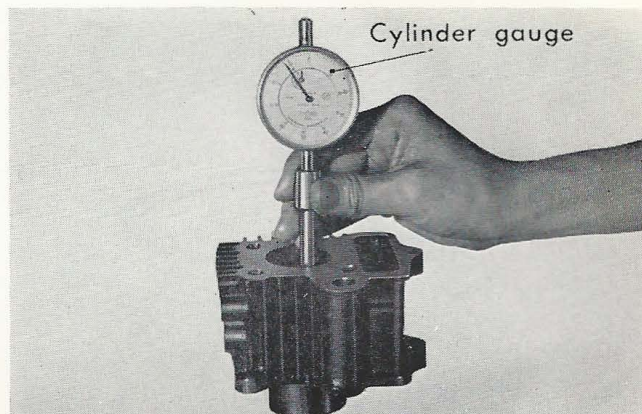

Figure 3-41. Measuring cylinder inside diameter

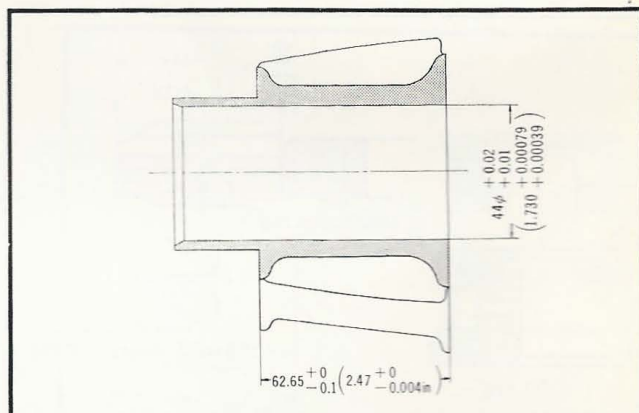

Figure 3-42. Cylinder dimensions

6. PISTON

The piston is made from material corresponding to JIS AC8B aluminum casting. This material is light and suitable for high speed, in addition to having good heat conducting property to dissipate the heat rapidly. Furthermore, the coefficient of heat expansion is small thus minimizing the warpage at elevated temperature and permitting a small piston to cylinder clearance design. The shape of the piston is an elliptical taper. The head of the piston, compared to the skirt, is exposed to higher temperature and since the expansion is greater, it is tapering smaller toward the top. The tapering of the piston also tends to lessen the piston slap when the throttle is lightly snapped without the engine being loaded.



Figure 3-43. Piston

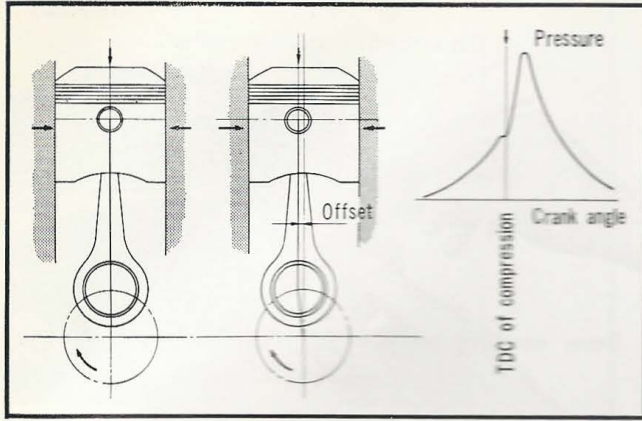

Figure 3-44. Cylinder offset

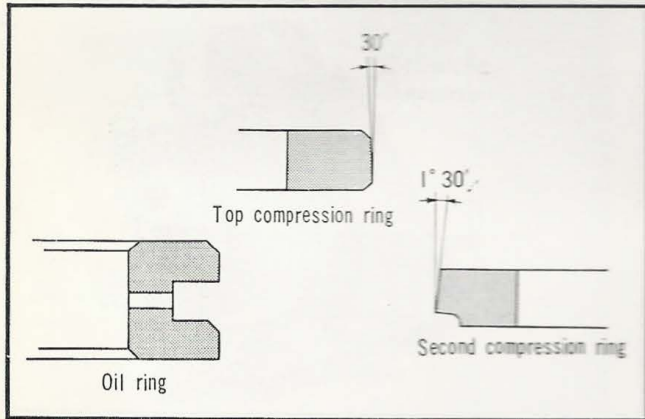

Figure 3-45. Piston ring

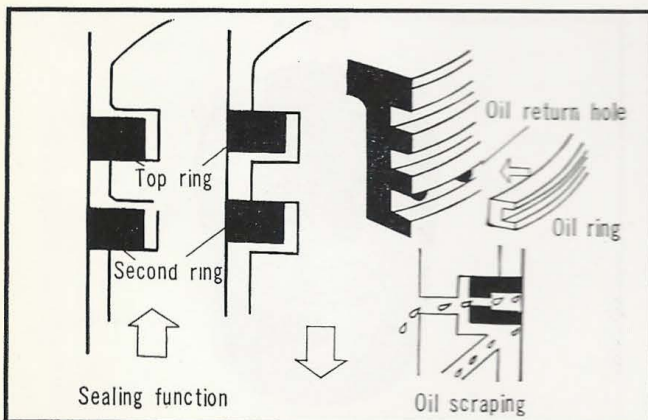

Figure 3-46. Piston ring sealing and oil scraping function

The piston employs a three step taper. The piston pin boss area is made thicker thereby resulting in greater expansion at high temperature. For this reason, the diameter of the piston skirt is made smaller in the direction of the piston pin so that at the high operating temperature, the piston will expand into a true circular shape. The skirt is constantly provided with flexibility to assure that no deformation will result even from extended continuous driving.

The piston pin is offset 1mm from the piston centerline in the direction of the inlet side. So that when the piston approaches the top dead center of the compression stroke, the side load from the cylinder moves from the right side to the left. With a "O" offset, the point will move to align with the top dead center of the compression stroke. (Fig. 3-43).

As shown in Fig. 3-44, the point of maximum combustion pressure occurs after the top dead center, therefore, the purpose of the offset is to move the point toward the point of weaker pressure which is before top dead center, and by so doing, escapes the powerful pressure movement and makes it possible to eliminate the piston slap.

7. PISTON RING

The top and the second ring serves as a seal for the combustion chamber, the oil ring scrapes the excess oil from the cylinder wall to control the cylinder wall lubrication. Further, they transmit the high temperature of the piston to the cylinder wall where it is dissipated out through the cylinder cooling fins. For this reason, a special alloy of cast iron is used to provide strength, wear resistance, heat resistance, and good heat conducting properties and which is given parkarizing treatment or ferrox coating. The top ring especially is plated on the outer surface with hard chrome and finished by wet-honing.

To prevent flutter, the thickness of the rings are made narrower and with the width increased, inertia is made smaller to increase the pressure against the cylinder wall. Further the top and the second rings are made at a slight taper where it contacts the cylinder wall so that the time required for wear-in is lessened. (Fig. 3-45, 3-47)

a. Disassembly

(1) Remove the clip and push out the piston pin.

(Caution)

Do not drop the clip into the case. (Fig. 3-48)

b. Piston and Piston Ring Inspection

(1) Remove the deposits from the top of the piston, inside and from the ring grooves without scratching or causing damages to the piston. Do not use sandpaper to perform this task.

(2) Piston [] are for C50, C50M, S50

	Standard Value	Serviceable Limit
Piston crown dia.	43.5 mm (1.710 in.) +0 (0.000 in.) -0.05 (0.002 in.)	
	38.6 (1.521 in.) (+0) (0.000 in.) (-0.05) (0.002 in.)	
Maximum dia.	44 mm (1.734 in.) +0 -0.020 (0.001 in.)	Replace if under 43.9 (1.730 in.)
	39 (1.540 in.) +0 -0.02 (0.001 in.) D=44 mm (1.734 in.) +0 -0.020 (0.001 in.) 39 (1.540 in.) (+0) (0.000) (-0.02) (0.001 in.)	
Taper	D1 = D0 -0.070 (0.003 in.) -0.090 (0.004 in.) (-0.075) (0.0030 in.) (-0.095) (0.0037 in.)	
	D2 = D0 -0.230 (0.01 in.) -0.250 (0.01 in.) (-0.16) (0.006 in.) (-0.18) (0.007 in.)	
Eccentricity	0.168-0.188 (0.0066~0.0074 in.) [0.150~0.170] (0.0059~0.0067 in.)	

(3) Piston ring groove [] are for S50

	Standard Value	Serviceable Limit
Groove bottom dia.	39.4 mm (1.552 in.) +0 -0.1 (0.004 in.)	
	34.6 mm (1.363 in.) (+0) (-0.1) (0.004 in.)	
Thickness (top, 2nd)	1.2 (0.047 in.) +0.020 (0.0008 in.) +0.005 (0.0002 in.)	Replace if over 1.27 (0.50 in.)
Oil ring	2.5 (0.099 in.) +0.020 (0.0008 in.) -0 (0)	Replace if over 2.51 (0.989 in.)

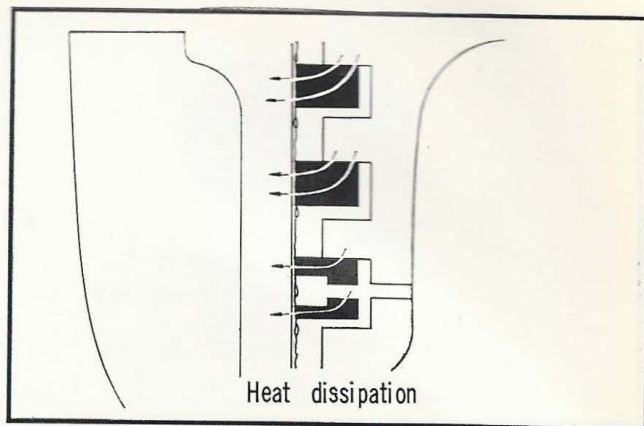

Figure 3-47. Piston ring heat transfer function

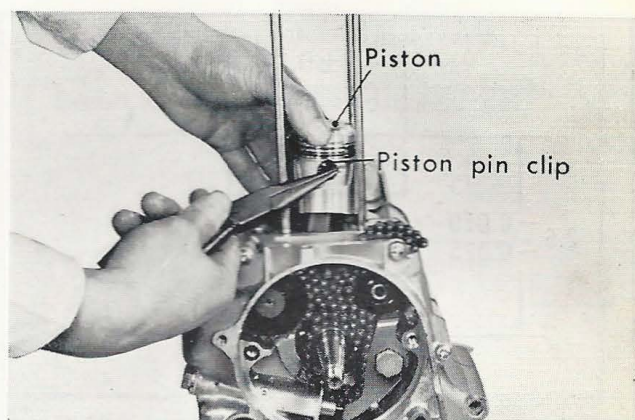

Figure 3-48. Removing piston

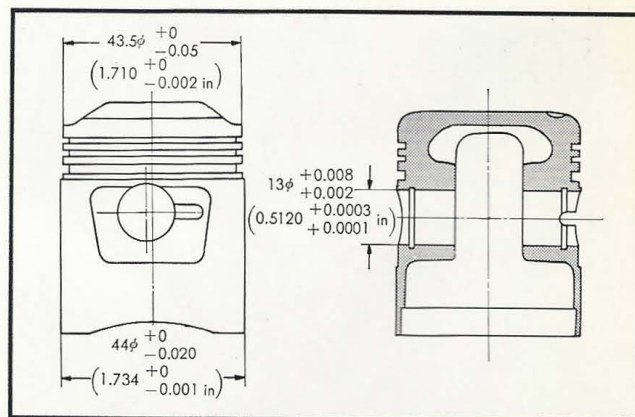

Figure 3-49. Piston dimensions

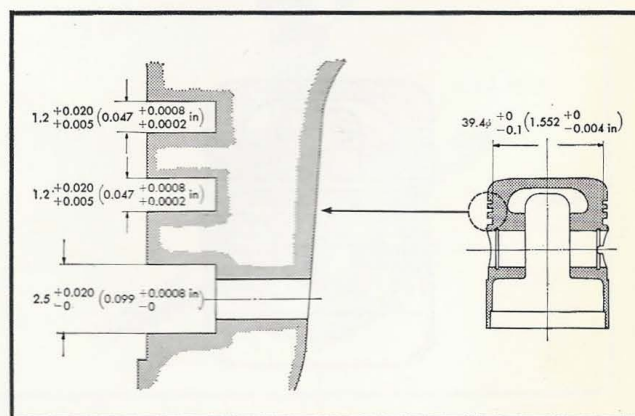

Figure 3-50. Piston ring groove dimensions

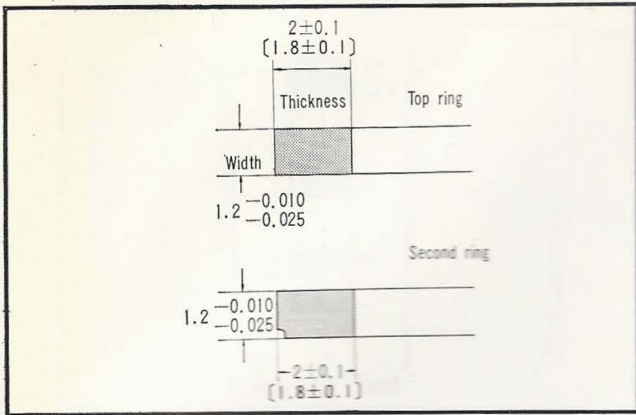

Figure 3-51. Piston compression rings (top and second)

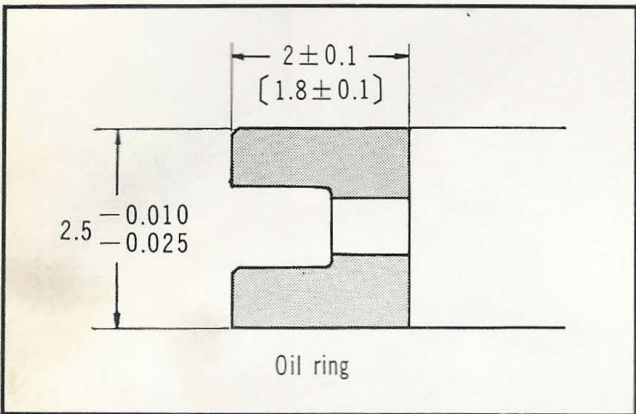

Figure 3-52. Piston oil ring [] for C50, C50M, S50

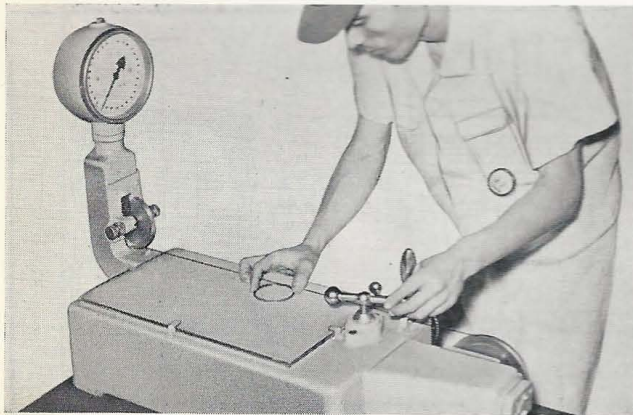

Figure 3-53. Measuring piston ring tension

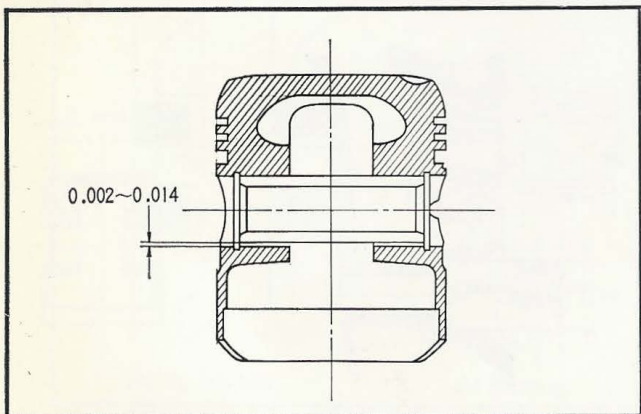

Figure 3-54. Piston pin clearance

- (3) Piston to cylinder minimum clearance
Standard value → 0.010 (0.0004 in)
Serviceable limit → Replace if over 0.12 (0.0047 in)
- (4) Piston pin bore
Standard value → 13mm $\begin{matrix} +0.008 \\ +0.002 \end{matrix}$ $\begin{matrix} (0.5120 + 0.0003 \text{ in}) \\ (0.5120 + 0.0001 \text{ in}) \end{matrix}$
Serviceable limit → Replace if over 0.12 (0.0047 in)
- (5) Oversize piston
Standard → 0.25 (0.0099 in)
- (6) Piston ring, compression, [] are for C50, C50M, S50 (Fig. 3-50, 3-51)

	Standard Value	Serviceable Limit
Width	1.2 (0.473 in.) -0.010 (0.0004 in.) -0.025 (0.0010 in.)	Replace if under 1.12 (0.044 in.)
Thickness	2 (0.079 in.) ±0.01 (0.04 in.)	Replace if under 1.8 (0.07 in.)
Ring closing force	0.3-0.6 kg (0.66~1.30 lbs) [0.16-0.44] (3.5~9.7 lbs) 0.35~0.65 kg (.77~1.43 lb) [0.34-0.62] (.75~1.36 lbs)	Replace if under 0.25 kg (55 lbs) [0.10] (22 lbs)
Ring end gap	0.15-0.35 (.0059~0.138 in.) [0.1-0.3] (0.004~0.0118 in.)	Replace if over 0.5 (0.0197 in.)

- (7) Side clearance, compression
Standard value → 0.015-0.045 (0.0006~0.00177 in)
Serviceable limit → Replace if over 0.12 (0.0047 in)
- (8) Oil ring [] are for C50, C50M, S50 (Fig. 3-52, 3-53)

	Standard Value	Serviceable Limit
Width	2.5 (0.099 in.) -0.010 (0.0004 in.) -0.025 (0.0010 in.)	Replace if under 24.2 (0.953 in.)
Thickness	2 ± 0.1 (0.099 ± 0.004 in.) [1.8 ± 0.1] (0.071 ± 0.0004 in.)	Replace if under 1.8 (0.071 in.) [1.6] (0.063 in.)
Ring closing force	0.5-0.8 kg (1.1~1.8 lb) [0.45~0.75 kg] (1.0~1.65 lb)	Replace if under 0.35 kg (0.77 lb) [0.30 kg] (0.66 lb)
Ring end gap	0.1~0.35 (0.004~0.014 in.) [0.30] (0.12 in.)	Replace if over 0.50 (0.020 in.)

- (9) Side clearance, oil ring
Standard value → 0.010~0.045 (0.0004~0.0017 in)
Serviceable limit → Replace if over 0.12 (0.005 in)
- (10) Oversize piston ring
Standard oversize → 0.25 (0.01 in)
- (11) Piston [] are for S50 (Fig. 3-54)

	Standard Value	Serviceable Limit
Outside dia	13 mm (0.512 in.) +0 (+0 in.) +0.006 (0.0002 in.)	Replace if under 12.98 (0.511 in.)
Height	35.4 (1.395 in.) +0.2 (0.008 in.) -0 (-0 in.) [30.7] (1.21 in.) +0.2 (0.008 in.) -0 (-0 in.)	

- (12) Piston pin to piston clearance
Standard value → 0.002~0.014 (0.00008~0.00055 in)
Serviceable limit → Replace if over 0.05 (0.0020 in)

(1) Assemble the piston.

(Caution)

Assemble the piston so that the arrow on the piston head is pointing toward the front. (Fig. 3-55)

(2) Install the piston pin locking clips.

(Caution)

- a. Install the clip so that the opening is not aligned with the clip groove cut out.
- b. Replace any clip that have lost its tension.

B. VALVE OPERATING MECHANISM

Both the inlet and exhaust valves are incorporated in the combustion chamber. The exhaust valve is designed smaller than the inlet valve to afford greater volumetric efficiency. The exhaust valve is constantly exposed to extremely high temperature, therefore, it is made of special high heat resisting material to withstand the high temperature as well as the wear.

The cam chain revolves at a very high speed within the cam chain chamber which is located on the left side of the cylinder, making it necessary to use a heat resistant as well as a wear resistant rubber on the cam chain guide sprocket and the cam chain tensioner roller to prevent chain noise. Further, in contrast to the conventional push rod type of a mechanism, this system has less reciprocating movement parts to cause hitting noises and therefore the operation is much smoother and quieter, making it very suitable for high speed, with the consequent increase in power output. (Fig. 3-56, 3-57)

a. Disassembly

- (1) Remove the cylinder head in accordance with section 3.21a.
- (2) The rocker arm is disassembled from the cylinder head by pulling out the rocker arm shaft. (Fig. 3-58)
- (3) Compress the valve spring with the valve lifter and after removing the valve cotter, the valve spring and the retainer can be removed. (Fig. 3-59)

b. Inspection

(1) Rocker arm

	Standard Value	Serviceable Limit
Slipper surface wear		Replace if over 0.3 (0.012 in.)
Shaft bore dia	10 mm (0.394 in.) +0.015 (0.0006 in.) -0 (-0 in.)	Replace if over 10.1 (0.398 in.)

(2) Rocker arm shaft

	Standard Value	Serviceable Limit
Outside dia	10 mm (0.394 in.) -0.013 (0.0005 in.) -0.022 (0.0009 in.)	Replace if under 9.91 (0.390 in.)
Clearance	0.013-0.037 (0.0005~0.0015 in.)	Replace if over 0.1 (0.004 in.)



Figure 3-55. Arrow marking on piston head

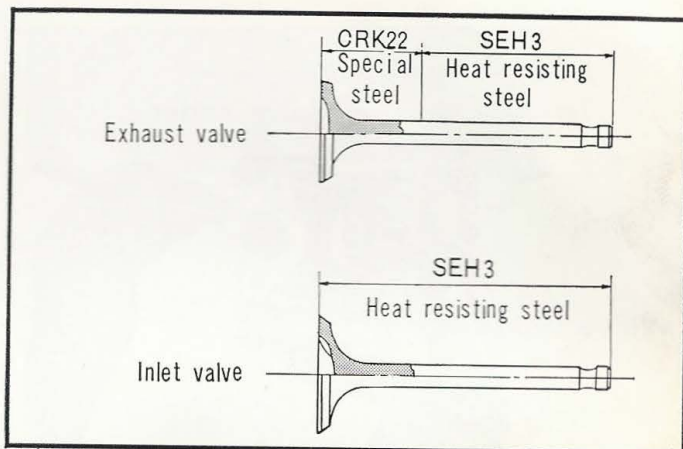

Figure 3-56. Valves

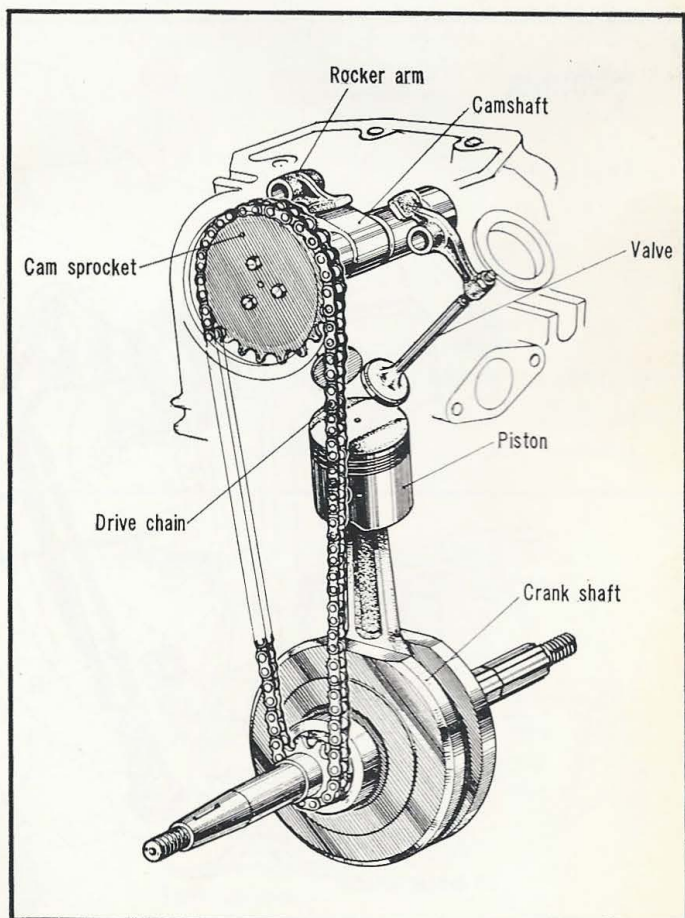

Figure 3-57. Valve operating mechanism

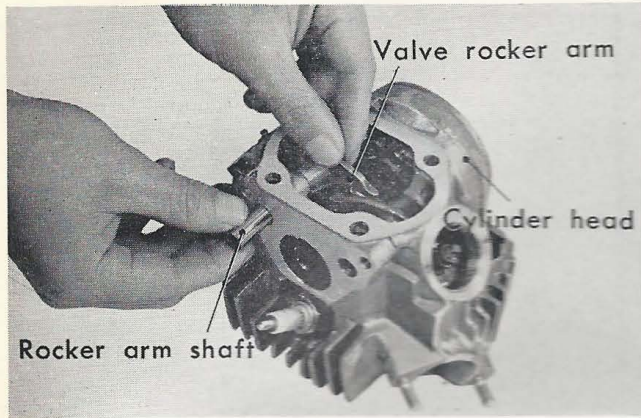

Figure 3-58. Removing the valve rocker arm

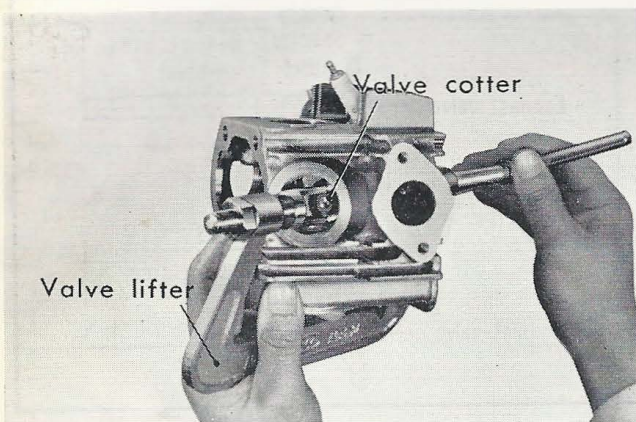

Figure 3-59. Removing valve cotter

- (3) Check for proper tappet clearance (both inlet and exhaust should be 0.05mm (0.002 in), too small a clearance will cause the valves to remain partly open, causing compression leak and result in hard starting.
- (4) Check for proper valve timing.
- (5) Check to see that the cam chain is not stretched.

c. Reassembly

- (1) Assemble in the same procedure as the disassembly with the use of the valve lifter.

9. CAM CHAIN TENSIONER

An oil damper type of a cam chain damper is employed to suppress the vibration of the cam chain, thereby, making it possible to control the cam chain for high speed operation and also preventing chain noise.

Before the engine starts, the chain tensioner spring compartment is flooded with the oil which enters from the oil damper strainer.

After the engine starts, the air remaining above the starting oil level in the tensioner spring compartment, passes from the hole A in the guide to hole B due to the reciprocating motion of the tensioner spring guide and enters the crankcase. When the engine starts the oil level rises above the oil hole B.

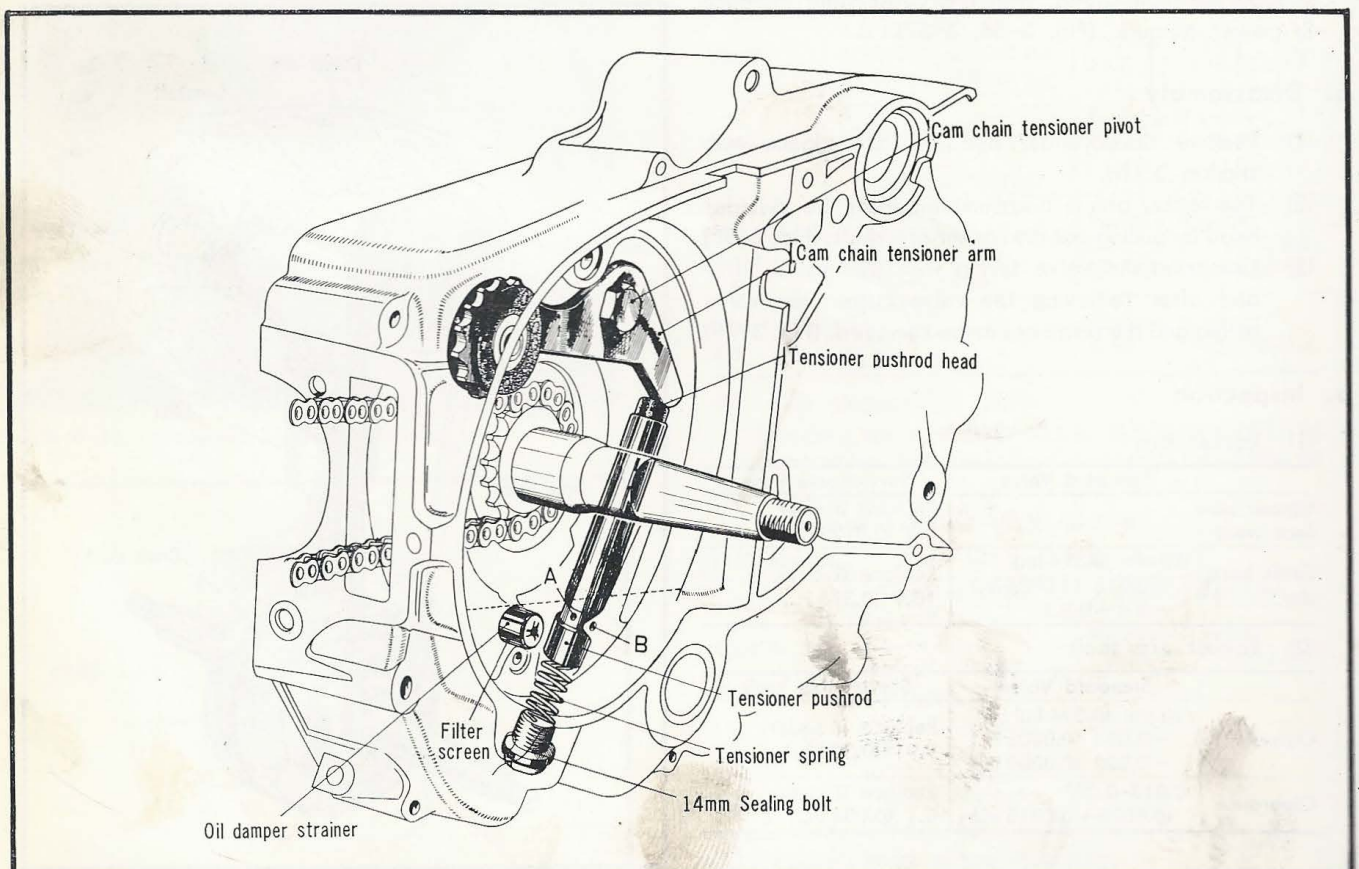

Figure 3-60. Cam chain tensioner detail diagram

In addition to the air in the tensioner spring compartment being ejected from hole A to B, the oil is sent into the tension spring compartment from hole B to A. In this way the tensioner spring compartment is constantly and completely flooded with oil, performing the function of a damper. Therefore, it is necessary to check the orifice of the tensioner spring guide and the operation of the tensioner spring. (Fig. 3-60)

a. Disassembly

- (1) Remove the flywheel and starter assembly.
- (2) The damper component parts may be disassembled by removing the 14mm sealing bolt.

b. Inspection

- (1) Cam chain tensioner spring. (Fig. 3-61)

	Standard Value	Serviceable Limit
Free length	77.2 (3.04 in.)	Replace if under 73.5 mm (2.89 in.)
Compression force	0.45 ± 0.04 kg / 22.2 mm (0.99 ± 0.08 lb / 0.874 in.)	Replace if under 0.36 kg / 22.2 mm (0.79 lb / 0.87 in.)

- (2) Cam chain tensioner roller diameter
 Standard value → 35.3mm (0.391 in)
 Serviceable limit → Replace if under 34.5mm (1.359 in)

c. Reassembly

- (1) Assemble the cam chain tensioner component parts. (Fig. 3-62)

(Note)

Check the operation of the tensioner after re-assembly.

3.3 RIGHT CRANKCASE COVER

The right crankcase cover is made of heat resisting aluminum alloy. An oil pump is incorporated into the right front lower section.

The oil delivered under pressure from the oil pump enters the right crankcase oil well and is diverted to the cylinder head and the right crankcase cover. (Fig. 3-63)

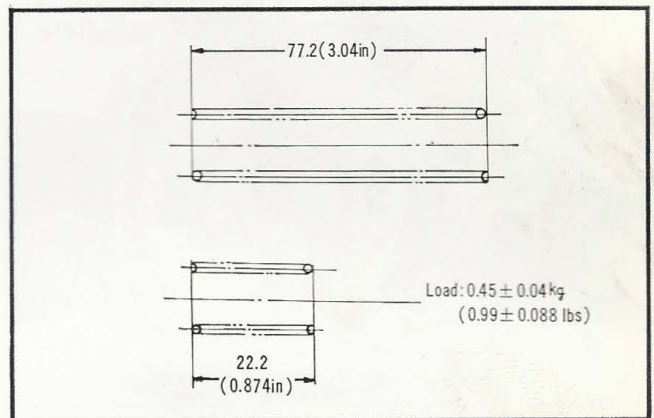

Figure 3-61. Cam chain tensioner spring

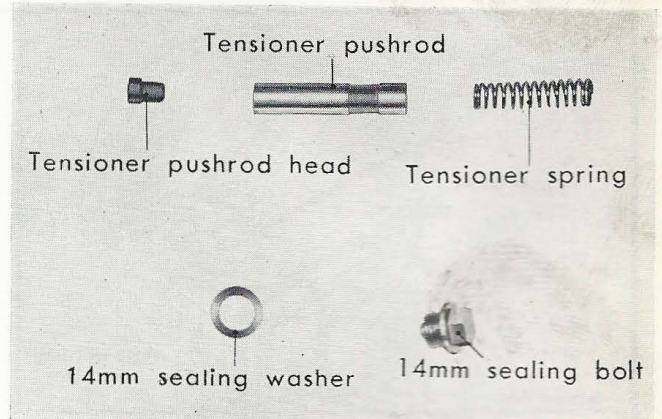

Figure 3-62. Component parts of cam chain tensioner

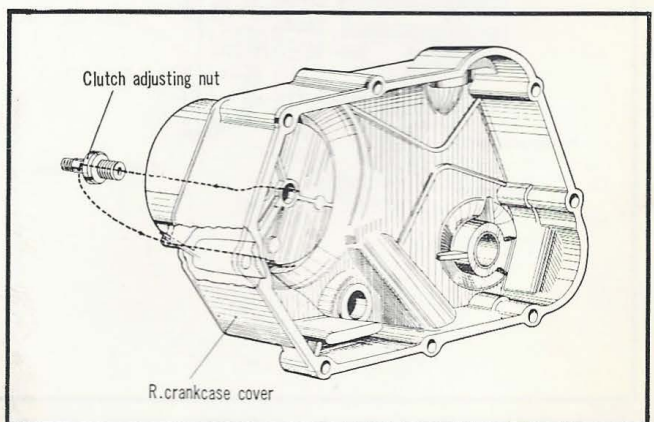

Figure 3-63. R. crankcase cover oil passage

a. Disassembly

- (1) Drain the oil from the crankcase.
- (2) Remove the kick starter arm.
- (3) Remove the 8mm locking nut from the clutch adjusting bolt. (C50, C50M, C65, C65M only)
- (4) Remove the right crankcase cover.

b. Reassembly

- (1) Reassemble in the reverse order of disassembly
(Caution)
 - a. Excercise caution not to damage the right crankcase cover gasket or to install it misaligned.
 - b. Install the kick starter arm by aligning the punch marks on the spindle and the arm.

1. CLUTCH

The function of the clutch is to temporarily disengage the transmitting of the rotary motion between the engine and the transmission during the gear change and then after the gear change, permit a smooth power transition. The condition of the clutch will have a varying effect on the direct transmission of the engine rotary output.

The clutch mechanism on the C50, C50M, C65 and C65M models are conventional wet type multiple disc, whereas, the S50 and S65 models incorporates a new clutch lift mechanism of further improve the smoothness of the clutch operation. (Fig. 3.64, 3.65A, 3.65B)

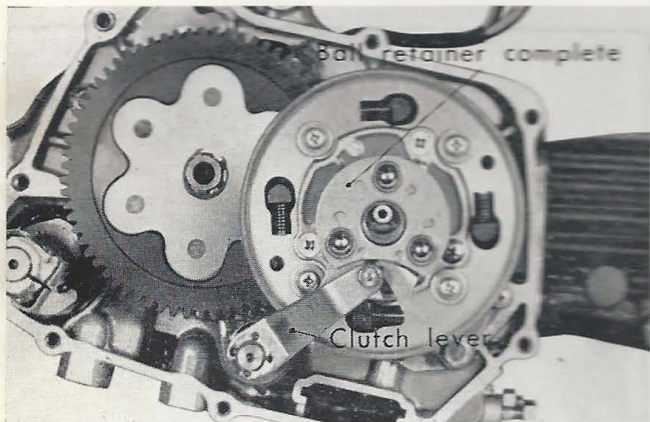

Figure 3-64. Gear shift and clutch mechanism

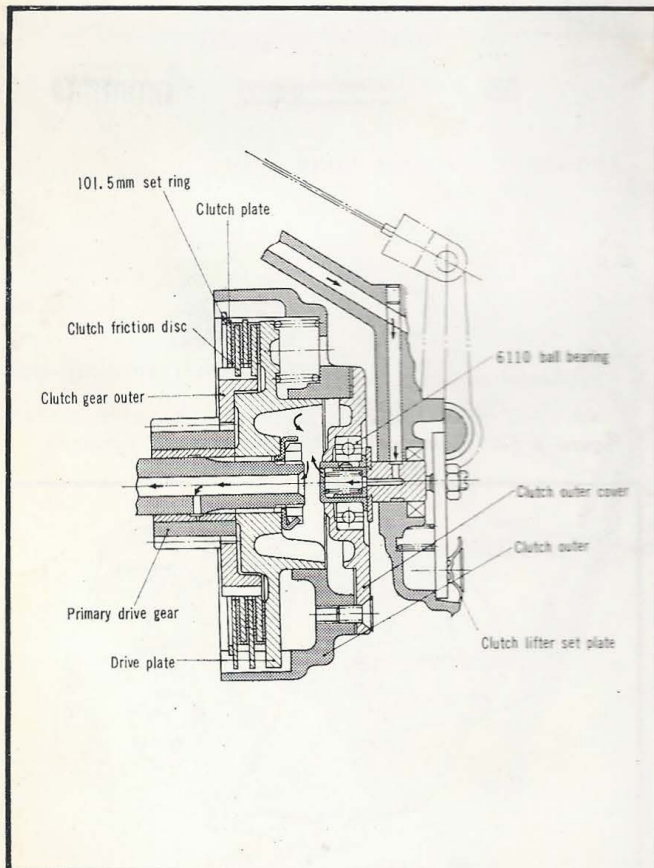

Figure 3-65A. Clutch assembly and oil passage diagram S50, S65

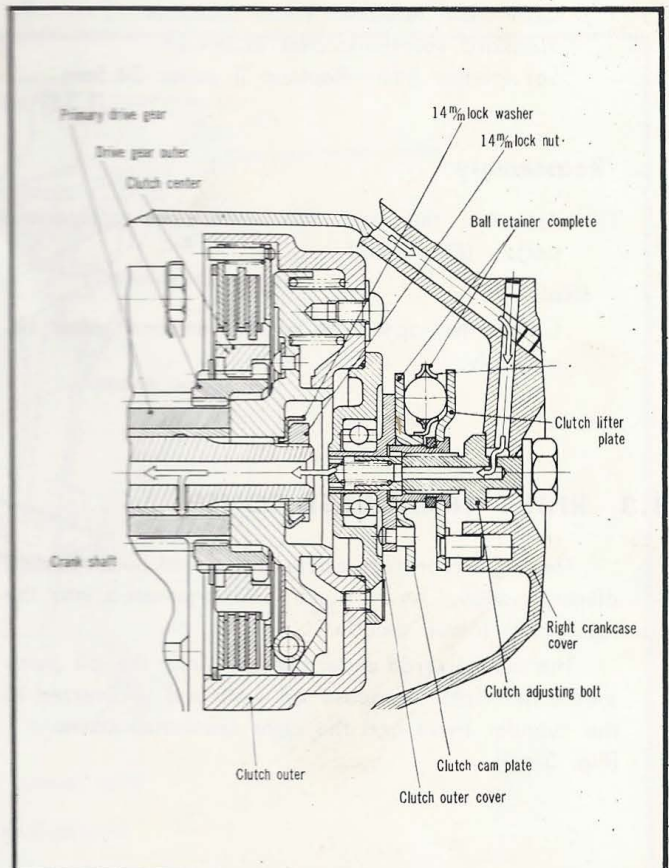

Figure 3-65B. (C50, C50M, C65, C65M)

a. Disassembly

- (1) Remove right crankcase cover.
- (2) Remove clutch outer cover.
- (3) Unlock the 14mm lock washer, remove the 14mm lock nut and the clutch can be removed as a complete unit.
- (4) The work of disassembling the clutch unit can be simplified by the use of special tools. (Fig. 3-66)

b. Inspection

- (1) Clutch center guide. (Fig. 3-67)

	Standard Value	Serviceable Limit
Inside dia	17 mm (0.670 in.)	Replace if over 17.1 (0.674 in.)
	+0.006 (0.0002 in.)	
	-0.012 (0.0004 in.)	
Outside dia	21 mm (0.827 in.)	Replace if under 19.98 (0.787 in.)
	-0.05 (0.002 in.)	
	-0.09 (0.0035 in.)	
Length	20.6 (0.812 in.)	Replace if under 20.4 (0.8 in.)
	+0 (0 in.)	
	-0.1 (0.004 in.)	
Runout	0.03 max. (0.0012 in.)	Replace if over 0.15 (0.006 in.)

- (2) Primary drive gear (Fig. 3-68) [] for C50, C50M, S50

	Standard Value	Serviceable Limit
Inside dia.	21 mm (0.830 in.)	Replace if over 21.15 (0.833 in.)
	+0.021 (0.0008 in.)	
	-0.00 (0.000 in.)	
Chordal distance across teeth (3 teeth)	13.723 (0.541 in.)	Replace if under 13.7 (0.540 in.)
	+0.021 (0.0008 in.)	
	-0.041 (0.002 in.)	
	$\left(\begin{array}{l} 14.001 -0.021 \\ -0.041 \\ 0.551 \text{ in.} -0.0008 \text{ in.} \\ \phantom{0.551 \text{ in.}} -0.002 \text{ in.} \end{array} \right)$	

- (3) Thickness of clutch friction disc.
Standard value→3.5 (0.138 in)
Serviceable limit→Replace if under 3.1 (0.122 in)
- (4) Clutch plate (Fig. 3-69)

	Standard Value	Serviceable Limit
Width of claw	16 (0.630 in.)	Replace if under 15.7 (0.620 in.)
	+0 (+0 in.)	
	-0.1 (0.004 in.)	
Thickness	1.6±0.05 (0.063±0.0020 in.)	Replace if under 1.5 (0.059 in.)

- (5) Width of clutch outer claw groove
Standard value→ $16 \begin{smallmatrix} +0.1 \\ -0 \end{smallmatrix} \sim 16.3 \begin{smallmatrix} +0.1 \\ -0 \end{smallmatrix}$
 $\left(0.63 \begin{smallmatrix} +0.004 \\ -0 \end{smallmatrix} \sim 0.642 \begin{smallmatrix} +0.004 \\ -0 \end{smallmatrix} \text{ in} \right)$

Serviceable limit→16.5 (0.65 in)

- (6) Clearance between the clutch outer and drive plate or with the clutch plate, in the direction of rotation.
Standard value→0.3~0.5 (0.012~0.02 in)

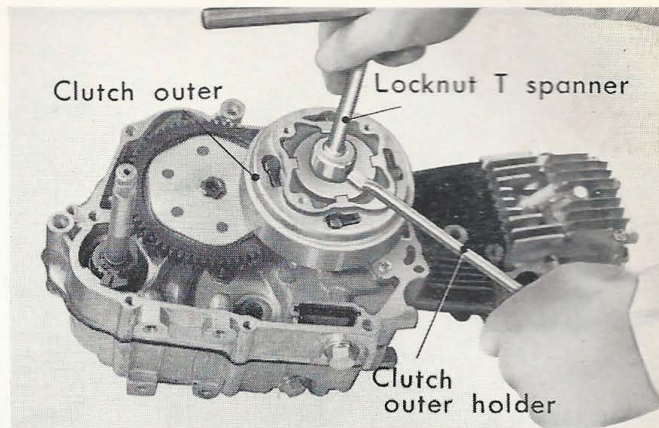

Figure 3-66. Removing clutch unit

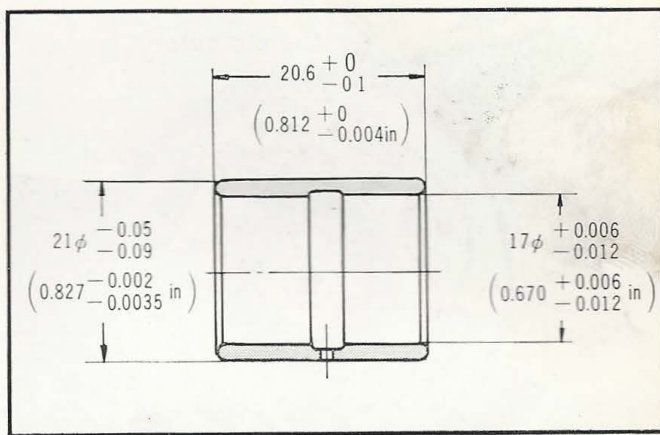

Figure 3-67. Clutch center guide

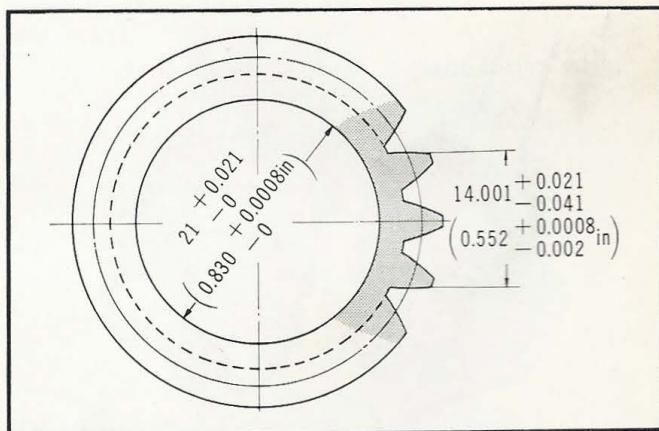

Figure 3-68. Primary drive gear

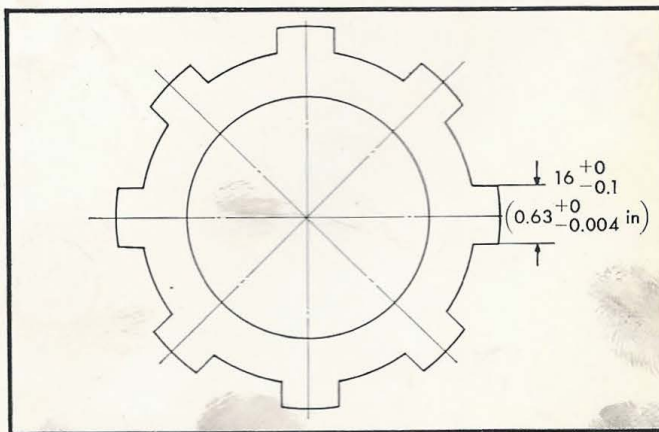

Figure 3-69. Clutch plate tab width

(7) Clutch spring S65 [] are for S50

	Standard Value	Serviceable Limit
Free length	19.2 (0.756 in.) [18.9] (0.744 in.)	Replace if under 18.2 (0.717 in.)
Spring force	7.5±0.5 kg/12.8 mm (16.5±1.1 lb/0.504 in.) 13.2±0.8 kg/12.8 mm (29.0±1.75 lb/ 0.504 in.)	Replace if under 6.5 kg/12.8 mm (14.3 lb/504 in.)

(8) Clutch spring (C50, C50M, C65, C65M)

	Standard Value	Serviceable Limit
Free length	19.6 (0.772 in.)	Replace if under 18.2 (0.720 in)
Spring force	5.85 kg±0.3 kg/ 13.5 mm (12.8±0.66 lb/ 0.532 in.)	Replace if under 5.0 kg/13.5 (11.0 lb/0.532 in.)

c. Reassembly

(1) Reassemble the clutch in the reverse procedure of disassembly.

(Note)

The lock washer must be locked by bending the tab after tightening the nut; if the nut does not align with the tab, tighten the nut further to permit locking. (Fig. 3-70)

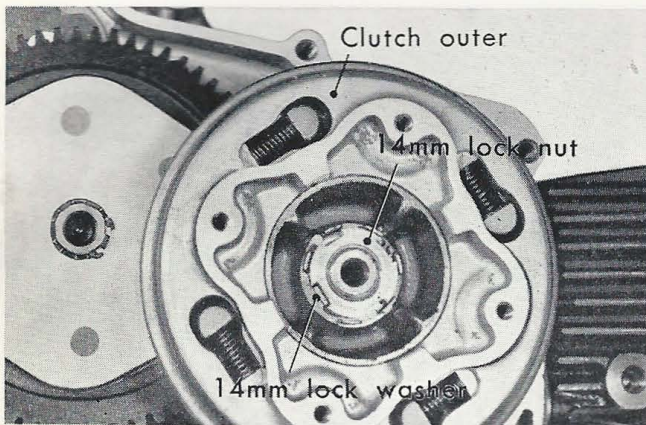

Figure 3-70. Bend up tab of lock washer

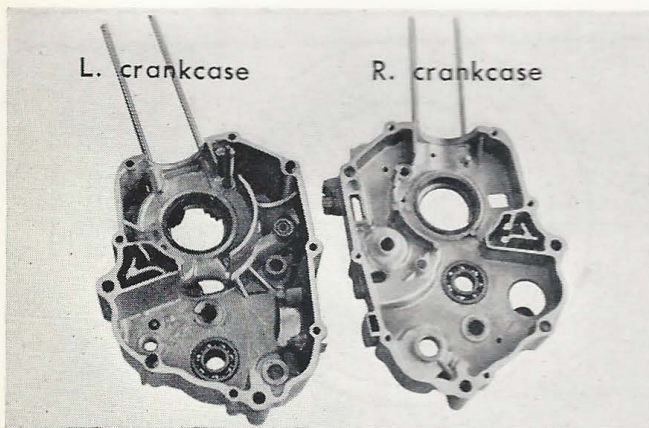

Figure 3-71. R & L crankcase

2. CRANKCASE

The crankcase, which is an integral part of the transmission, is an aluminum alloy die casting composed of right and left halves. A breather compartment and a breather passage is incorporated in the upper section of both crankcase halves to dissipate the pressure built up in the crankcase. (Fig. 3-71)

3. BREATHER

The interior of the crankcase is continually under varying pressure, built up by the reciprocating piston, in addition, the crankcase is filled with gases from the blow-by of the piston and the gases produced by the heat of the crankcase. For this reason, the decomposition of the oil is hastened. In addition, together with the rise in the crankcase internal pressure, the possibility of oil leaks at the case parting area is increased.

The breather is designed and incorporated in the case to exhaust the gases to the outside and also to maintain a constant pressure within the crankcase.

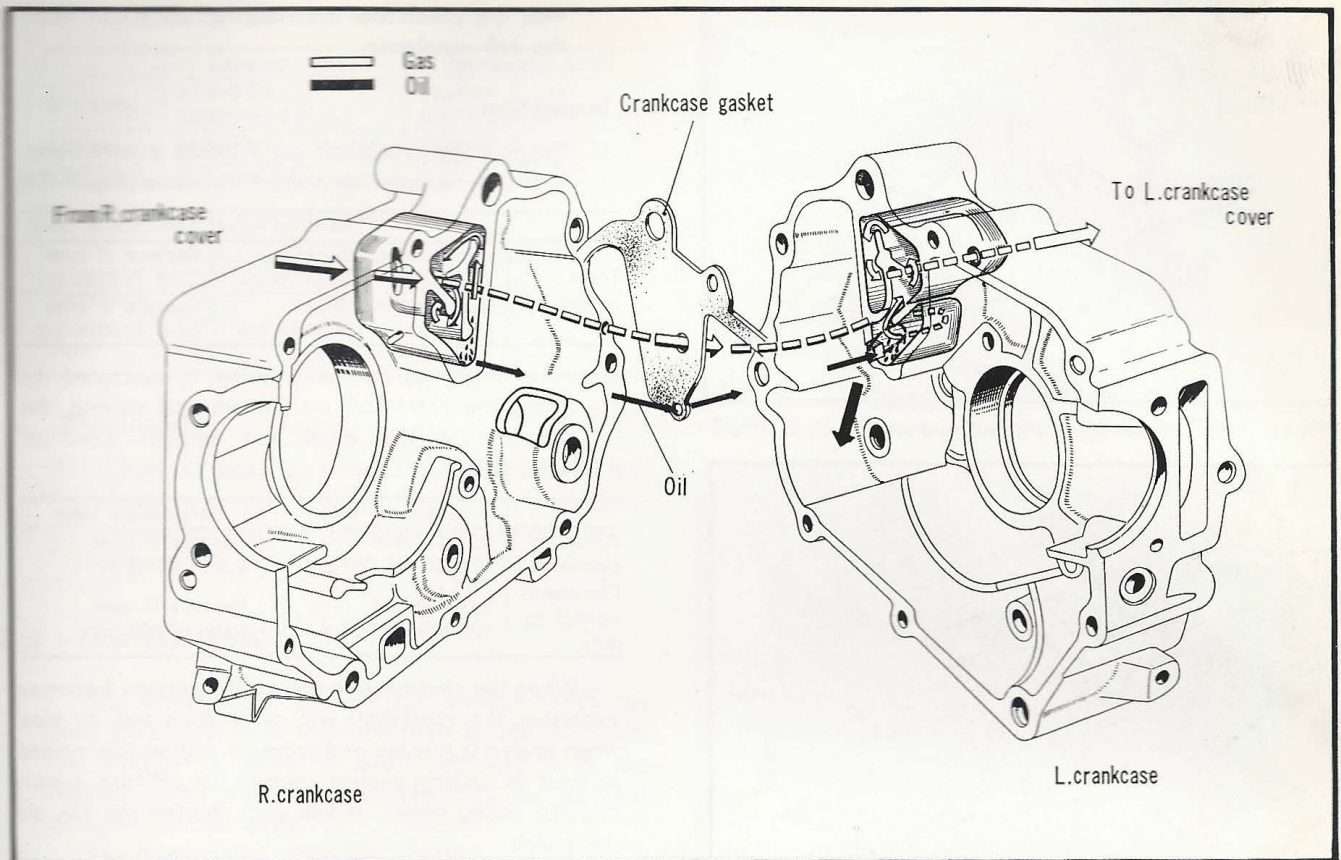

Figure 3-72. Breather functional diagram

3.4 CRANKSHAFT

The crankshaft is constructed of high strength carbon steel and together with the connecting rod, converts the reciprocating motion of the piston to the rotary motion and, in addition, performs the function of the flywheel by absorbing the fluctuating torque.

The pressurized oil from the pump passes from the right crankcase, through the right crankcase cover, into the crankshaft by the way of the centrifugal filter, and lubricates the large end of the connecting rod and clutch center guide. (Fig. 3-73)

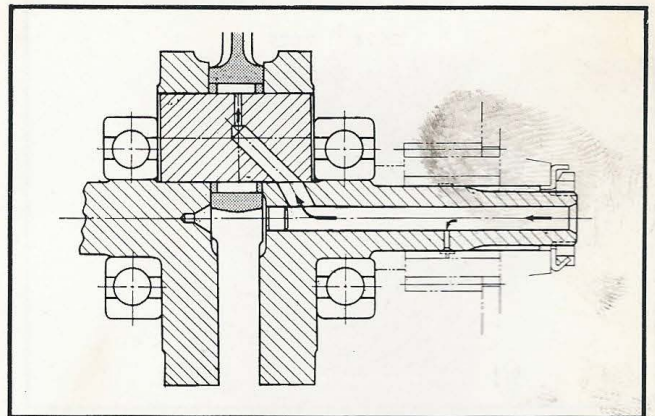

Figure 3-73. Crankshaft

a. Disassembly

- (1) Remove the clutch assembly as a unit.
- (2) Draw out the gear shift spindle.
- (3) Remove the kick starter spring.
- (4) Remove the flywheel and stator assembly.
- (5) Disassemble the cylinder head and cylinder.
- (6) Remove the oil pump and after separating the right crankcase, the crankshaft assembly together

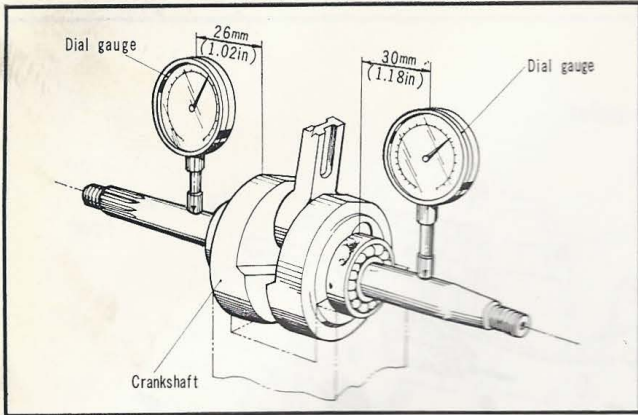

Figure 3-74. Measuring crankshaft alignment

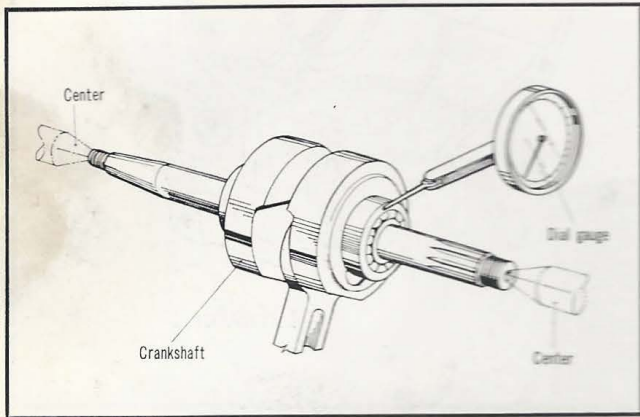

Figure 3-75. Measuring axial clearance

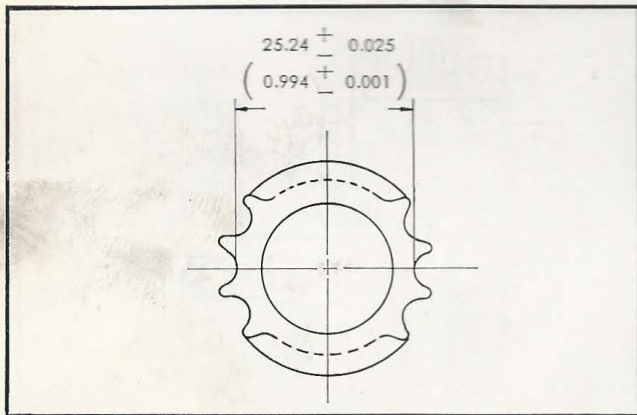

Figure 3-76. Timing sprocket teeth root contour

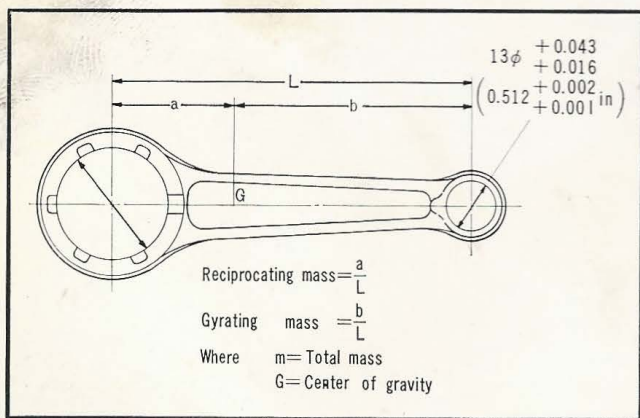

Figure 3-77. Connecting rod

with the piston can be removed as a unit from the left crankcase.

b. Inspection

- (1) Support the crankshaft on V blocks at both bearings and measure the amount of runout. (Fig. 3-74)

		Standard Value	Serviceable Limit
Total runout	Left bearing web side	0.015 (0.0006 in.)	Replace if over 0.05 (0.0020 in.)
	Right bearing web side	0.015 (0.0006 in.)	Replace if over 0.05 (0.0020 in.)

- (2) The clearance in the bearing is measured by fixing the crankshaft on centers and moving the bearing in the axial and vertical direction. (Fig. 3-75)

	Standard Value	Serviceable Limit
Axial clearance	0.004-0.036 (0.0002~0.001 in.)	Replace if over 0.1 (0.004 in.)
Clearance normal to axis	0.010-0.025 (0.0004~0.001 in.)	Replace if over 0.05 (0.002 in.)

When the clearance in the axial direction becomes excessive, the crankshaft will move from side to side when engine is running and produce undesirable noises as well as causing uneven wear to the cylinder, piston and the timing gear. It will also shorten the life of the clutch.

If the clearance is too small, it will cause a decrease in the power output and shorten the life of the crankshaft.

- (3) Crank pin

	Standard Value	Serviceable Limit
Outside dia	23.1 mm (0.91 in.) +0.012 (0.0005 in.) -0.002 (0.0001 in.)	Replace if under 23.045 (0.908 in.)
Interference	0.052~0.087 (0.0020~0.0034 in.)	

- (4) Left crankshaft sprocket root diameter. (Fig. 3.76)
Standard value → 25.24 ± 0.025 (0.994 ± 0.001)
Serviceable limit → Replace if under 25.19 (0.991 in)

- (5) Right crankshaft spline play
Standard value → 0.010 ~ 0.040 (0.0004 ~ 0.0020 in)
Serviceable limit → Replace if over 0.08 (0.0032 in)

- (6) Maximum crankshaft assembly runout
Standard value → runout at web outer surface
0.05 TIR (0.002 in)
Serviceable limit → Replace if over 0.2 (0.008 in)

- (7) Connecting rod small end I. D. (Fig. 3-77)
Standard value → 13mm +0.043 +0.016
(0.512 +0.002 +0.001 in)
Serviceable limit → Replace if over 13.1 (0.52 in)

- (8) Connecting rod small end to piston pin clearance
Standard value → 0.016 ~ 0.043 (0.001 ~ 0.002 in)
Serviceable limit → Replace if over 0.08 (0.0032 in)

- (9) Connecting rod small end deflection.
Standard value → 1.5 (0.060 in)
Serviceable limit → Replace if over 3.0 (0.120 in)

(10) Connecting rod large end

	Standard Value	Serviceable Limit
End play	0.10-0.35 (0.004~0.014 in.)	Replace if over 0.6 (0.024 in.)
Bearing clearance	0-0.012 (0~0.0005 in.)	Replace if over 0.05 (0.002 in.)

(11) Connecting rod alignment

	Standard Value	Serviceable Limit
Parallelism		Replace if over 0.10 (0.004 in.)
Twist		Replace if over 0.15 (0.006 in.)

c. Reassembly

- Check to make sure that the gasket and the two dowel pins are installed on the left crankcase before assembling the right crankcase to it. (Fig. 3-78)

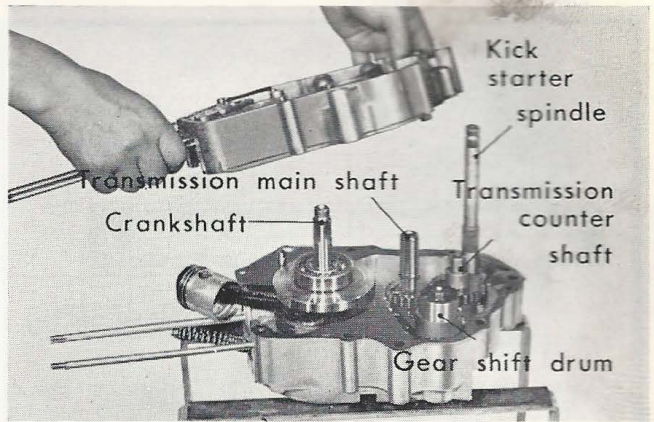

Figure 3-78. Assembling R crankcase

3.5 TRANSMISSION

The transmission receives the rotation which has been transferred from the crankshaft to the main shaft and through a series of gears, changes it to the desired speed and then transmits it to the sprocket mounted counter shaft.

The C50, C50M, C65 and C65M have a 3 speed transmission, whereas, the S50 and S65 have a 4 speed transmission. (Fig. 3-79, 3-80)

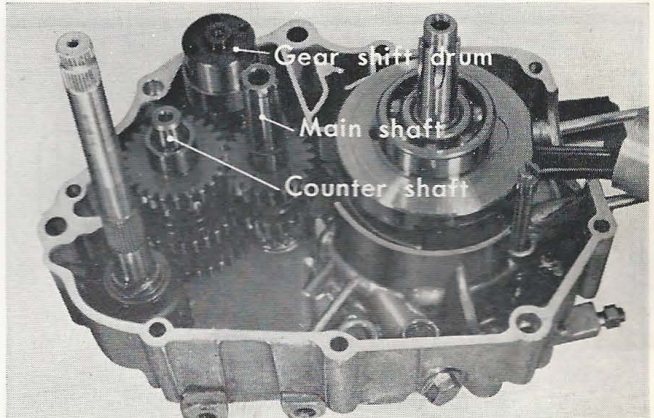

Figure 3-79. Transmission construction detail

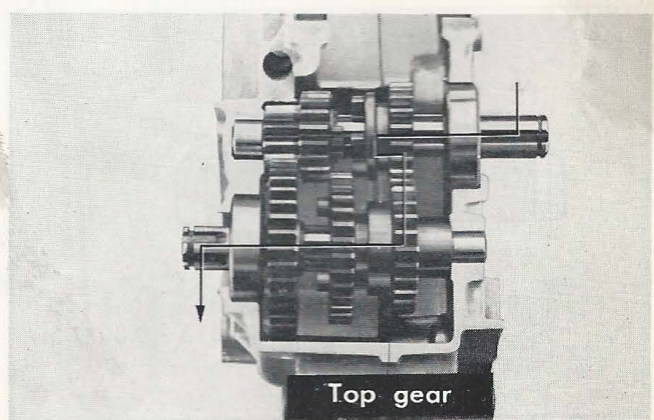
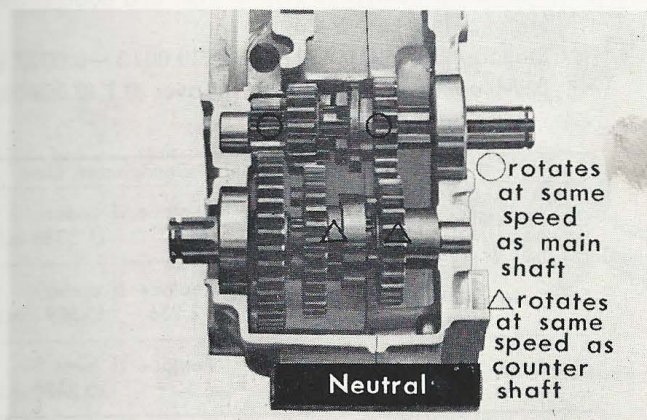
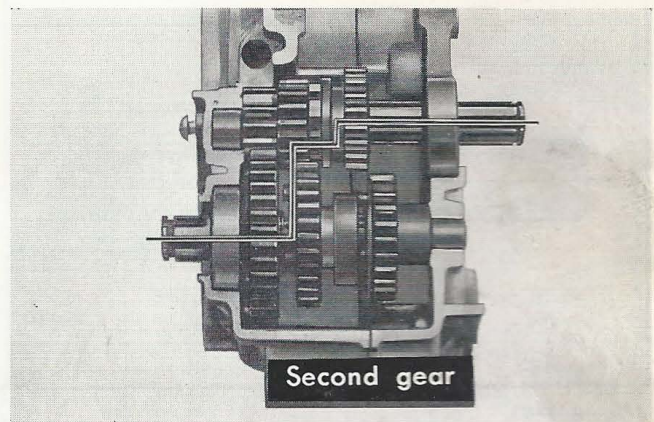
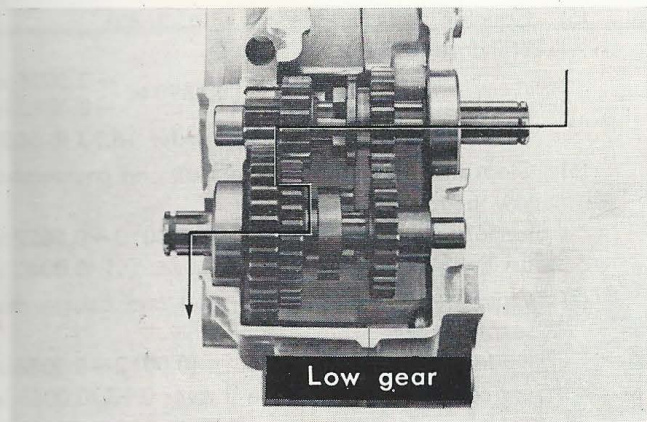

Figure 3-80. Gearing arrangement for C50, C50M, C65, C65M

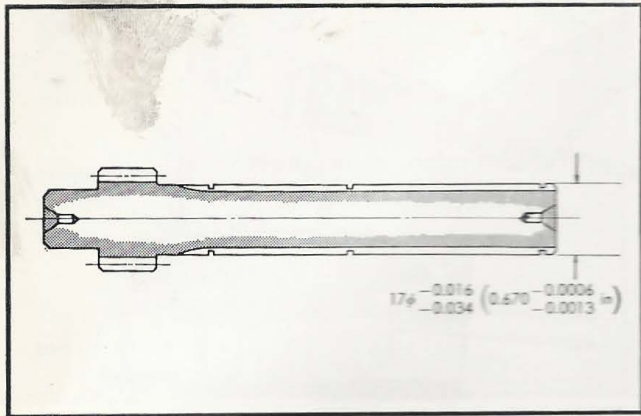

Figure 3-81. Main shaft dimension

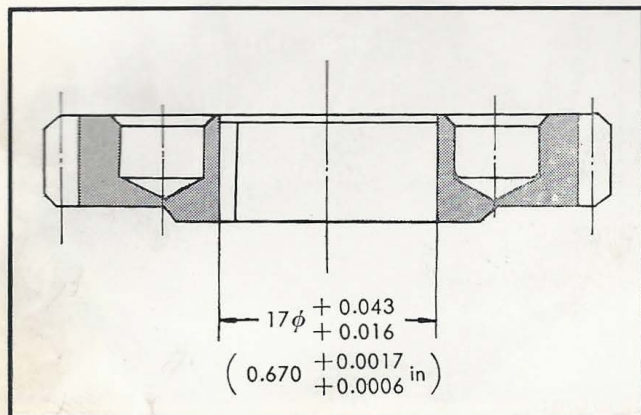

Figure 3-82. Main shaft, top gear dimension

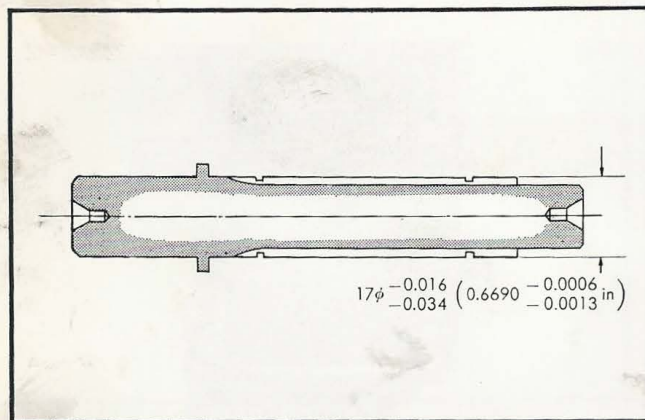

Figure 3-83. Counter shaft dimension

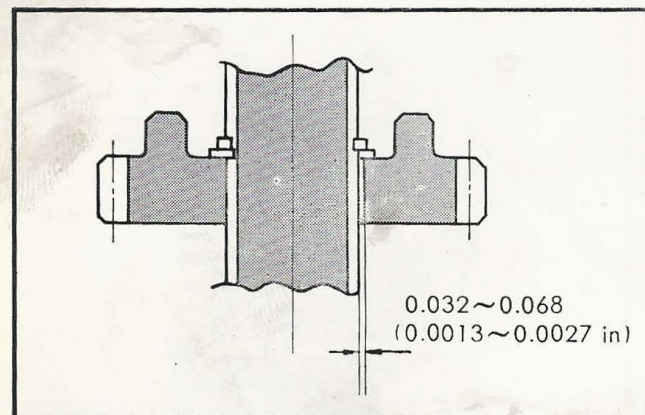

Figure 3-84. Clearance between counter shaft and counter shaft third gear

a. Disassembly

- (1) Disassemble the right crankcase in accordance with section 3
- (2) Disengage the kick starter spindle

b. Inspection

- (1) Primary driven gear backlash
Standard value → 0.047 ~ 0.094 (0.0019 ~ 0.0039 in)
Serviceable limit → Replace if over 0.12 (0.0047 in)
- (2) Clearance between main shaft and main shaft gear
Standard value → 0.022 ~ 0.051 (0.0009 ~ 0.0020 in)
Serviceable limits → Replace if over 0.1 (0.004 in)
- (3) Main shaft (Fig. 3-81, 3-82)

	Standard Value	Serviceable Limit
Outside dia	17 mm (0.670 in.)	Replace if under 16.93 (0.6670 in.)
	-0.016 (0.0006 in.)	
	-0.034 (0.0013 in.)	
End play	Tight	Replace if over 0.9 (0.0354 in.)
	0.05-0.59 (0.0020 ~ 0.0232 in.)	
Shaft to gear clearance	0.030-0.096 (0.0012 ~ 0.0037 in)	Replace if over 0.1 (0.0040 in.)
Top gear inside dia	17 mm (0.670 in.)	Replace if over 17.1 (0.6740 in.)
	+0.043 (0.0017 in.)	
	+0.016 (0.0006 in.)	

- (4) Clearance between main shaft, top gear and main shaft.
Standard value → 0.022 ~ 0.051 (0.0009 ~ 0.0020 in)
Serviceable limits → Replace if over 0.1 (0.0040 in)
- (5) Counter shaft outside dia (Fig. 3-83)
Standard value →
17mm -0.016 (0.6690 in -0.0006 in)
-0.034 (0.6690 in -0.0013 in)
Serviceable limit → Replace if under 16.93 (0.6653)
- (6) Clearance between countershaft and countershaft low gear
Standard value → 0.032 ~ 0.068 (0.0013 ~ 0.0027 in)
Serviceable limits → Replace if over 0.1 (0.0040 in)
- (7) Clearance between countershaft and countershaft second gear
Standard value → 0.030 ~ 0.096 (0.0012 ~ 0.0038 in)
Serviceable limits → Replace if over 0.15 (0.0059 in)
- (8) Clearance between countershaft and countershaft third gear (Fig. 3-84)
Standard value → 0.032 ~ 0.068 (0.0013 ~ 0.0027 in)
Serviceable limits → Replace if over 0.1 (0.0040 in)
- (9) Shift drum

	Standard Value	Serviceable Limit
Outside dia	34 mm (1.3386 in.)	Replace if under 33.93 (1.3358 in.)
	-0.02 (0.00079 in.)	
	-0.050 (0.0020 in.)	
Shaft dia	13 mm (0.5113 in.)	Replace if under 12.935 (0.5091 in.)
	-0.016 (0.0006 in.)	
	-0.034 (0.0013 in.)	
Width	6.1 (0.2402 in.)	Replace if over 6.3 (0.2480 in.)
	+0.1 (0.0040 in.)	
	-0 (-0 in.)	

3.6.1 Shift fork (Fig. 3-85)

	Standard Value	Serviceable Limit
Shaft dia	34mm (1.3386 in.)	Replace if over 34.025 (1.3414 in.)
End dia	+0.025 (0.0010 in.) -0 (-0 in.)	
To end	4.9 ± 0.04	Replace if under 4.8 (0.1811 in.)
Radius	0.1929 ± 0.0016 in.	

After completing the transmission reassembly and the installation of the right and left crankcase, inspect to ensure that the transmission operates properly. A transmission which runs heavy will cause malfunction or will heat up.

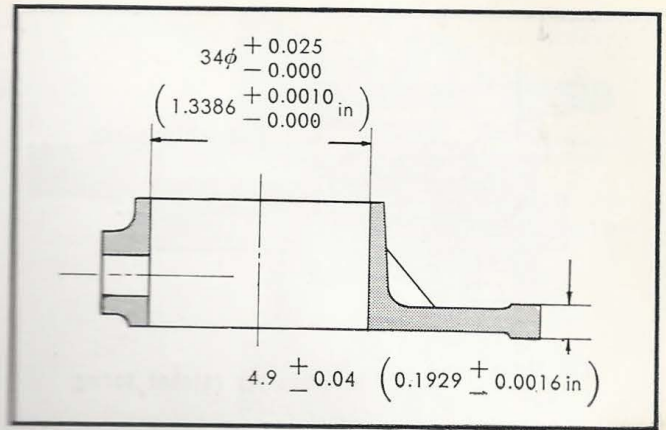

Figure 3-85. Shift fork

c. Reassembly

(1) Perform the operation in the reverse order of assembly.

(Note)

- a. Check to make sure the 12.5mm thrust washer is installed on the countershaft and the 14mm thrust washer is installed on the main shaft on C50, C50M, C65 and C65M. (Fig. 3-86)

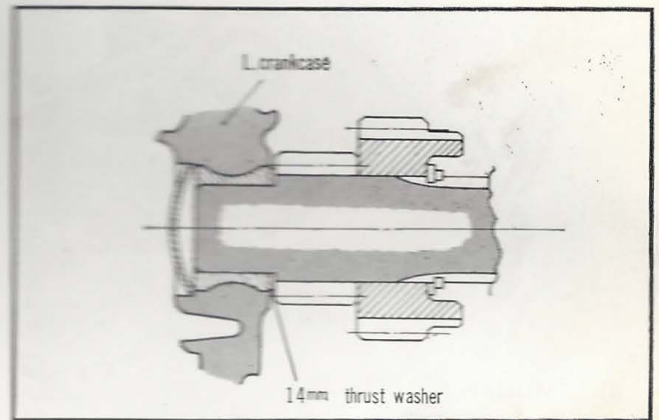

Figure 3-86. Thrust washer C50, C50M, C65, C65M

3.6 KICK STARTER

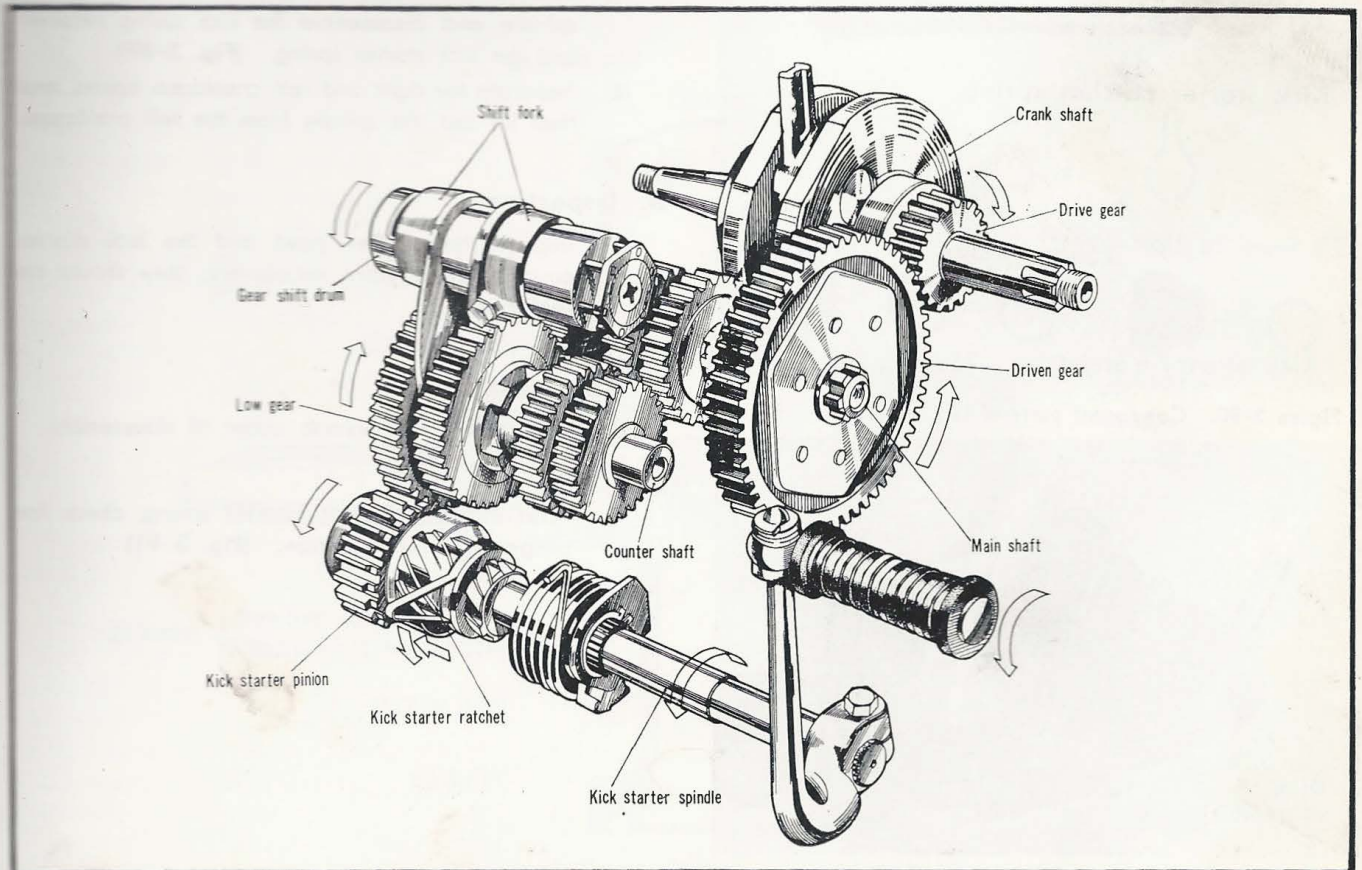

Figure 3-87. Kick starter functional diagram

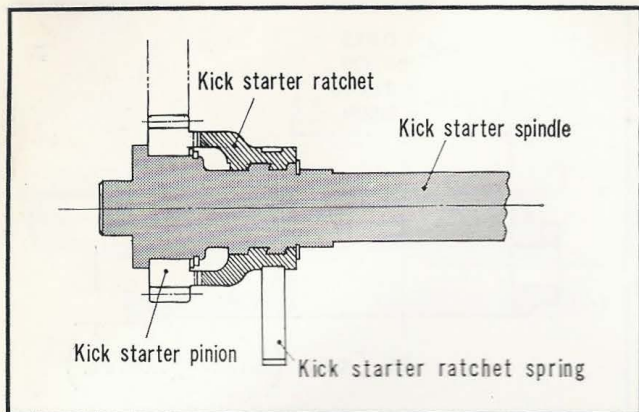

Figure 3-88. Kick starter construction

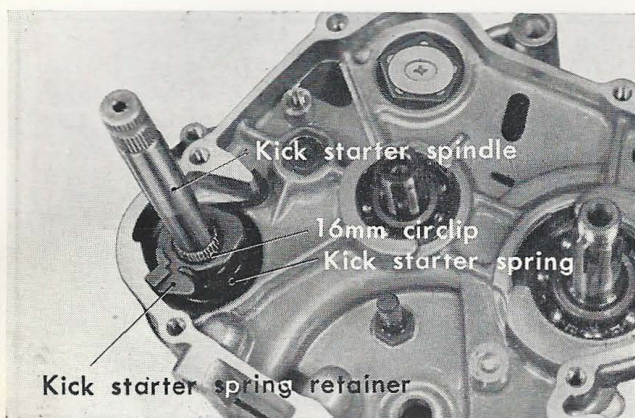

Figure 3-89. Removing kick starter

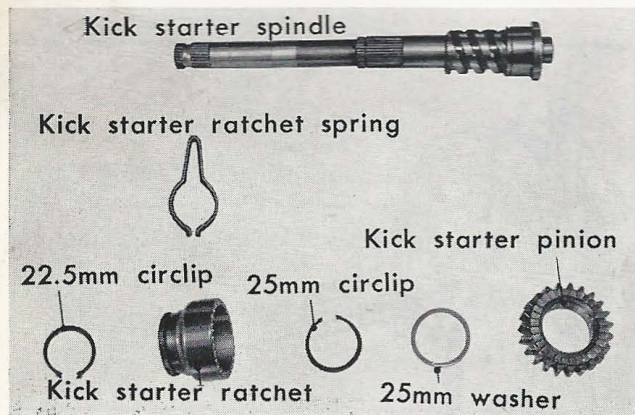

Figure 3-90. Component parts of kick starter

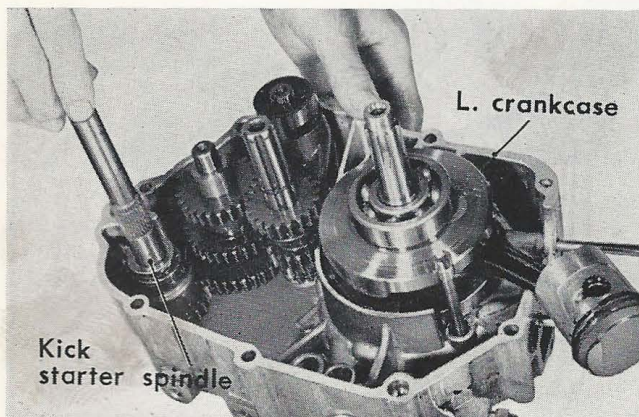

Figure 3-91. Installing kick starter spindle

As the kick starter is depressed, the kick starter spindle rotates and the ratchet, due to it being held against the ratchet spindle in the direction of rotation, moves in the direction of the arrow by following the spiral groove cut in the spindle and causes the kick starter pinion to mesh with the counter shaft low gear. The main shaft being engaged to the clutch center, transmits the kick starter torque to the engine crankshaft and turns over the engine. When the engine starts, the rotating speed of the pinion exceeds the spindle speed, the ratchet due to the rotation of the pinion, rotates in the left hand direction in respect to the spindle and is made to disengage from the pinion due to the action of the set spring and the left hand screw.

As the spindle returns to the original position by the action of the kick starter spring, the ratchet disengages from the pinion and returns to the position for the next kick cycle. (Fig. 3-89)

a. Disassembly

- (1) Remove the clutch unit.
- (2) Remove flywheel and stator assembly.
- (3) Remove the primary driven gear.
- (4) Remove the gear shift spindle.
- (5) Remove the 16mm circlip from the kick starter spindle and disassemble the kick spring retainer and the kick starter spring. (Fig. 3-89)
- (6) Separate the right and left crankcase halves and then lift out the spindle from the left crankcase.

b. Inspection

- (1) Inspect the ratchet pawl and the kick starter pinion teeth, if worn excessively, they should be replaced.

c. Reassembly

- (1) Assemble in the reverse order of disassembly.

(Note)

After installing the kick starter spring, check for proper kick return action. (Fig. 3-91)

3.7 CARBURETOR (C50, C50H, C65, C65M)

The function of the carburetor is to atomize the fuel and supply a fuel mixture of proper fuel air ratio. Further, in order to maintain a constant performance, the following components are made wear resistant. The carburetor has the following features. (Fig. 3-92)

- (1) By using a piston type of a throttle valve, a high power output, good acceleration and economy are obtained over a wide speed range.
- (2) Starting in low temperature is facilitated due to the use of the choke valve which incorporates a relief valve.
- (3) The use of the oval bore, affords good riding and acceleration, and the top speed is readily obtainable.

Design and Function

- Floor.....Maintains the fuel at a constant level.
- Floor chamber...Reservoir to store the fuel temporarily and permits it to be supplied.
- Cable adjuster...Regulates the length of the throttle cable.
- Main jetMeters the rate of fuel flow during maximum power output.
- Throttle valve...Regulates the amount of air fuel mixture entering the cylinder.
- Air screw.....Regulates the amount of air mixing with the fuel.

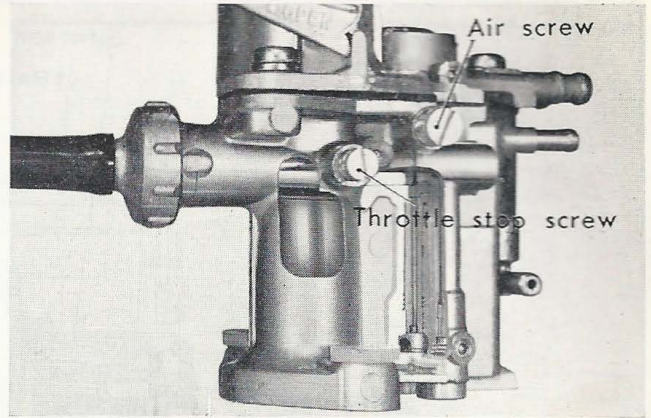

Figure 3-92. Carburetor (From cut-away carburetor)

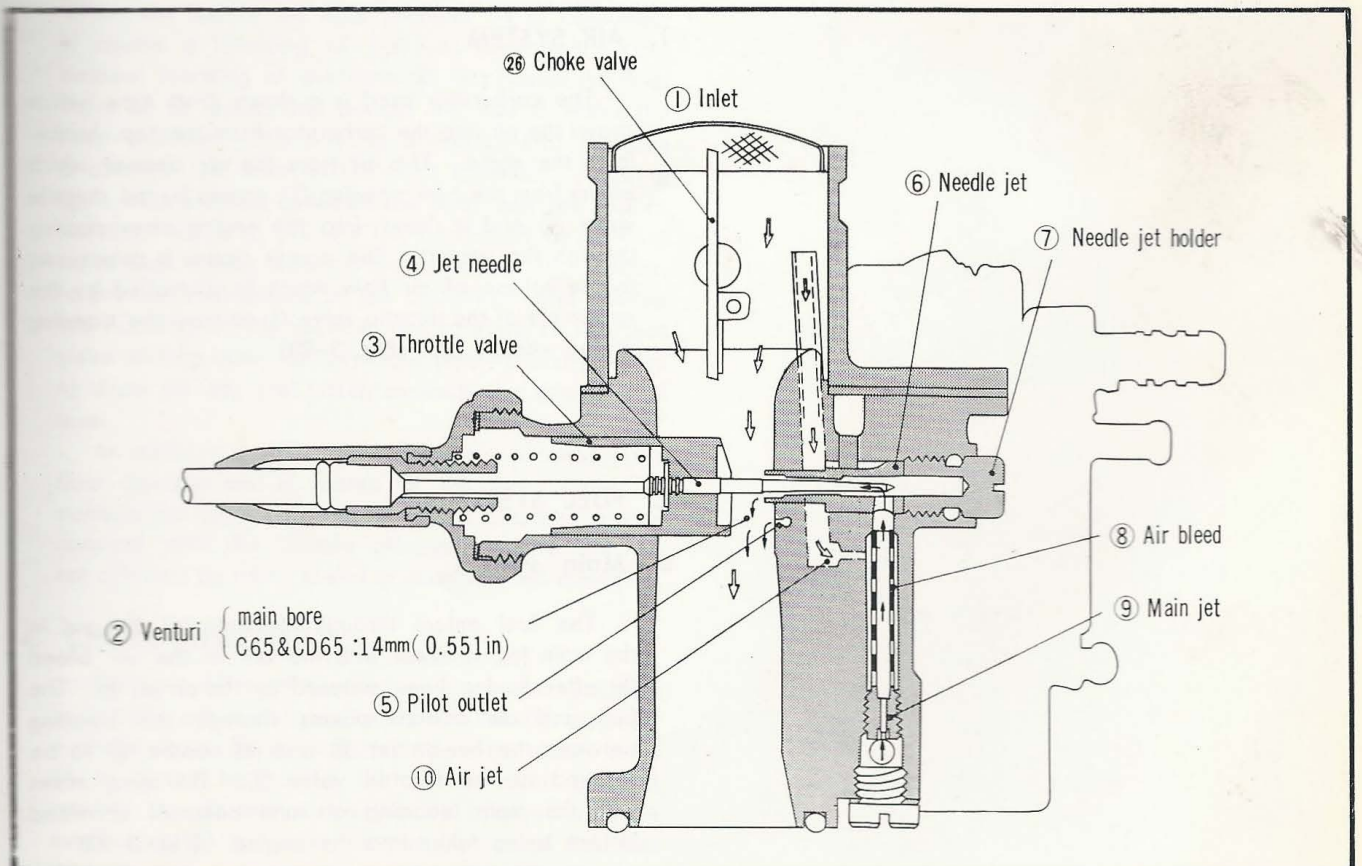

Figure 3-93. Carburetor sectional diagram

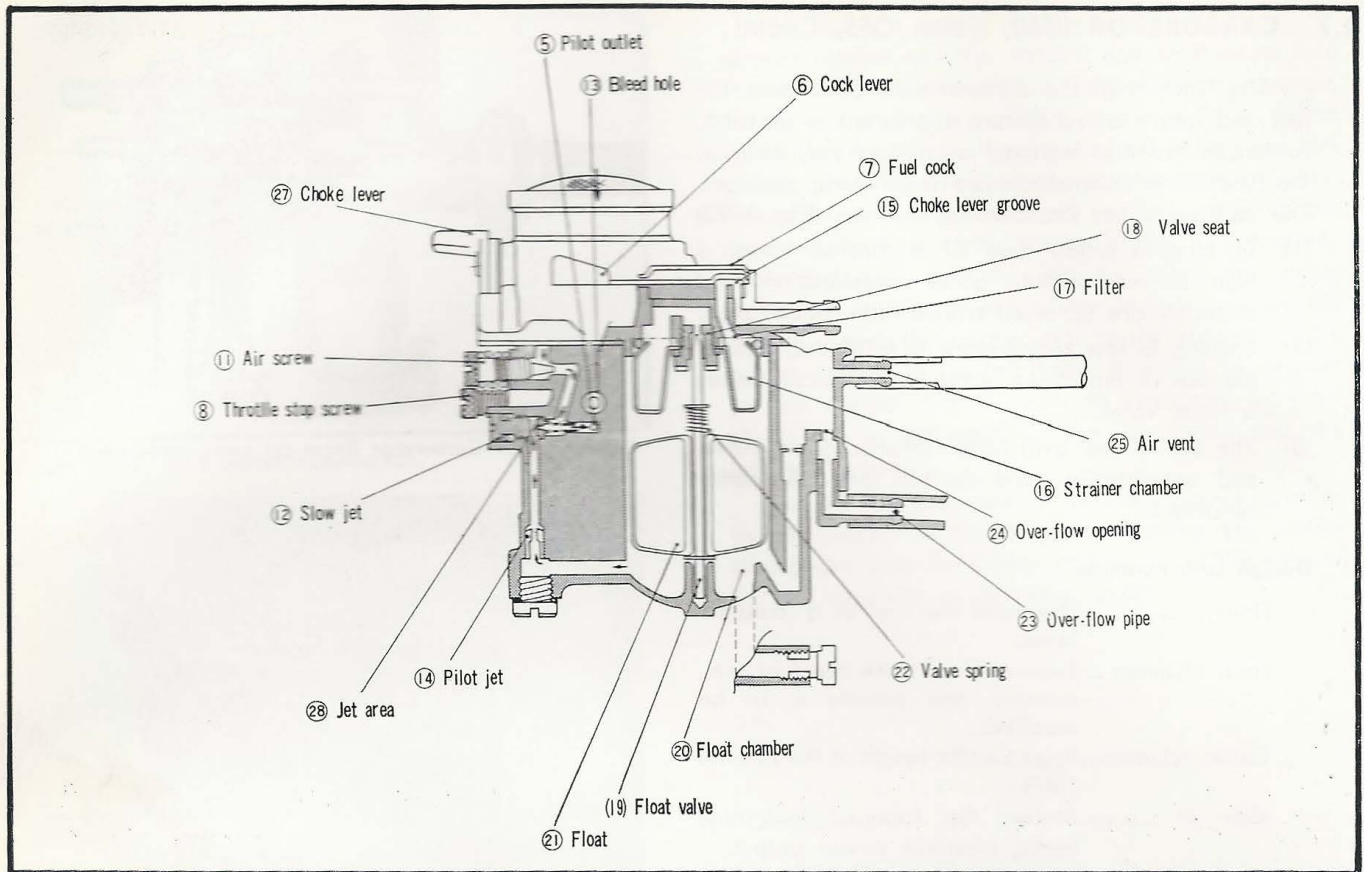

Figure 3-94. Carburetor cross sectional diagram

1. AIR SYSTEM

The carburetor used is a down draft type which draws the air into the carburetor from the top, henceforth the name. The air from the air cleaner which enters from the inlet opening ①, passes by the throttle valve ③ and is drawn into the engine after passing through the venturi. The power output is determined by the volume of air flow which is controlled by the movement of the throttle valve ③ to vary the opening of the venturi ②. (Fig. 3-93)

2. FUEL SYSTEM

a. Main system

The fuel enters through the main jet ⑨, and in the main jet, it mixes with the air in the air bleed ⑧ after having been metered by the air jet ⑩. The fuel and air mixture passes through the opening between the needle jet ⑥ and jet needle ④ to be sprayed at the throttle valve ③. The spray mixes with the main incoming air and becomes atomized before being taken into the engine. (Fig. 3-93)

b. Slow system

The air which enters from the inlet opening ① passes around the outside of the air screw ⑪ where it is metered and then enters the bleed hole ⑬ of the slow jet ⑫. On the other hand, the fuel from the float chamber ⑳ after being metered by the pilot jet ④ and metered again at the jet area ⑳ of the slow jet ⑫, mixes with the air from the bleed hole ⑬ within the slow jet and is sprayed out at the bottom of the throttle valve ③ from the pilot outlet ⑤, to mix with the main flow of air from the carburetor air inlet ① and is then taken into the engine.

3. FLOAT CHAMBER

It is necessary for the carburetor to supply the proper fuel mixture for the respective throttle opening and engine speed; in order to do this, the fuel level must be maintained at a constant level. It is the function of the float chamber to perform this task.

The DP type carburetor incorporates a filter in the float chamber to prevent entry of dust.

The fuel from the tank flows through the groove ⑮ in the fuel cock, enters the strainer compartment ⑯ where the dust and foreign matters in the fuel are allowed to settle, passes through the filter ⑰ and then enters the float chamber ⑳. As the fuel level in the float chamber rises, the float ㉒ becomes buoyant and applies pressure against the valve spring ㉓ to override it and then forces the float valve ⑲ against the valve seat ⑱ to stop the flow of the fuel. When the fuel in the float chamber ⑳ is consumed, it causes a lowering of the fuel level and a consequent lowering of the float ㉒, this causes the float valve ⑲ to unseat and permits the fuel to enter the float chamber. This process is repeated to maintain a constant fuel level in the float chamber. A spring ㉔ is incorporated between the float and the top of the float valve to prevent the oscillation of the float valve and reduce wear to the valve seat ⑱. Further, to prevent overflowing of the carburetor and causing the flooding of the cylinder due to tilting or the float valve sticking open, an overflow pipe is incorporated to drain off any fuel which exceeds the critical fuel level.

In addition a static air vent tube is located in the float chamber and is vented at the front cover to maintain the air pressure in the float chamber always constant with the outside atmosphere and which is not affected by riding speed or outside wind condition.

4. CHOKE (STARTING)

During cold weather starting, it may be necessary to initially use a rich fuel mixture. For this purpose, a choke valve ㉖ is incorporated. The choke valve ㉖ is closed by raising the choke lever ㉗, this restricts the air and allows the fuel sprayed from the needle jet ⑥ to enter the engine as a rich fuel mixture.

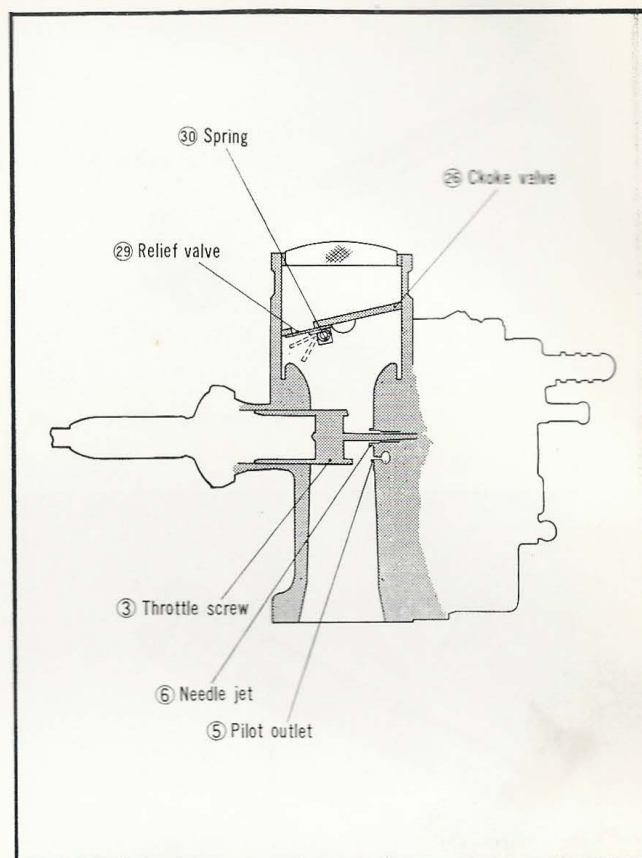

Figure 3-95. Carburetor cross sectional diagram

However, depending upon its usage, it may result in engine stalling or flooding. To counter this situation, a relief valve (29) is incorporated in the choke valve (26) to open or closes at a preset suction pressure, to produce a proper fuel air mixture for cold weather starting. It is therefore possible to close the choke valve completely during warm-up driving and then fully open the valve after warm-up. (Fig. 3-95)

5. FUNCTION OF THE RESPECTIVE COMPONENTS

a. Main jet

It restricts the fuel flow during full throttle condition (top speed) to provide a proper fuel mixture. Not only does it function at top speed but also is effective to a certain degree at intermediate speed. The larger the main jet size number, greater will be the fuel flow and providing a richer fuel mixture. (Fig. 3-96)

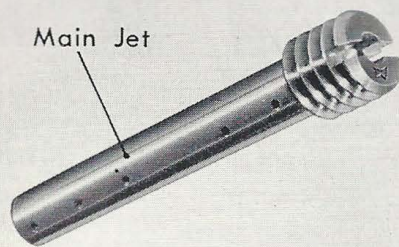

Figure 3-96. Main jet

b. Air jet

During full throttle opening, the fuel mixture at high engine speed will become rich and at slow engine speed the mixture becomes lean. To prevent such a condition, air is bled into the main jet. The function of the air jet is to restrict the amount of air.

As the air jet is made larger, the amount of air is increased, resulting in a lean fuel mixture, however, at the throttle opening, a high engine speed will provide a lean mixture with a smaller variation in fuel consumption between high and low engine speed. (Fig. 3-97)

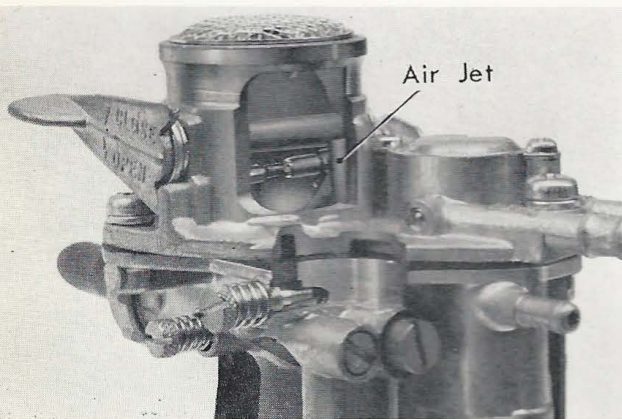

Figure 3-97. Air jet

c. Needle jet

During full or half throttle opening, the fuel which had been metered by the main jet is again metered by the needle jet. The adjustment is performed in conjunction with the jet needle which is explain in the following section. The needle hole is made exceptionally accurate. (Fig. 3-98)

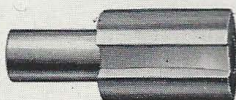

Figure 3-98. Needle jet

d. Jet needle

The jet needle in conjunction with the needle jet described earlier, regulates the fuel mixture at the intermediate throttle opening (principally between $\frac{1}{4}$ to $\frac{1}{2}$ throttle opening). The long tapered jet needle is located centrally within the center hole of the throttle valve and with the tapered end inserted into the needle jet. The vertical movement of the throttle valve to which the jet needle is attached controls the flow of the fuel in respect to the throttle opening to afford a correct fuel mixture ratio. There are five needle clip grooves (which are counted from the top) to regulate the richness of the fuel mixture. The fuel mixture becomes richer as the clip is moved progressively from the No. 1 groove to the No. 5 groove. (Fig. 3-99)

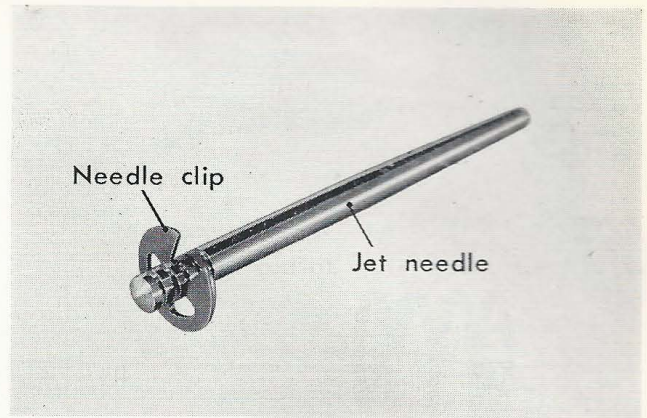

Figure 3-99. Jet needle

e. Throttle valve

The function of the throttle valve is to control the amount of air taken into the engine which serves to increase the engine RPM and the power output, and in addition, performs the important function of controlling the fuel air mixture. (Fig. 3-100)

The throttle valve is cut-away on the air inlet side. By changing the size of the cut-away (designated by cut-away No.) the pressure actuating the needle valve can be altered to change the amount of fuel flow and causes a change to the fuel mixture. The valve with a larger cut-away number will produce a leaner fuel mixture. However, the range of its effectiveness is mainly at low speed from idling speed to approximately $\frac{1}{4}$ throttle opening. It has no effect beyond $\frac{1}{2}$ throttle opening.

The throttle valve is normally operated by the throttle cable attached to the top of the carburetor. A throttle stop screw keeps the throttle valve in the idle position.

Turning the stop screw in will cause the throttle valve to rise, and backing off on the stop screw will lower the throttle valve.

(Caution)

The throttle valve guide groove serves as a junction for the throttle cable and the throttle valve and also to maintain the throttle valve in the correct relative position within the carburetor, therefore, if it is reversed, the cut-away will be on the wrong side and will result in rich fuel mixture as well as causing insufficient engine speed.



Figure 3-100. Throttle valve

f. Slow jet

The slow jet regulates the fuel flow during idling and small throttle opening, and permits the air to enter through the air bleed to mix with the fuel for atomization.

The slow jet is similar to the main jet in that the larger the jet size number, the greater will be the fuel flow and consequently a richer fuel air mixture. (Fig. 3-101)

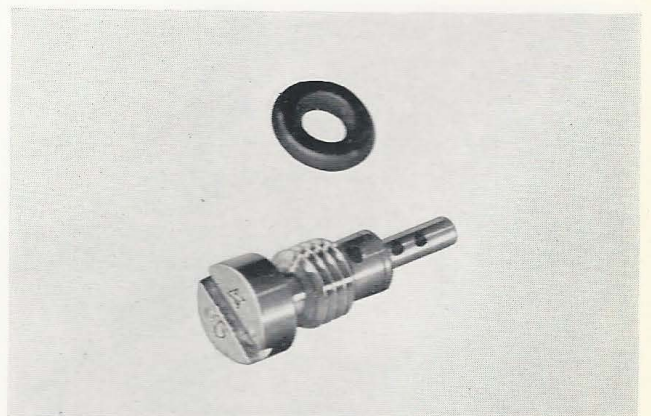

Figure 3-101. Slow jet

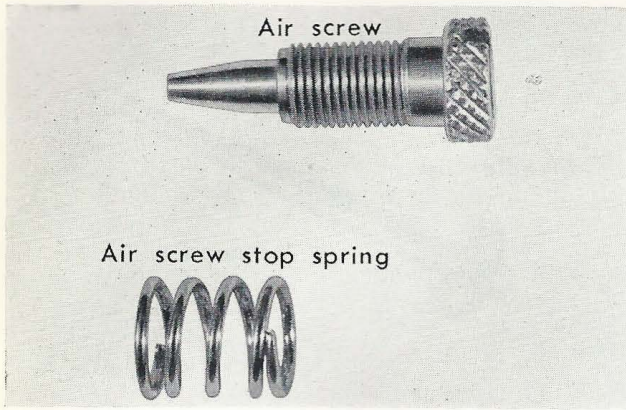

Figure 3-102. Air screw

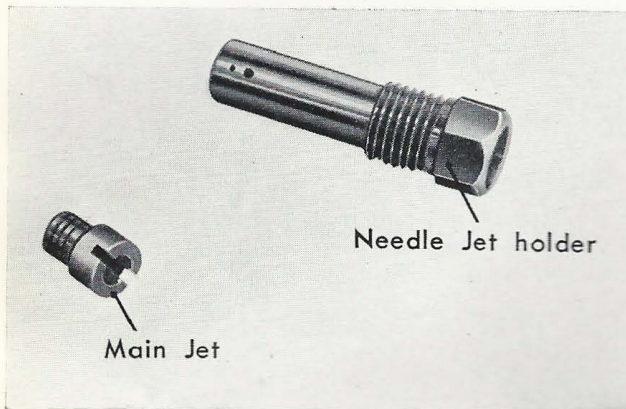

Figure 3-103. Main jet

g. Air screw

The air screw regulates the amount of air mixing with the fuel in the slow speed system by controlling the amount of pilot air mixing with the fuel which had entered from the slow jet. In this way, the proper fuel air mixture is maintained (Fig. 3-102)

Turning the air screw in will produce a rich fuel air mixture and backing off on the screw will result in a lean mixture.

6. ADJUSTING THE CARBURETOR

a. High speed adjustment

Whenever a higher speed can be obtained with the choke slightly closed, it is an indication that the carburetor is adjusted lean, therefore, the main jet should be progressively replaced with a jet of a larger size and retested to obtain the correct size.

(Note)

The main jet number sizes below #100 are 98, 95, 92, 90, and the sizes above #100 are 110, 115 and increases at an interval of 5. (Fig. 3-103)

If the speed drops when the choke valve is closed, it is an indication that the main jet is either of the correct size or too large. The determination is made by the following procedure.

○ The Correct Main Jet

After the main jet had been change to one of a smaller size, it is found that the speed decreases and upon closing the choke a small amount, the speed increases, it is an indication that the main jet which had been installed is too small in size. The main jet should be replaced again with the original main jet which can be assumed to be of the correct size.

○ Too Large a Main Jet

Replace the main jet progressively with one of a smaller size until the condition in the previous section occurs.

b. Adjusting the Intermediate Speed

The fuel mixture adjustment between the throttle opening $\frac{1}{8}$ to $\frac{3}{4}$ is accomplished mainly by selecting the steps on the needle jet and also by the cut-away on the throttle valve. However, it is not practical to adjust only the intermediate speed with the cut-away of the throttle valve since the cut-away effects the range of throttle between $\frac{1}{4}$ to $\frac{1}{16}$ opening. In the intermediate range, the jet needle should be in the lower position for good fuel economy provided that the acceleration is good:

(1) Jet Needle

- a. When excessive black exhaust smoke is evident during intermediate speed, it is an indication of too rich a fuel mixture and therefore, the jet needle should be lowered one step.
- b. If during acceleration or at intermediate speed, the engine sputters, misses or does not respond, the jet needle should be raised one step.

(2) Throttle valve cut-away. (Fig. 3-104)

The larger the number stamped on the cut-away, leaner will be the fuel mixture. When making the adjustment of the throttle valve, the slow speed should also be considered together with the intermediate speed since the effective range of the throttle is very broad.

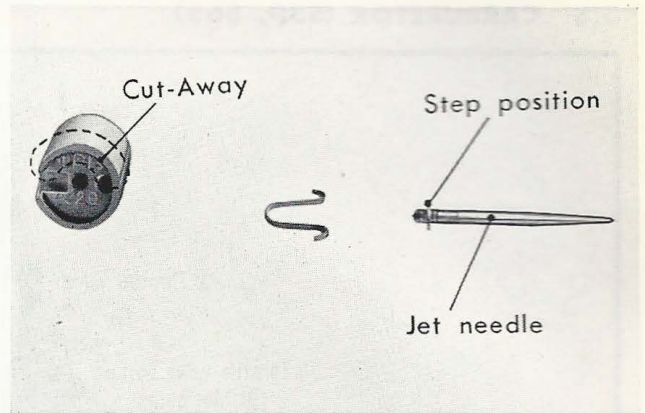

Figure 3-104. Jet needle and cut-away of the throttle valve

c. Adjusting the Slow Speed

The fuel mixture adjustment between idling and $\frac{1}{8}$ throttle opening is made by the air screw and the throttle valve cut-away.

(1) Air screw

The fuel mixture adjustment for idling is made by the air screw.

Turn to the right for a richer mixture. Turn to the left for a leaner mixture. The air screw not only affects the idling but also the slow speed, therefore, the fuel mixture should be adjusted with the throttle slightly opened to obtain a smooth operation.

(2) Throttle valve cut-away

There may be a case where the adjustment cannot be obtained by the air screw only, in the vicinity of $\frac{1}{8}$ throttle opening. In this case, if the fuel mixture is too rich, replace the cut-away with one of a larger number and if too lean, replace with one of a smaller number.

d. Adjusting the Idle (Fig. 3-105, 3-106)

The idling adjustment is performed by the throttle stop screw and the air screw in the following manner.

- (1) Adjust the idling speed to the standard 1200 RPM by the use of the throttle stop screw.
- (2) Next, turn the air screw slowly back and forth to the highest RPM.
- (3) Upon locating the point of highest RPM in (2) above, reset the engine speed to the standard RPM.
- (4) Rework the air screw to assure that it is set at the proper setting.
- (5) If any change exist, repeat (3) (4) above. The check should be made between $\frac{1}{8}$ to $1\frac{1}{2}$ turn of the air screw.

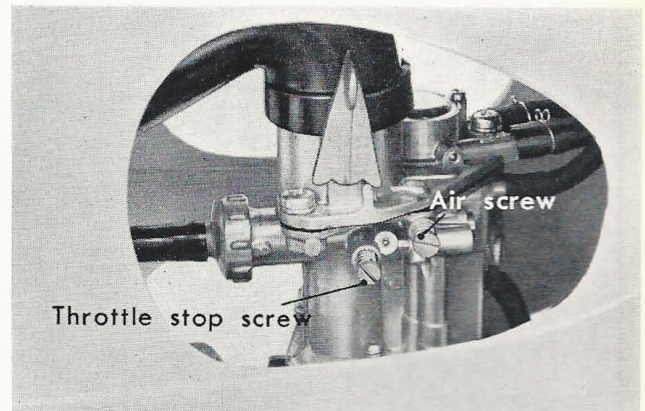

Figure 3-105. Idle adjustment

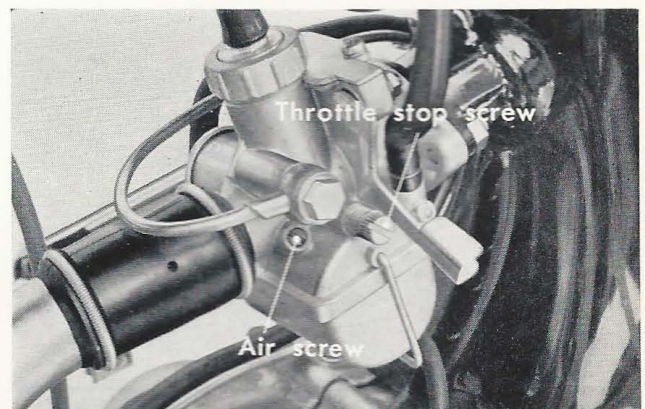

Figure 3-106. Idle adjustment (S50, S65)

3.8 CARBURETOR (S50, S65)

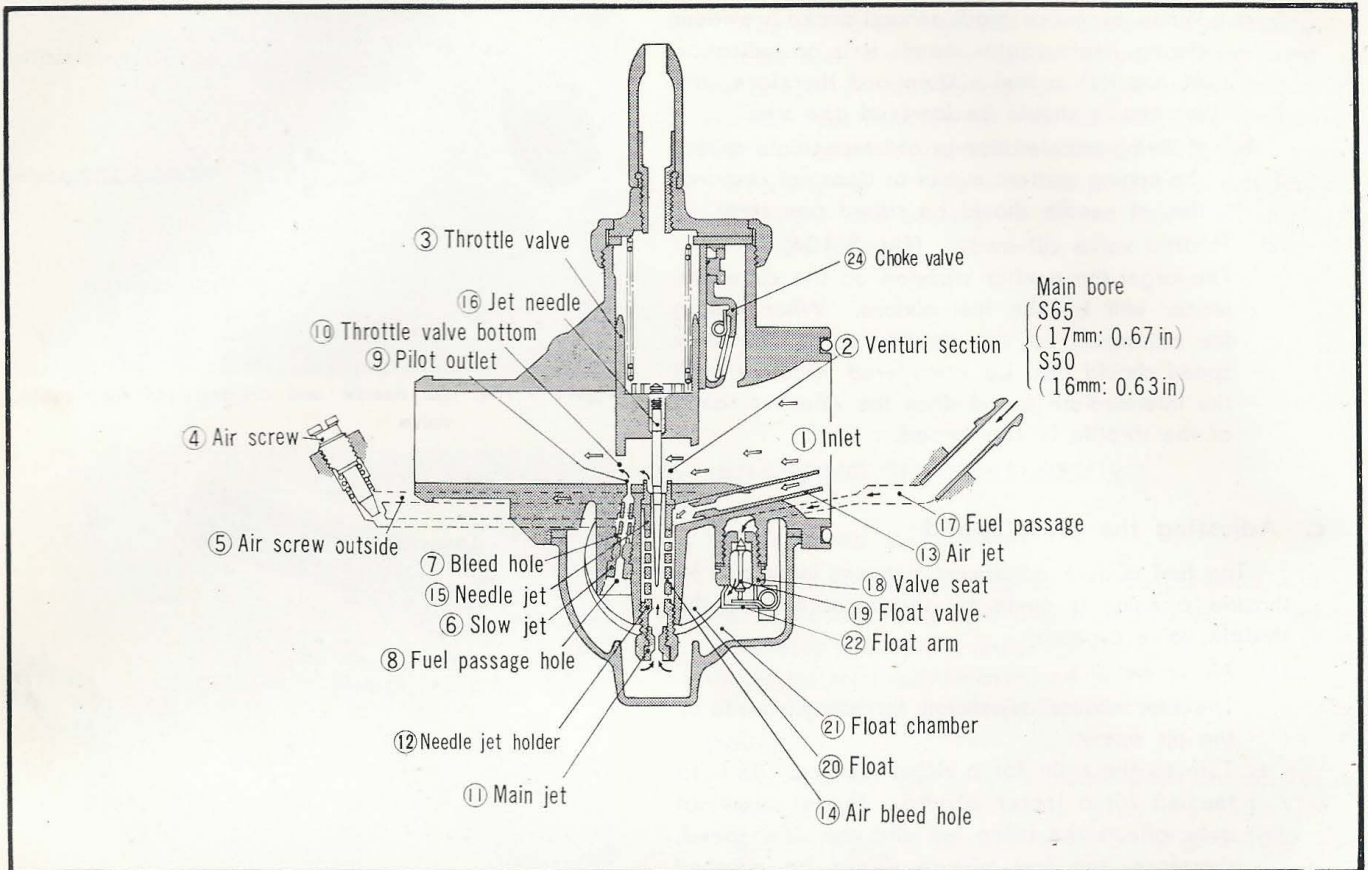

Figure 3-107. Carburetor cross sectional diagram

1. AIR FLOW

The air which passes through the air cleaner enters from inlet opening ①, passes under throttle valve ③ (main bore ②) and taken into the inlet side of the engine. The power output is determined by the volume of air taken into the engine. This necessary air flow is controlled by the vertical movement of the throttle valve which varies the area of the main bore ②. (Fig. 3-107)

2. FUEL FLOW

The air which flow through the main bore ② creates a low pressure directly under the throttle valve. It is here that the fuel outlets for both the main and slow systems are located. (Fig. 3-107)

a. Main System

The fuel passes through main jet ⑪ and enters the needle jet holder ⑫. The fuel mixes with the air taken in at air jet ⑬ and bled through air bleed hole ⑭. The fuel air mixture passes between needle jet ⑮ and jet needle ⑯, and discharges in a spray below the throttle valve ③. The fuel is atomized and mixed with the main air stream and is taken into the engine. (Fig. 3-107).

b. Slow System

The air which enters through air inlet ① passes around air screw ④ where it is metered and then mixed with the fuel from the fuel passage hole ⑤ and is discharged from pilot outlet ⑥ toward the throttle valve ③ as a fuel air mixture and finally mixes with the main air stream before entering the engine.

3. FLOAT CHAMBER

For S50 and S65, the fuel from the tank enters fuel passage ⑰, passes by valve seat ⑱, float valve ⑲ and enters float chamber ⑳. As the fuel fills the float chamber, the float ⑳ rises and forces the float valve against the valve seat with the float arm ㉑ to shut off the fuel flow into the float chamber. As the fuel in the float chamber is consumed and the fuel level drops, the float also lowers with the fuel level and allows the float valve to unseat from the valve seat, permitting the fuel to enter the float chamber. This cycle is repeated to maintain a constant fuel level.

A spring is incorporated in the float valve ⑲ where the float arm ㉑ make contact, for the purpose of absorbing the shock and preventing wear to the valve and seat caused by the fluctuation of the float when driving over rough road and in addition, it serves to maintain a constant full level in the float chamber.

Overflow pipe

If any foreign object should get stuck in between the float valve and seat and causes the fuel to overflow out of the slow jet or the needle jet, the fuel will enter the engine and dilutes the oil. To prevent such an occurrence, an overflow pipe ㉒ is incorporated into the float chamber ㉑. The outlet of the overflow pipe ㉒ is higher than the normal fuel level and therefore, has no effect, but under overflow condition, the fuel level rises and the overflow fuel is drained outside. (Fig. 3-108)

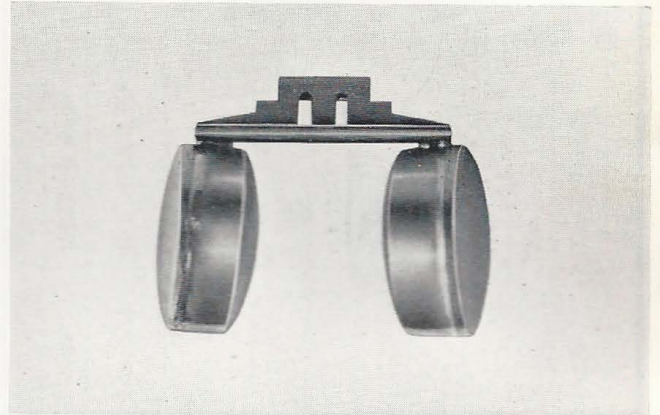

Figure 3-108. Float (S65)

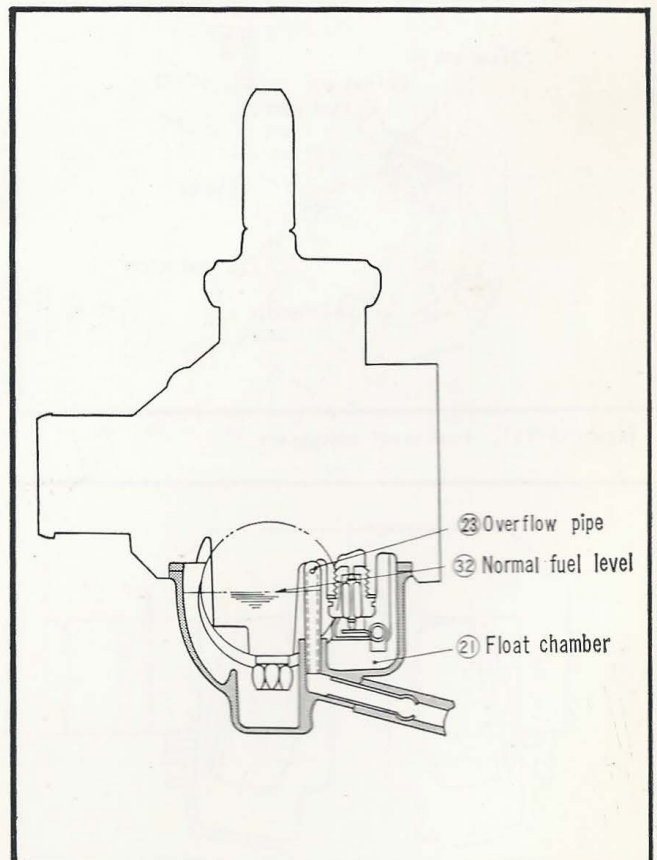

Figure 3-109. Float chamber

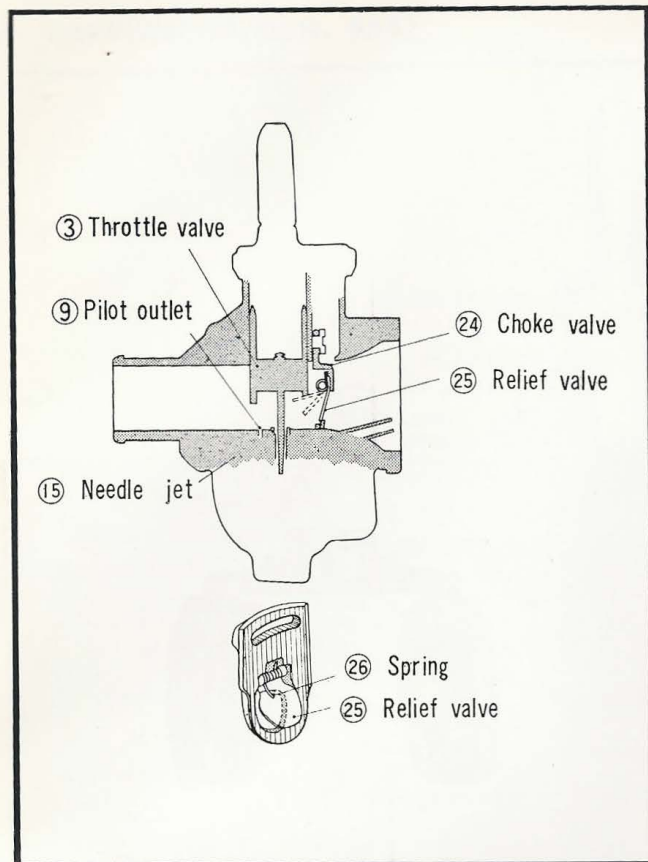

Figure 3-110. Choke

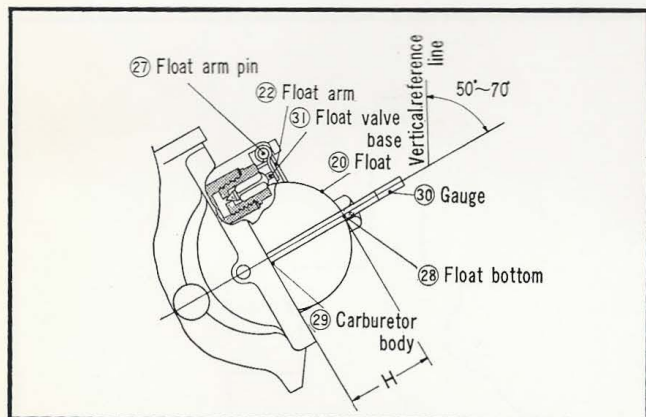

Figure 3-111. Fuel level adjustment

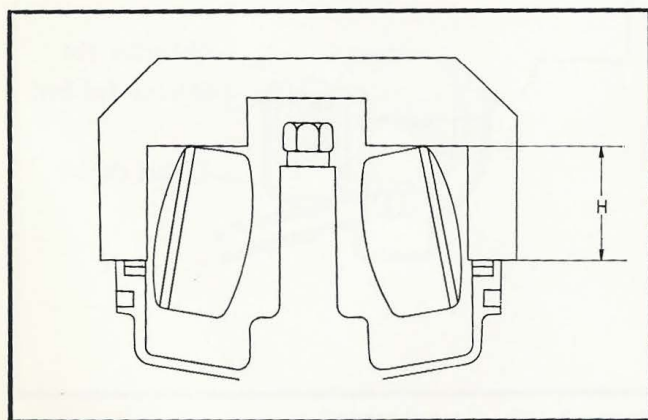

Figure 3-112. Fuel level gauge

1. CHOKE (STARTING SYSTEM)

Since it is necessary to provide a rich mixture for a short period during cold weather starting, choke ⑲ is incorporated. By raising the choke lever to the full close position, the choke valve ⑲ can be completely closed. A relief valve ⑳ is installed on the choke valve and kept in the closed position by the spring ㉑. When the kick pedal is kicked with the throttle valve ③ opened approximately $\frac{1}{4}$, the suction pressure causes the fuel to be discharged from the pilot outlet ⑨ and the needle jet ⑮, and at the same time, the suction pressure causes the relief valve to open a proper amount, permitting the air to enter and produces a fuel mixture which is ideal for starting.

After the engine starts, the suction pressure increases, opening the relief valve wider and furnishes the cold engine with the proper starting fuel mixture. In this way, the opening of the throttle valve causes a corresponding opening of the relief valve and permits the warming up of the engine without manipulating the choke lever. When the engine has warmed up, merely position the choke valve to the fully open position. (Fig. 3-110)

5. ADJUSTING THE FUEL LEVEL

It is difficult to directly measure the fuel level, therefore, the fuel is determined by measuring the height (H) of the float. (Fig. 3-111, 3-112)

- (1) Position the carburetor as shown in Fig. 3-111 with the float arm pin ㉓ toward the top and the float ㉖ at the bottom and tilt the carburetor to the point where the float arm ㉔ is about to break contact with the float valve base. This should occur when the carburetor is tilted approximately 70° or at any point between 50° to 70° . That is, the float arm should be at a point where the base of the valve is not compressed.
- (2) In this position, the float bottom ㉘ is measured from the carburetor body ㉙ with the gauge ㉗ to determine the height (H). The tolerance of the float position is 1mm (0.040 in) both ways. In other words, the gauge should not press the float more than 1mm, nor should there be clearance greater than 1mm between the gauge and the float. Care should be exercised in making the measurement since the base of the valve is spring loaded and can be compressed into the valve in which case, the true closing point of the valve cannot be determined.

6. CARBURETOR SETTING TABLE

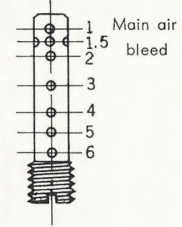
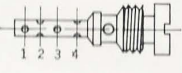
Model Carburetor type	C65 1000-112 (1000-113)	C65M 1000-115	C50 1000-110 (1000-145)	C50M 1000-111	S65 PW16FA6 (CF130) PW16FA10 (CYFF130)	S50 PW16FA11	
Setting mark	65H (Y65H)	65MB	C50C	50MB	17-B	K	
Throttle bore	13φ (0.512 in.)	13φ	13φ	13φ	16mm (0.630 in.)	16mm (0.630 in.)	
Venturi bore	14φ (0.551)	14φ	13φ	13φ	17mm (0.670 in.) equiv.	16mm (0.630 in.) equiv.	
Main jet	#72	#72	#70	#72	#85	#78	
Air jet	#150	#150	#150	#150	#150	#120	
 <div style="display: flex; flex-direction: column; align-items: center;"> <div style="margin-bottom: 5px;">Main air bleed</div> <div style="margin-bottom: 5px;">1</div> <div style="margin-bottom: 5px;">1.5</div> <div style="margin-bottom: 5px;">2</div> <div style="margin-bottom: 5px;">3</div> <div style="margin-bottom: 5px;">4</div> <div style="margin-bottom: 5px;">5</div> <div style="margin-bottom: 5px;">6</div> </div>	AB1	0.4φ × 2 (0.0157 in.)	0.5φ × 2	0.4φ × 2	0.5φ × 2	0.5mm (0.0197 in.) × 4	0.9mm (0.0354 in.) × 4
	1.5	0.4φ × 2	0.4φ × 2		0.4φ × 2		
	2	0.4φ × 2	0.4φ × 2	0.4φ × 2	0.4φ × 2	0.9mm (0.0354 in.) × 2	0.6mm (0.0236 in.) × 2
	3	0.4φ × 2	0.4φ × 2	0.4φ × 2	0.4φ × 2	—	0.6mm (0.0236 in.) × 2
	4	0.4φ × 2	0.4φ × 2	0.4φ × 2	0.4φ × 2	0.5mm (0.0197 in.) × 2	0.6mm (0.0236 in.) × 2
	5	0.4φ × 2	0.4φ × 2			0.5mm (0.0197 in.) × 2	0.6mm (0.0236 in.) × 2
	6	0.4φ × 2	0.4φ × 2	0.4φ × 2	0.4φ × 2		
Needle jet	3.0 × 2.8mm (0.118 × 0.110 in.) 3φ × 28 recess	3φ × 2.8	3φ × 2.5	3φ × 2.5	2.6 mm (0.1023 in.) [3.4 (0.134 in.) recess]	2.6 mm (0.1023 in.) [3.4 (0.134 in.) recess]	
Jet needle	13243-3 stage	13243-3 stage	13239-3 stage	13239-3 stage	16305 3 stage	16232 3 stage	
Cut-away (throttle valve)	#2.0 [1.2 × 0.15] (0.047 × 0.006 in.) 2.0 (1.2φ × 0.15)	#2.0 (1.2 × 0.15)	#2.0 (1.2φ × 0.15)	#2.0 (1.2 × 0.15)	#1.5 [1.2 × 0.3] (0.047 × 0.012 in.)	#1.5 [1.2 × 0.3] (0.047 × 0.012 in.)	
Air screw	1¼ ~ 1/8	1¼ ~ 1/8	1¼ ± 1/8	1¼ ± 1/8	1½ ~ 1/8	1½ ~ 1/8	
Slow jet	#35	#35	#35	#35	#38	#35	
	1	0.8mm (0.315 in.) × 2 0.8φ × 2	0.9φ × 2	0.8φ × 2	0.9φ × 2	0.7mm (0.0276 in.) × 2	0.8mm (0.0315 in.) × 2
	2	0.8mm (0.315 in.) × 2 0.8φ × 2	0.8φ × 2	0.8φ × 2	0.8φ × 2	0.7mm (0.0276 in.) × 2	0.8mm (0.0315 in.) × 2
	3	0.8mm (0.315 in.) × 2 0.8φ × 2	0.9φ × 2	0.8φ × 2	0.9φ × 2	0.7mm (0.0276 in.) × 2	0.7mm (0.0276 in.) × 2
	4	0.8mm (0.315 in.) × 2 0.8φ × 2	0.8φ × 2	0.8φ × 2	0.8φ × 2	0.7mm (0.0276 in.) × 2	0.7mm (0.0276 in.) × 2
Valve seat	1.2mm (0.0473 in.) 1.2φ	1.2φ	1.2φ	1.2φ	1.0mm (0.0394 in.)	1.0mm (0.0394 in.)	
Pilot jet	#35	#35	#35	#35	—	—	
Pilot outlet	0.9mm (0.0354 in.) P=5.0	0.9φ P=5.0	0.9φ P=5.0	0.9φ P=5.0	1.0 mm (0.0394 in.) P=5.5	1.0 mm (0.0394 in.) P=5.5	
Fuel level (actual fuel height)	17.5mm (0.689 in.) 17.5	17.5	15.5	15.5	19.5 mm (0.768 in.) Height of float	19.5 mm (0.768 in.) Height of float	

Setting specifications

4. FRAME

4.1 HANDLE

1. HANDLE CONSTRUCTION

Steering Handle

The steering handle unit is made of pressed sheet steel with a continuous steel tube grip welded for reinforcement; the handle on the S50 and S65 is of semi-raised type pipe handle.

Soft rubber cushions are installed at the mounting of the steering handle to prevent the engine vibration from being transmitted to the rider's hand. A steering handle lower cover is newly installed to provide a pleasing overall design.

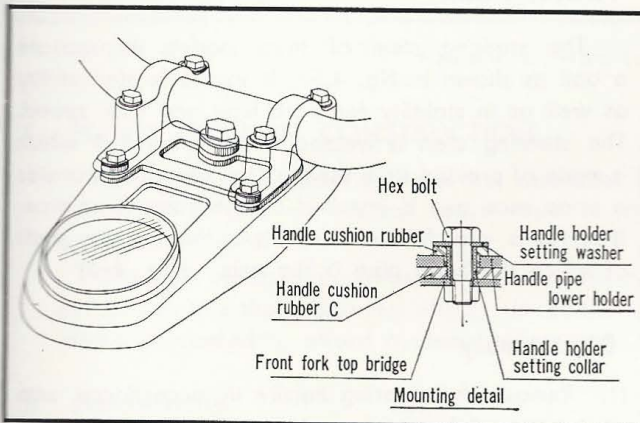

Figure 4-2A. Handle rubber mount (S50, C65)

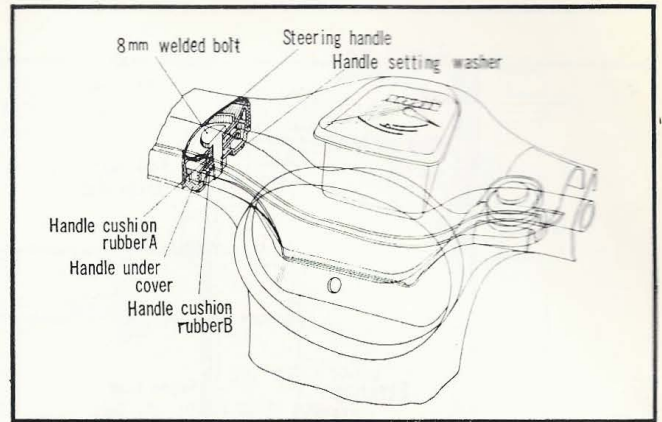

Figure 4-1. Handle rubber mount (C50, C50M)

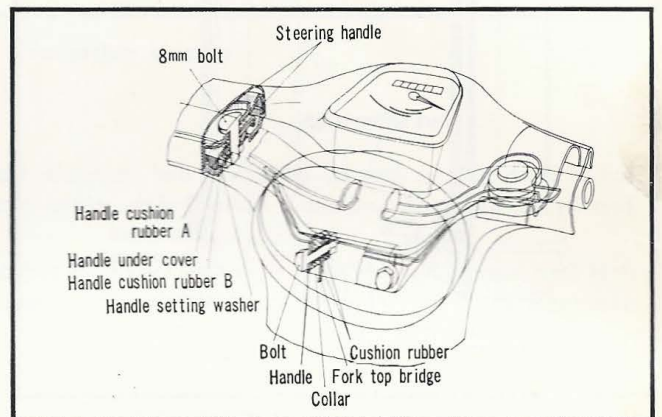

Figure 4-2B. Handle rubber mount (C65, C65M)

a. Disassembly

- (1) Remove the front cover.
- (2) Remove the headlight assembly and disconnect all electrical leads. (Fig. 4-3)
- (3) Uncouple the speedometer cable and disconnect the front brake cable.
- (4) Disconnect the throttle cable by removing the carburetor cap and disengage the cable end from the throttle valve. (Fig. 4-3)
- (5) Loosen the two 8mm hex nuts and remove the handle together with the cables and electrical leads.

For models S50 and S65, loosen the four hex bolts, remove the upper holder, and then remove the handle.

b. Inspection

- (1) Inspect the throttle, clutch and front brake cables for damage and breakage on both the inner cable and outer casing, and also for proper operation; apply grease before installation.
- (2) Check the throttle grip pipe for proper operation.
- (2) Check the handle levers for proper operation.
- (4) Inspect the handle pipe for bend and twist.
- (5) Check all switches for proper function and the electrical leads for damaged covering.

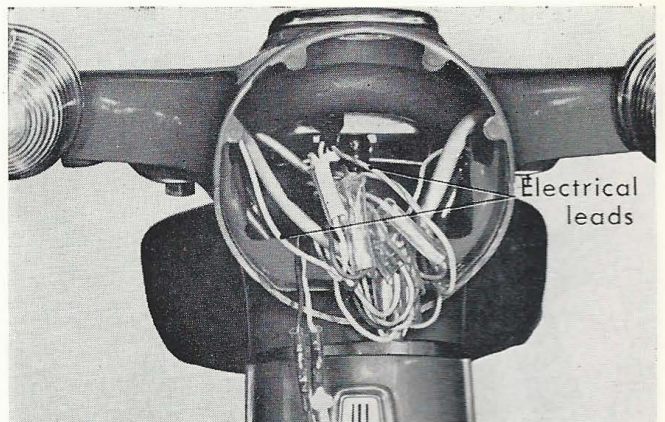

Figure 4-3. Disconnect electrical lead



Figure 4-4. Disconnect cable from throttle valve

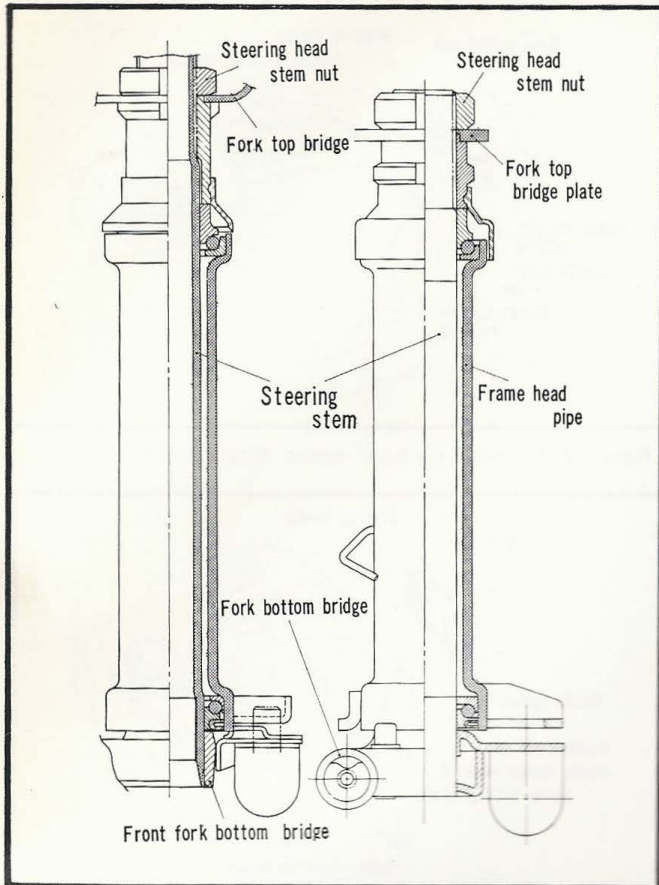

Figure 4-5. Steering stem sectional diagram (left C50, C65, right S65)

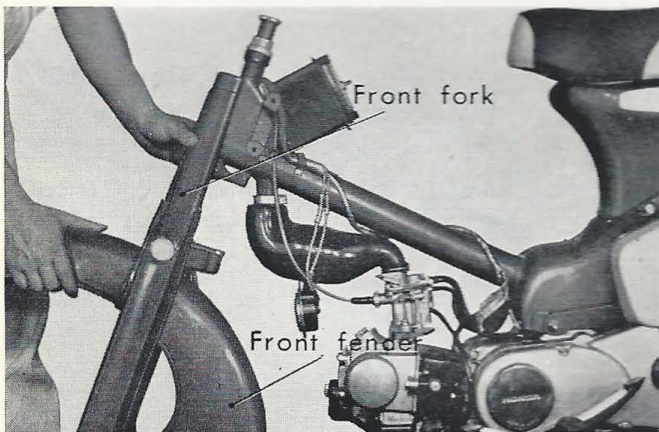

Figure 4-6. Removing front fork

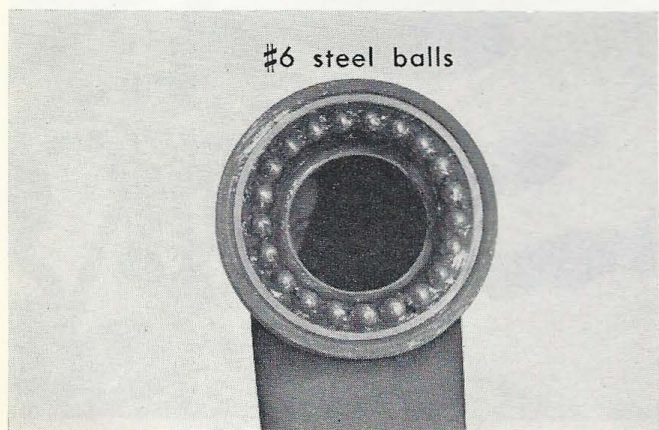

Figure 4-7. Steel balls

c. Reassembly

- (1) Re-install the wires, speedometer and leads on the specified locations and fix in place with handle fixing bolts and nuts.
- (2) Re-install the front brake cable, speedometer cable and throttle cable.
- (3) Reconnect all connectors from the electrical leads and re-install the headlight.

(Caution)

When installing the steering handle, care shall be taken not to pinch cables and leads.

2. FRONT FORK

The steering stem of these models incorporate a ball as shown in Fig. 4.5. It excels in steerability as well as in stability for both high and low speed. The steering stem is welded to the front fork which is made of pressed steel sheet. The stem incorporates a cone race and is installed on the frame head pipe. It serves a vital function since it is the rotating shaft of which the head pipe is the axis. (Fig. 4-5)

a. Disassembly

- (1) Remove the steering handle in accordance with section 4.1a.
- (2) Remove the headlight case.
- (3) Remove the front wheel in accordance with section 4.4a.
- (4) Remove the fork top bridge by unscrewing the steering head stem nut and the two 8mm bolts.
- (5) Unscrew the steering head top thread by using a hook spanner and slide the front fork out the bottom, (Fig. 4-6)

(Caution)

When removing the front fork care shall be taken not to drop and lose the #6 steel balls. (Fig. 4-7)

b. Inspection

- (1) Inspect the #6 steel balls for cracks and wear.
- (2) Inspect the steering stem for bend and twist.
- (3) Inspect the steering bottom and top cone races and ball races, for scratches, wear and streaks.

c. Reassembly

- (1) Wash the cone races, ball races and the steel balls, and pack with new grease. Use recommended fiber grease.

(Caution)

Care shall be taken not to over-torque the steering stem nut so as to cause heavy steering.

4.2 FRONT CUSHION

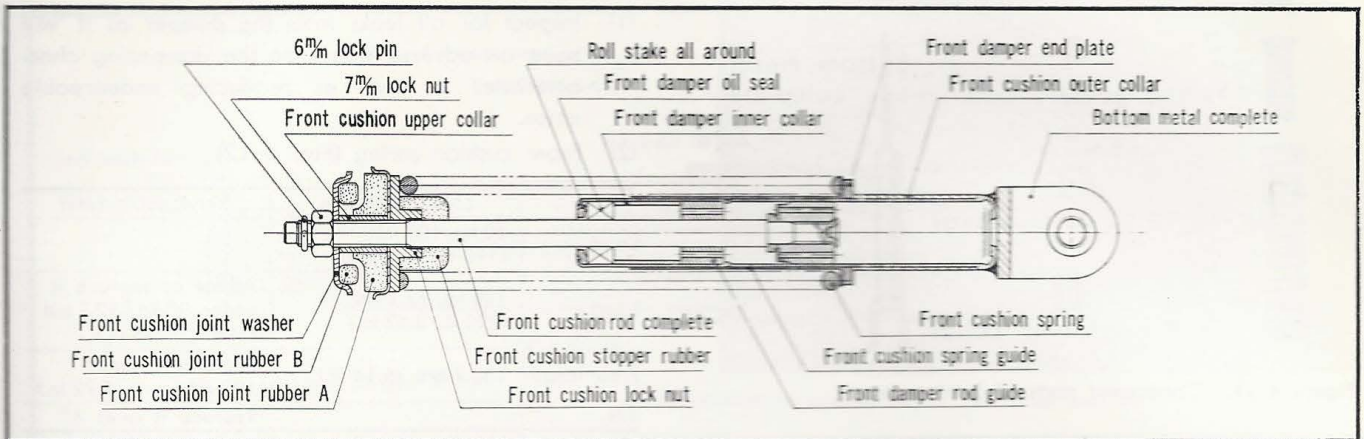

Figure 4-8. Front cushion cross section diagram

1. FRONT CUSHION CONSTRUCTION

The front wheel axle and axle nut assembles the cast aluminum hub consisting of two sets of 6202 radial ball bearings and an integral brake drum to the front brake panel which contains the brake shoes and speedometer gear.

The front cushion, in contrast to the previous type having an upper metal, is installed with a nut and lock pin to improve the cushioning effect. In addition, the upper bolt which had been torqued from the front fork side is eliminated to afford a clean appearance.

a. Disassembly

- (1) Remove the front wheel in accordance with section 4.4a.
- (2) Remove the 6 mm lock pin and 7 mm lock nut, and then the front cushion joint washer and the joint rubber A can both be removed. Next, by removing the front arm pivot bolt, and 8mm X 42, hex bolt the front cushion and the front suspension arm may be removed together from the front fork.
- (3) Remove the 8 mm hex nut and then by pulling out the 8 mm hex bolt, the front arm rebound stopper may be removed from the front fork.
- (4) By removing the 8 mm hex nut and the front cushion lower bolt; the front cushion and the front suspension arm may be separated.

(Caution)

- a. When separating the front suspension arm from the front cushion, care should be taken to prevent the front cushion lower dust seal cap, dust seal and distance collar from dropping.
- b. Remove the pivot dust seal by unlocking the staking and remove the dust seal and pivot collar. (Fig. 4-10)

- (5) The front cushion disassembly can be performed by removing the front cushion lock nut and then removing the front cushion spring.

(Caution)

The front damper bottom metal should not be disassembled as it requires special tools and the component parts are not sold individually.

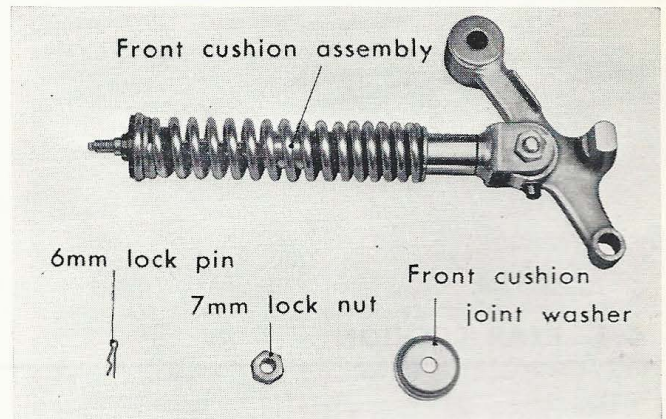

Figure 4-9. Front cushion

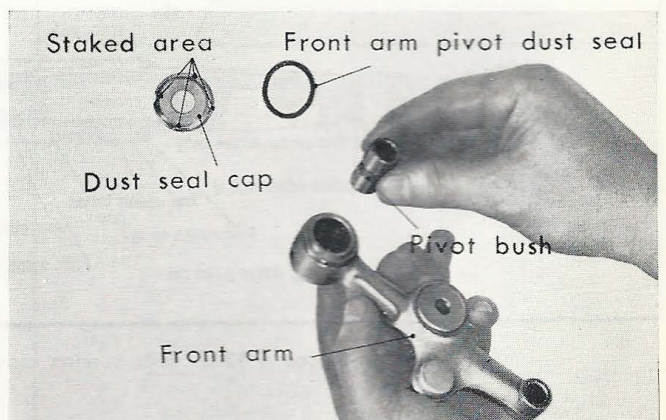

Figure 4-10. Staking the pivot dust seal cap

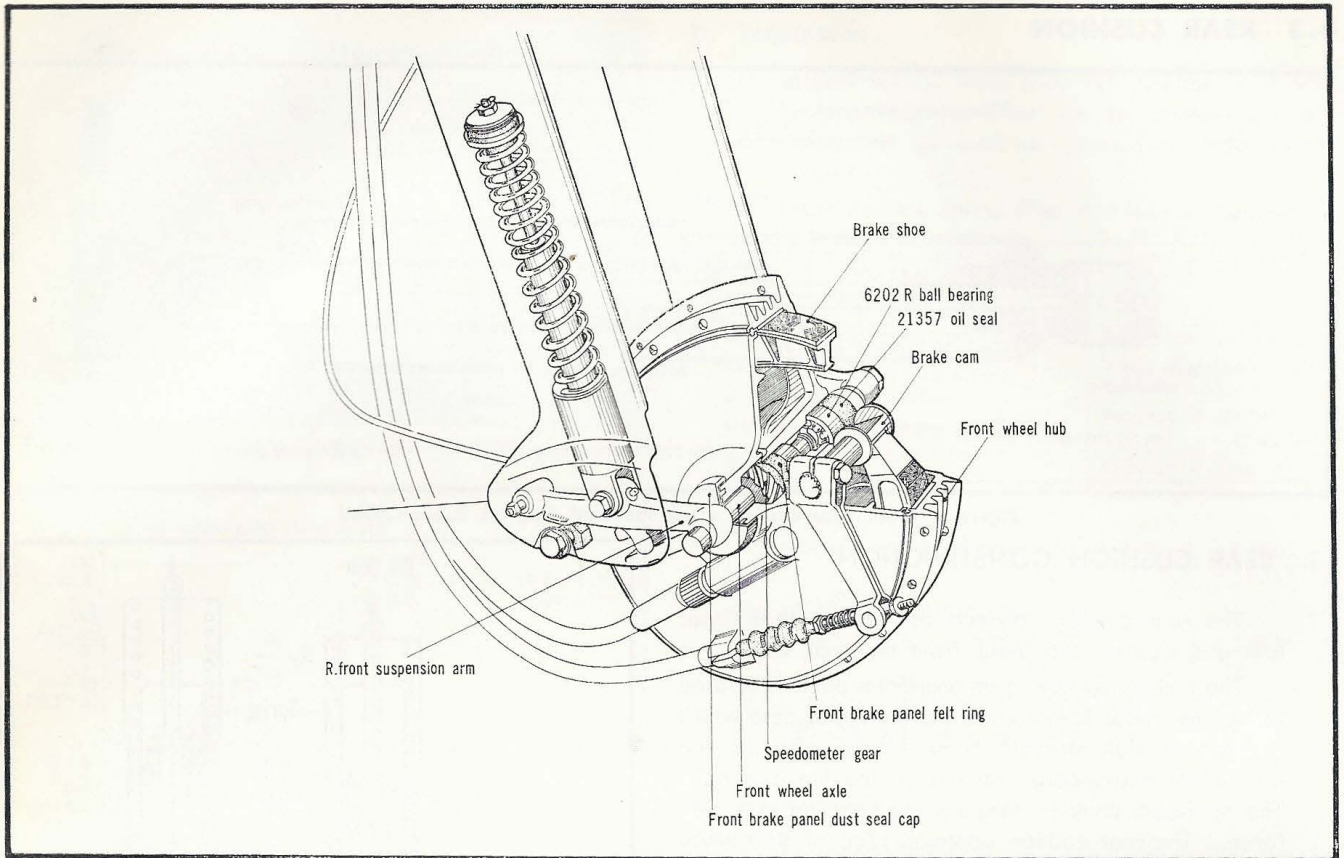

Figure 4-17. Front wheel cross section diagram

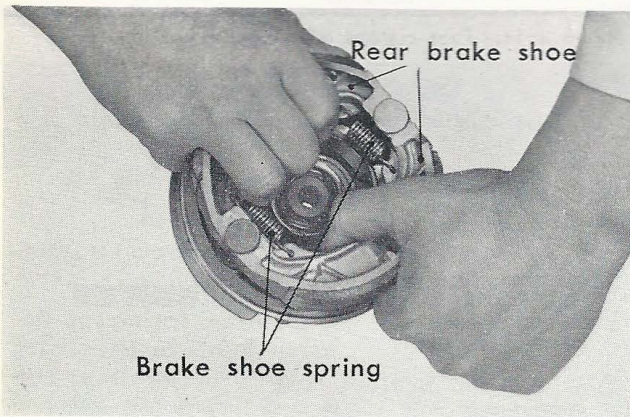

Figure 4-18. Removing front brake shoe

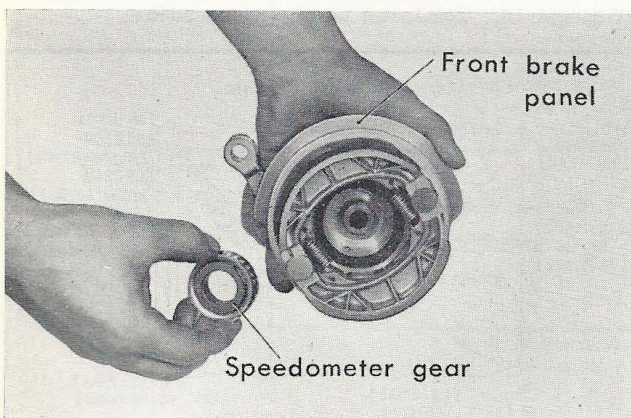

Figure 4-19. Removing speedometer gear

4.4 FRONT WHEEL

The front wheel axle and the axle nut assemble the cast aluminum alloy hub with the cast brake drum and two 6302R ball bearing with the front brake panel consisting of brake shoes and a speedometer gear.

When the brake is applied, the reaction is transmitted to the front fork by the brake panel stopper. A labyrinth is incorporated in the brake panel and the wheel hub to prevent the entry of water and dust into the hub interior. Tire size 2.25-17-4PR is used.

a. Disassembly

- (1) Place an adequate stand under the engine to raise the front wheel.
- (2) Remove the front brake cable and the speedometer cable.
- (3) Remove the axle nut and pull out the front wheel axle, then the front wheel and the front brake panel can be removed as a unit.
- (4) The brake shoe is fixed in place with the brake shoe spring; therefore spread the brake shoes apart and remove from the panel. (Fig. 4-18)

- (5) Remove the front brake cam and the speedometer gear from the front brake panel. (Fig. 4-19)
- (6) Remove the tire and tube from the rim using a tire lever and pull out the tube from the tire.

b. Inspection

- (1) Inspect the rim for runout and eccentricity. (Fig. 4-20)

	Standard Value	Serviceable Limit
Face Runout	0.7 (0.028 in.)	Repair if beyond 1.0 (0.040 in.)
Eccentricity	0.5 (0.020 in.)	Repair if beyond 1.0 (0.040 in.)

- (2) Check front axle diameter and for bend

	Standard Value	Serviceable Limit
Diameter	10 mm (.400 in.) -0.005 (.0002 in.) -0.050 (.0020 in.)	
Bend	0.2 (0.008 in.)	Repair or replace if over 0.5 (0.020 in.)

- (3) Check brake drum inside diameter. (Fig. 4-21)
Standard value → 110mm ± 0.2 (4.33 ± 0.008 in)
Serviceable limit → Replace if over 110mm (4.33 in)
- (4) Check brake shoe. (Outside diameter)
Standard value → 109.5mm +0 (4.291 +0 in)
-0.3 (4.291 -0.118 in)
Repair limit → Replace if over 105.5mm (4.153 in)

c. Reassembly

- (1) Reinstall the tire flap so that it is positioned over the spoke nipples. (Fig. 4-22)

- (2) Reinstall the tire and tube.

(Note)

- a. After reassembly of the tire, fill the tire with air to about $\frac{1}{3}$ of the specified pressure and tap the tire all around with a soft faced hammer to eliminate any tube twist or pinching. (Fig. 4-23)

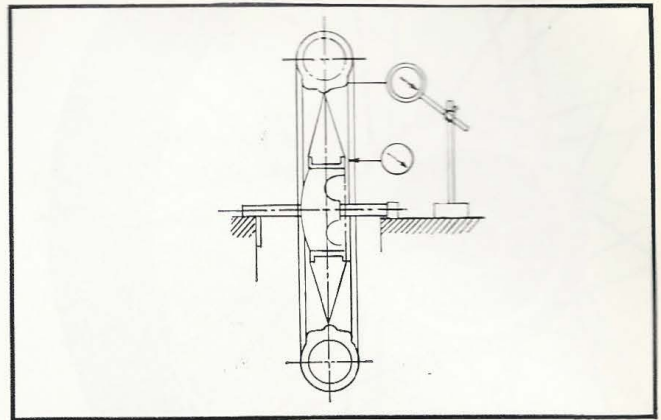

Figure 4-20. Measuring wheel runout

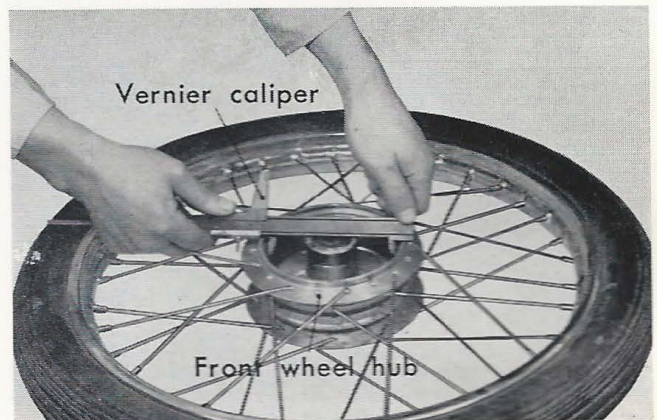

Figure 4-21. Measuring brake drum diameter



Figure 4-22. Installing tire flap



Figure 4-23. Tap the tire all around with a hammer

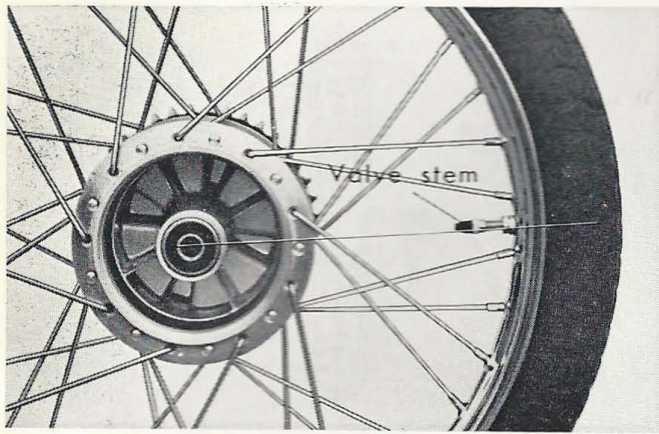

Figure 4-24. Installed angle of valve stem

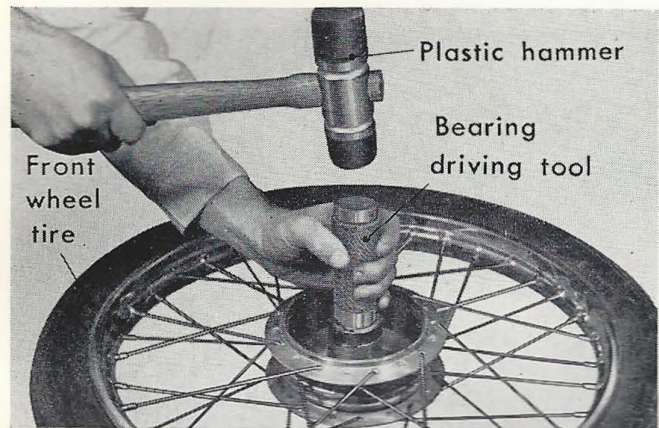

Figure 4-25. Installing 6202 R ball bearing by driving

- b. The valve stem must be pointed toward the axle, improperly seated valve stem may cause air leak. (Fig. 4.24)

- (3) Wash the old grease from the wheel hub and the bearing, and pack with new grease. Also fill the hub with grease and install the distance collar, followed by installation of the 6202R ball bearings. (Fig. 4-25)
- (4) After installing the bearings, reassemble the front wheel and the brake shoe in the reverse order of disassembly.
- (5) Install the brake cable and adjust the brake lever play.
(Refer to the Periodic Inspection and the section on adjustment)

Tire Air Pressure

Normal condition

- Front 1.6~1.8 kg/cm² (22.8~25.6 lb/in²)
Rear 2.0~2.2kg/cm² (28.4~31.2 lb/in²)

4.5 REAR WHEEL

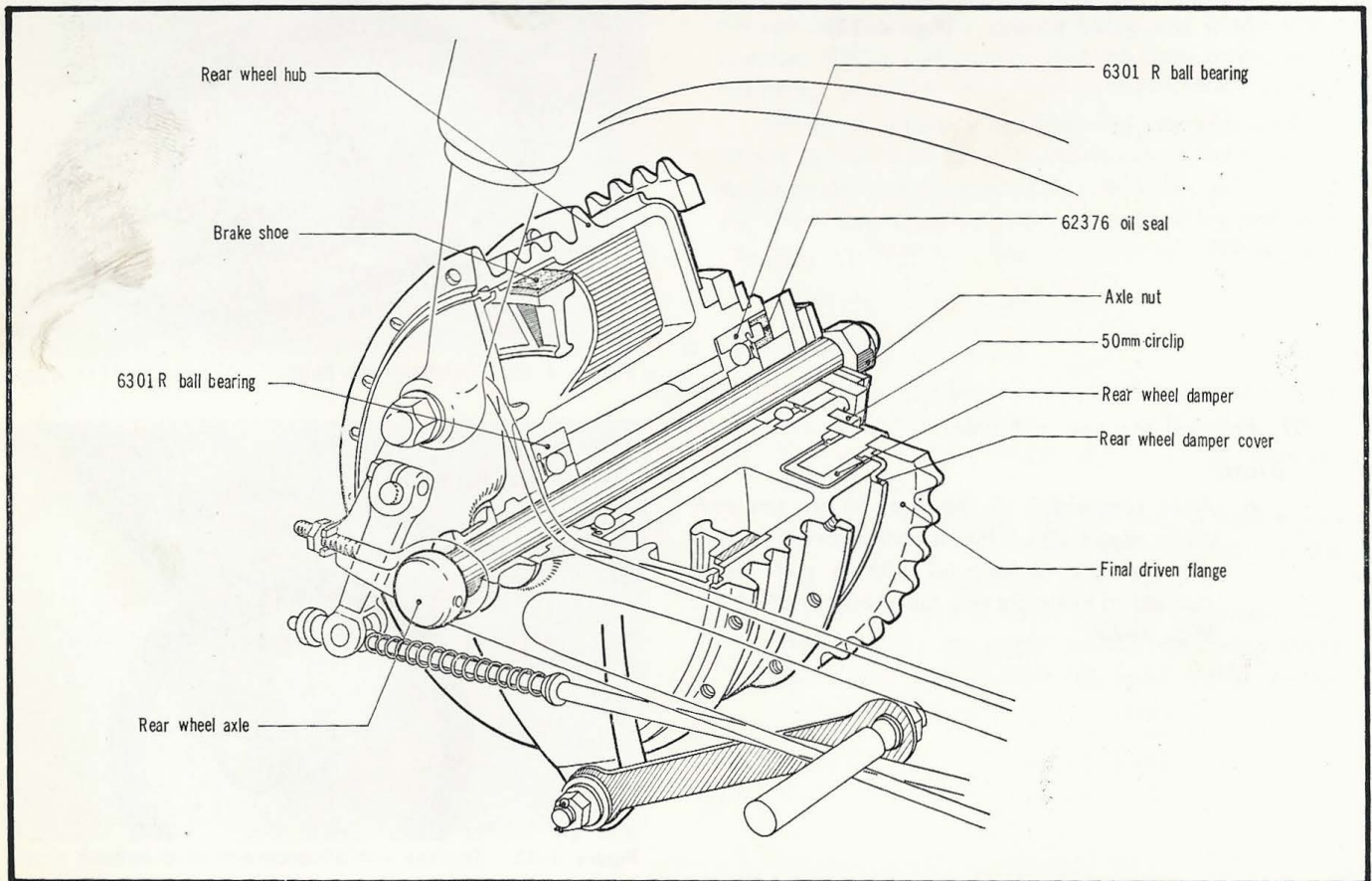

Figure 4-26. Rear wheel cross section diagram

4.5 REAR WHEEL

1. REAR WHEEL CONSTRUCTION

Similar to the front wheel, the rear wheel consist of a cast aluminum alloy rear wheel hub incorporating ball bearings, and a brake panel. A tire size 2.25-17-4PR is used with the rim made of rolled steel sheet. A specially designed tread pattern is used on the rear tire for better traction and to prevent side-slipping.

In addition, the rear wheel hub and the final driven flange have been made into an integral component for lightness.

a. Disassembly

- (1) Remove the muffler.
The muffler need not be removed for S50 and S65.
- (2) Remove the drive chain case lower half and disconnect the chain.
- (3) Remove the brake adjusting nut and separate the brake rod from the rear brake arm.
- (4) Separate the rear brake torque link from the brake panel.
- (5) Remove the rear wheel axle by removing the axle nut and then the rear wheel may be removed. (Fig. 4-27)
- (6) The brake shoe and the rear wheel is disassembled in the same manner as the front wheel.

b. Inspection

- (1) The rim runout and eccentricity is checked in the same manner as the front wheel and to the same standard.
- (2) Check the rear axle diameter for wear and bend. (Fig. 4-28)

	Standard Value	Repair Limit
Axle Diameter	11.957-11.984 (.4707 ~ .4720 in.)	
Bend	0.2 (.008 in.)	Repair or replace if over 0.5 (0.020 in.)

- (3) The brake drum ID and the brake shoe OD is checked in the same manner as the front wheel and to the same standard.
- (4) Check the brake lining for wear. (Fig. 4-29)
Standard value→3.5 (0.1378 in)
Serviceable limit—Replace if under 1.5 (0.0590)
- (5) Check spokes for looseness, retighten if necessary.

(Note)

The spoke should be retightened to the same tension as the other spokes.

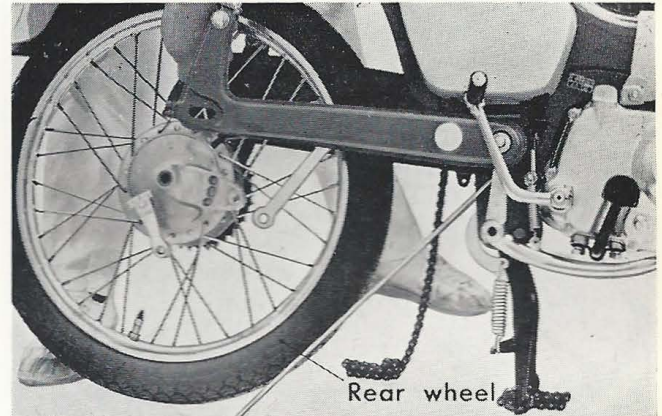

Figure 4-27. Removing rear wheel

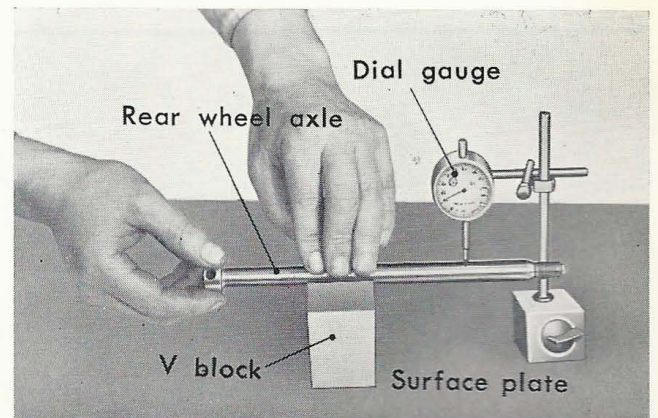

Figure 4-28. Measuring bend in rear axle

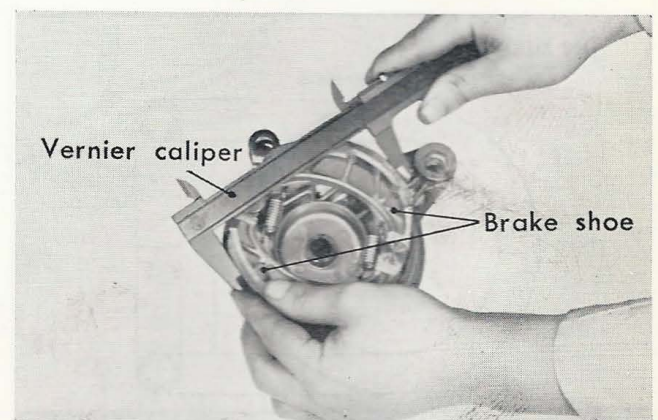

Figure 4-29. Measuring brake lining

a. Disassembly

- (1) Remove the exhaust pipe and the muffler.
- (2) Remove the brake rod from the brake arm by loosening the brake adjusting nut, then remove the brake pedal spring and the main stand spring.
- (3) Place a suitable stand under the engine and remove the rear brake pivot pipe by removing the 8 mm hex. nut fixing the rear brake pivot pipe, and the 3mm cotter pin; and by pulling out the rear brake pivot pipe, the stand and brake pedal can be removed from the frame as a unit. (Fig. 4-35)
- (4) Remove the step bar from the crankcase by removing the 8 mm hex. bolts.

b. Inspection

- (1) Inspect the brake pedal spring, main stand spring and the rear brake rod spring for loss of tension and corrosion. If loss of tension or corrosion is excessive, the spring should be replaced.
- (2) Inspect the brake pivot pipe and brake pedal for looseness. If excessively loose, the part should be adjusted to conform with the standard or replaced. (Fig. 4-36)
- (3) Check the rear brake pivot pipe outside diameter.
 $16.8 \text{ mm } -0.02 \text{ } \left(\begin{array}{l} 0.662 +0.0008 \text{ in} \\ -0.0040 \end{array} \right)$
- (4) Check the brake pedal pivot inside diameter.
 $16.8 \text{ mm } +0.027 \text{ } \left(\begin{array}{l} 0.662 +0.00106 \text{ in} \\ -0 \end{array} \right)$
- (5) Check the stand pivot hole inside diameter.
 $16.9 \text{ mm } +0.2 \text{ } \left(\begin{array}{l} 0.665 +0.008 \text{ in} \\ -0 \end{array} \right)$
- (6) Check the main stand spring free length.
 Standard value \rightarrow 80 mm (3.150 in)
 Serviceable limit \rightarrow Replace if over 88 mm (3.465 in)
- (7) Check the cotter pin for damage.
- (8) Check the brake shoes for damages.
- (9) Adjust the brake pedal play to 2~3 cm (0.787~1.181 in)
- (10) Check the main stand, brake pedal and step bar for deformities and repair as necessary or replace with new parts.

c. Reassembly

- (1) Clean the parts and lubricate the shafts with grease before reassembly.
 Reinstall the rear brake pivot pipe into the brake pedal and reinstall the stand on the frame and fix the stand in place with the rear brake pivot pipe.

(Note)

- Lock the rear brake pivot pipe in place with 8 mm hex. nut and install a cotter pin at the left-hand end.
- (2) Reinstall the step bar on the crankcase with four 8 mm hex. bolts. (Fig. 4-37)

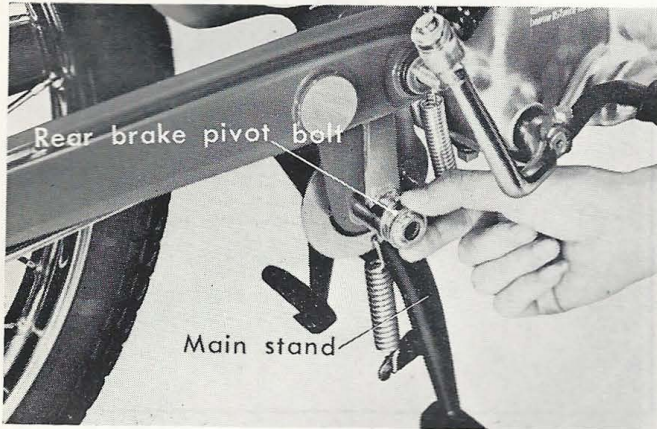

Figure 4-35. Removing brake pedal and stand

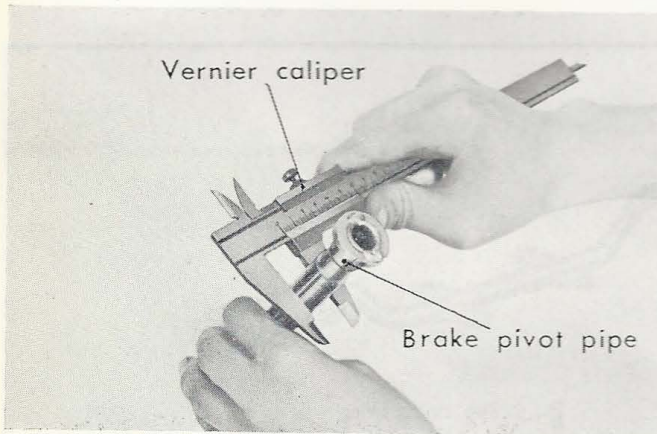

Figure 4-36. Measuring brake pivot pipe diameter



Figure 4-37. Installing step bar

- (3) Reinstall the brake pedal spring and main stand spring. (Fig. 4-38)
- (4) Reinstall the muffler.
- (5) Reinstall the brake rod on the rear brake arm.



Figure 4-38. Installing stand spring

(Note)

After connecting the rear brake, adjust the brake pedal play to 2~3cm (0.787~1.181 in). (Fig. 4-39)

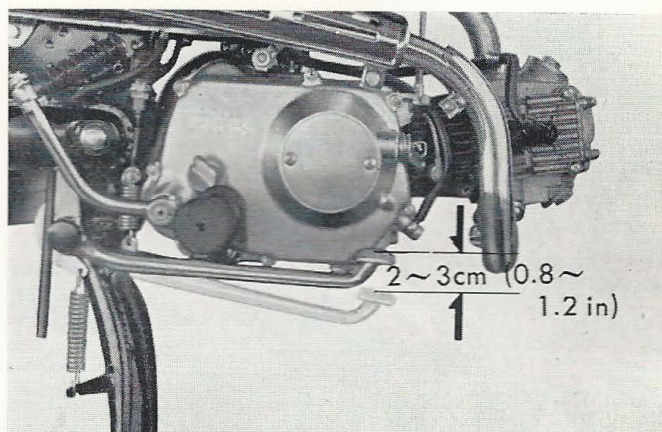

Figure 4-39. Play in the brake pedal

4.7 REAR FORK

The rear fork is of a swing arm type which pivots on the rear fork pivot bolt. The rear end of the fork is supported by the frame through the rear cushions.

a. Disassembly

- (1) Remove the rear wheel in accordance with section 4.51a.
- (2) Remove the drive chain upper half, lower half and final drive flange in accordance with section 4.8a.
- (3) Remove the 10mm nut fixing the rear cushion at the lower end.
- (4) Remove the rear fork pivot bolt by loosening the rear fork pivot nut, then the rear fork can be removed from the frame. (Fig. 4-40)

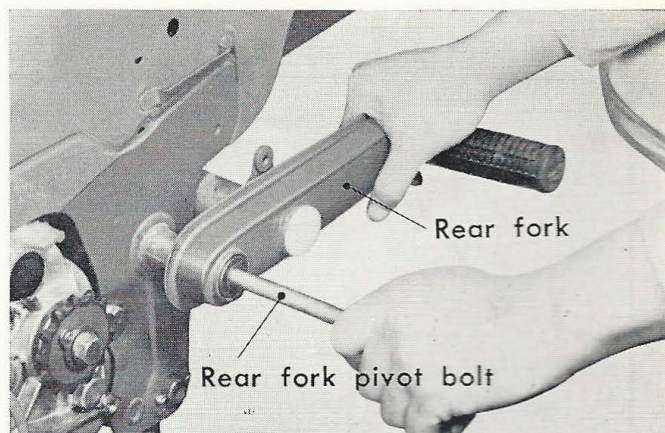

Figure 4-40. Removing rear fork

b. Inspection

- (1) Damaged or worn drive chain case gasket should be replaced.
- (2) Check the rear fork pivot rubber bushing. (Fig. 4-41)

Standard value→

C65, C65M	O.D 23 mm	+0.05	(0.0020 in)
C50, C50M		(0.9055)	+0.03 (0.0012 in)
S50	O.D 25 mm	+0.05	(0.0020 in)
		(0.9842)	+0.03 (0.0012 in)
S65	I.D 12.1mm	+0.2	(0.0079 in)
		(0.4764)	-0 (0 in)

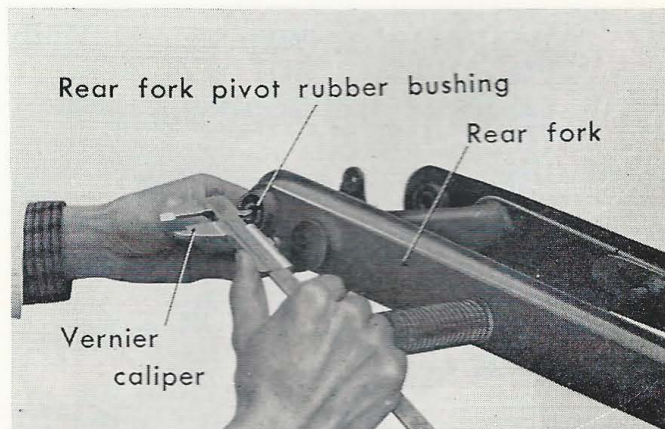

Figure 4-41. Measuring pivot rubber bushing

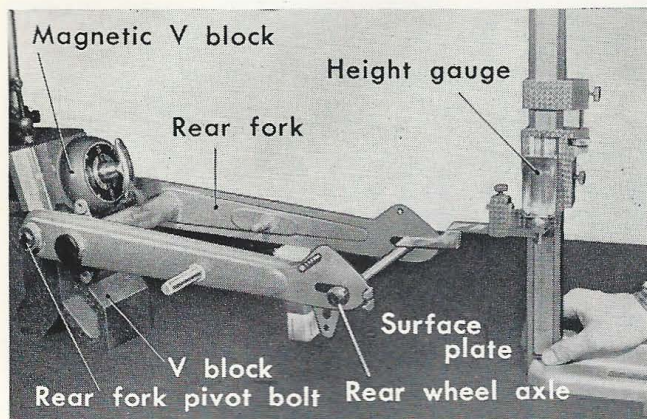

Figure 4-42. Measuring twist in rear fork



Figure 4-43. Installing chain case packing

Check the pivot rubber bushing for damage or aging and also for looseness in the fork. Replace defective bushings.

- (3) Check the rear fork for twist and deformation. If twist is over 1 mm (0.040 in) or the part is defective, replace with a new part. (Fig. 4-42)

c. Reassembly

- (1) Reassemble the rear fork in the reverse order of the disassembly.

(Note)

- a. Care should be taken when installing the chain case gasket. (Fig. 4-43)
- b. Check the pivot for looseness.
- c. Check the axle nut for tightness.
- d. Check L and R chain tension adjuster, they should both be set to the same alignment marks. Improper adjustment will affect the steerability.

4.8 DRIVE CHAIN

Engine output is transmitted from the engine through the clutch and the transmission where torque is converted to the chain drive. The chain used is a RK420-B type high strength chain to withstand high speed performance and high output. It is made endless by using only one joint clip and is housed within the chain cases to prevent dust from entering, preventing the rapid wear of the sprocket.

a. Disassembly

- (1) Remove the change pedal.
- (2) Remove the left crankcase cover.
- (3) Remove the chain case lower half.
- (4) Rotate the rear wheel so that the drive chain joint is positioned at the specified location shown in Fig. 4.44 and then disconnect the drive chain by removing the joint clip. (Fig. 4-44)

b. Inspection

- (1) Inspect the drive chain for wear and damages.

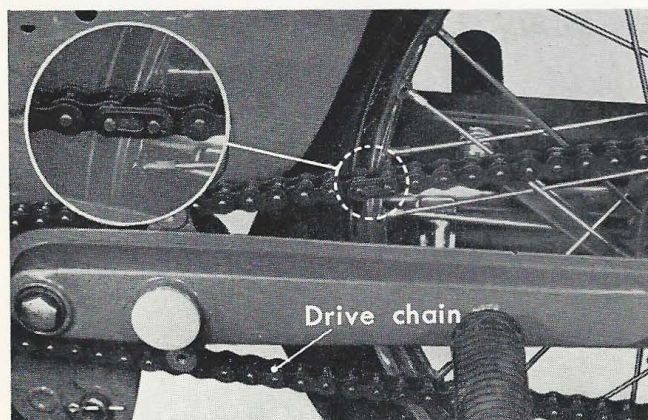

Figure 4-44. Disconnecting chain

c. Reassembly

(1) Reinstall and connect the drive chain.

(Note)

To facilitate the clip installation, perform the operation at the final driven sprocket.

- (2) Reinstall the lower chain case half.
- (3) Reinstall the left crankcase cover.
- (4) Reinstall the change pedal.

(Caution)

Whenever the drive chain has been removed or adjusted, the location of the alignment punch mark on the adjuster in respect to the marking on the rear fork must be the same on both sides. The chain slackness should be adjusted to 1~2 cm. (0.040~0.080 in). (Fig. 4-45)

Drive chain specification

- (1) Chain construction :
98 links, including the joint.
- (2) Breaking strength :
1,600 kg (3,520 lb) Min.
- (3) Tolerance on length :
97 links = $1231.9 + 0.25 \begin{matrix} 40.314 + 0.0098 \text{ in} \\ -0 \quad -0 \end{matrix}$
- (4) Sprocket C50, C50M : 39 teeth
C65, C65M : 41 teeth
S50 : 42 teeth
S65 : 43 teeth

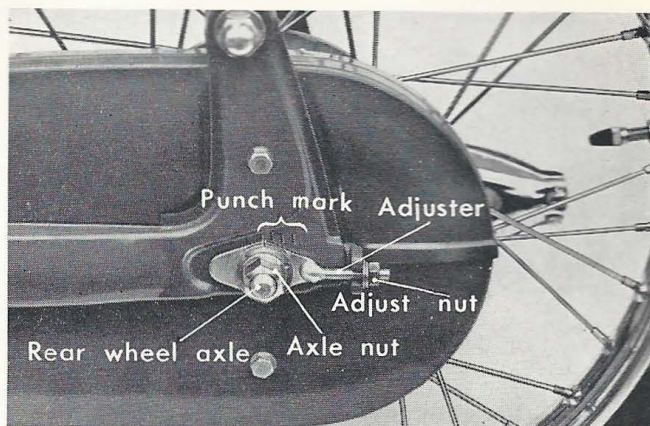

Figure 4-45. Chain adjuster mark

4.9 AIR CLEANER

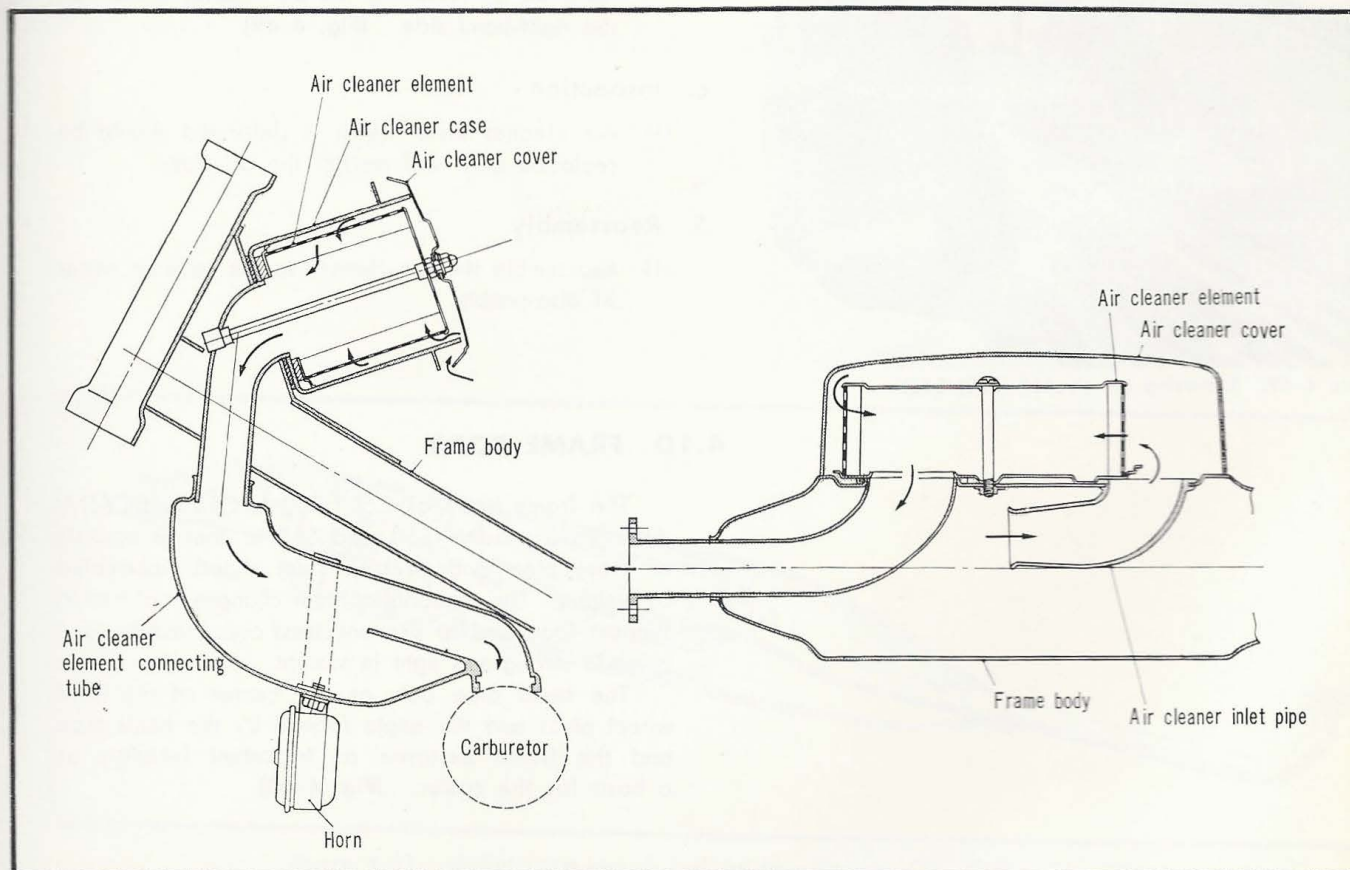

Figure 4-46. Air flow through air cleaner



Figure 4-47. Air cleaner connecting tube (C50, C50M, C65, C65M)



Figure 4-48. Removing air cleaner (C50, C50M, C65, C65M)

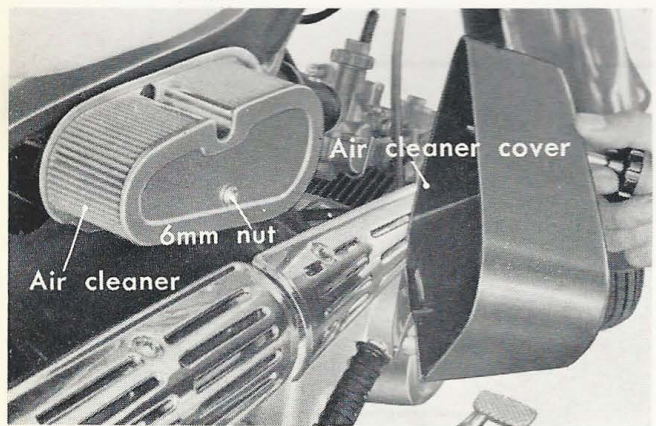

Figure 4-49. Removing air cleaner (S50, S65)

a. Air cleaner Construction

The function of the air cleaner is to clean by filtering, all air entering the engine through the carburetor and prevent the piston and cylinder from wear caused by dust and grit. Acetate fiber filter is used for filter element and the surface area made large as possible to provide an efficient air intake.

The air cleaner is mounted at the center of the front cover for models C50, C50M, C65 and C65M and at the center of the frame on the right hand side for models S50 and S65. All air entering the air cleaner is filtered, passes through the welded air cleaner pipe within the frame and after passing through the air cleaner rubber connecting tube, enters the carburetor.

The large size tube used in the C50, C50M, C65, C65M, is to provide good air flow and to heat the air as well as to minimize noise produced by air flow. (Fig. 4-47)

b. Disassembly

(1) The air cleaner of models C50, C50M, C65 and C65M can be removed by loosening the cap nut at the top of the air cleaner cover. (Fig. 4-48)

(2) The air cleaner on models S50 and S65 can be removed by removing the air cleaner cover on the right-hand side. (Fig. 4-49)

c. Inspection

(1) Air cleaner case which is deformed should be replaced as it will restrict the air flow.

5. Reassembly

(1) Reassemble the air cleaner in the reverse order of disassembly.

4.10 FRAME BODY

The frame body of C50, C50M, C65 and C65M, differ from models S50 and S65 in that it consists of steel pipe and pressed steel sheets, assembled by welding. The sectional contour changes in places to support load and to prevent stress concentration, and is made strong and light in weight.

The head pipe acts as the center of the front wheel pivot and the angle formed by the head pipe and the frame performs an important function as a basis for the caster. (Fig. 4-50)

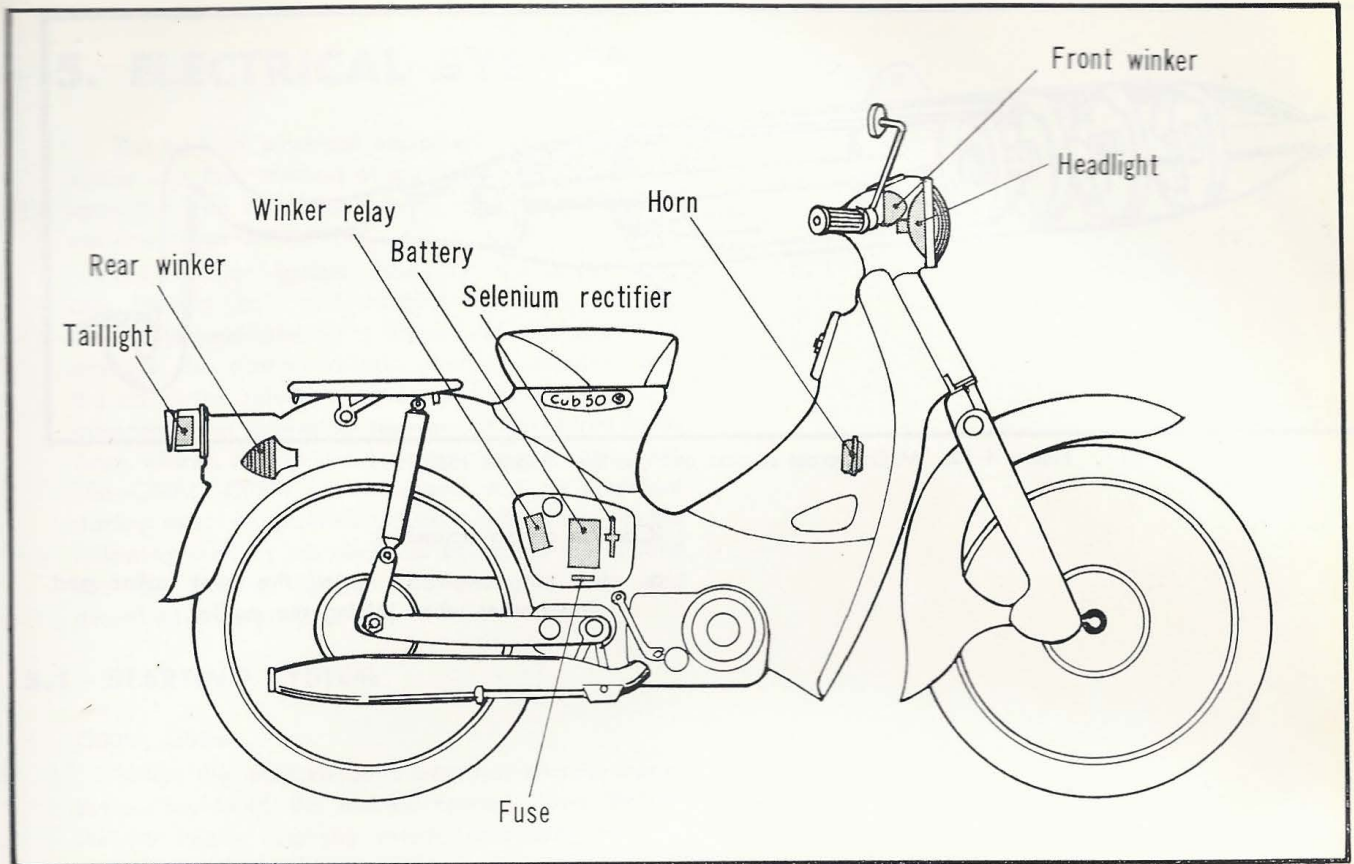

Figure 4-50. Frame body and electrical equipment installation diagram

4.11 MUFFLER AND EXHAUST PIPE

The muffler and the exhaust pipe have been made into an integral unit by welding to greatly improve the silencing effect of the muffler, in addition, it also serves to prevent the replacement of the muffler by a different type which may result in lowering the performance of the engine.

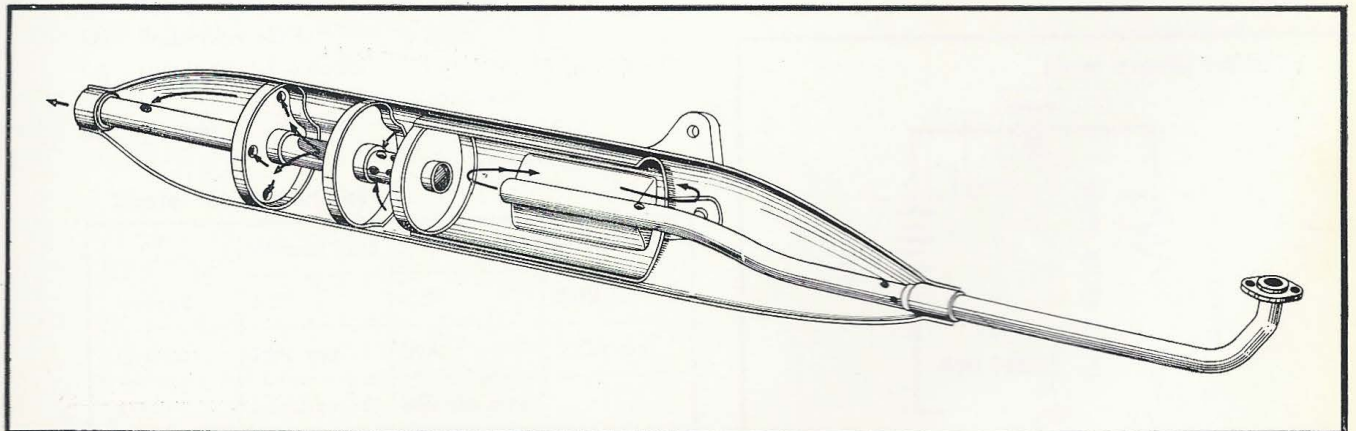

Figure 4-51. Muffler cross section and gas flow diagram (C50, C50M, C65, C65M)

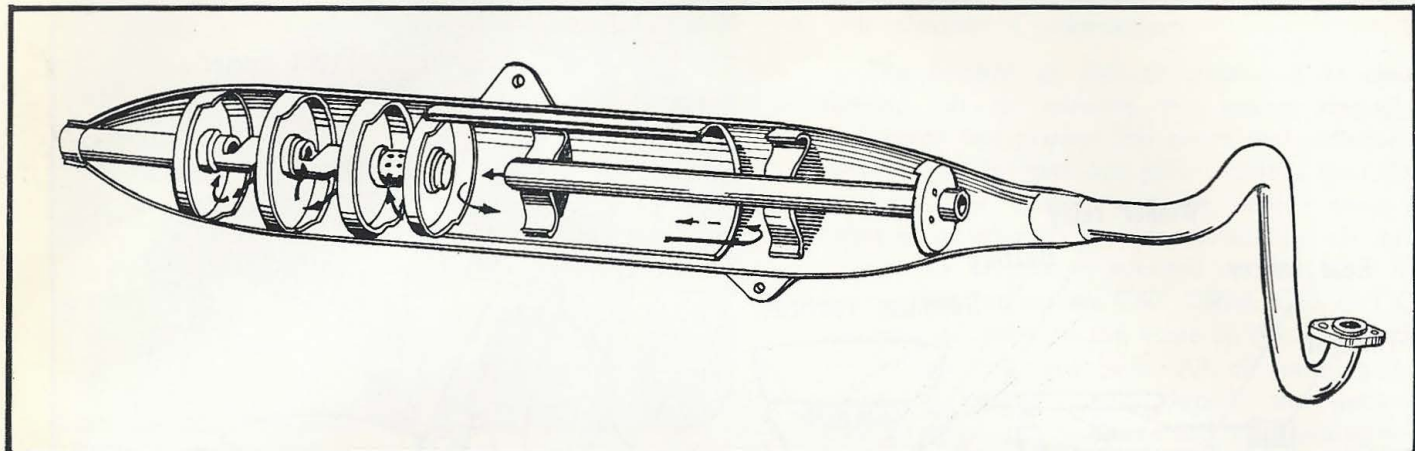

Figure 4-52. Muffler cross section and gas flow diagram (S50, S65)

(Caution during assembly)

- a. Do not forget to install the joint collar and pipe gasket when joining the muffler.

5. ELECTRICAL SYSTEM

The type of electrical equipment used on motor-cycles and their method of installation will, depending upon the type of wiring system, vary with the electrical requirements.

The ignition system used on the C50, C65 are ignition coil and contact breaker with the electricity generated by a special A.C. generator to produce the starting ignition. Further, together with the use of the selenium rectifier and battery, charging, transmission of power to the various connected loads (horn, winker, neutral lamp), discharging are performed. The C50M, C65M are equipped with an electrical starting motor to facilitate the starting function. In the following sections the electrical equipment are divided into the starting, ignition, generating systems and described separately.

5.1 STARTING SYSTEM

C50M, C65M

When the main switch is turned on and the starter button depressed, the electric current flows through the coil in the magnetic switch, energizing the coil and causing the plunger core to be drawn in to close the main contact.

This permits over 100A of current to flow from the battery direct to the starter to produce the necessary torque to turn over the engine for starting.

The starter armature speed is reduced by the planetary gear enclosed within the starter. The chain further reduces the speed and transmits the power to drive the crankshaft. In this way, the starter torque is made to rotate the crankshaft. To prevent the starter from being motorized after the engine starts, an overrunning clutch is incorporated into the A.C. generator rotor.

Starter Specifications

- | | |
|---------------------------|-------------------------------------|
| (1) Operating voltage | 6 V |
| (2) Rated output | 1.5 Kw |
| (3) Reduction ratio | 5.45 |
| (4) Direction of rotation | L.H rotation (viewing the sprocket) |
| (5) Weight | 1.7 kg (3.74 lb) |

Starter Characteristics

At the sprocket shaft	Without load	With load	Stalling
Voltage	5.5V	4.5V	3.3V
Current	28A max.	80A	220A max.
RPM	2,000rpm min.	450 rpm max.	
Torque		0.13kg-m min.	0.6 kg-m min.

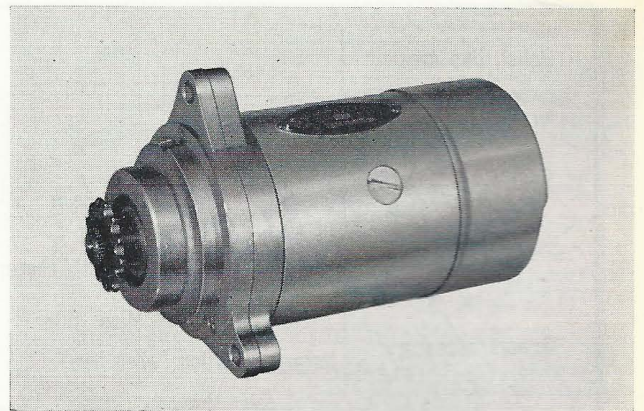

Figure 5-1. Starting motor

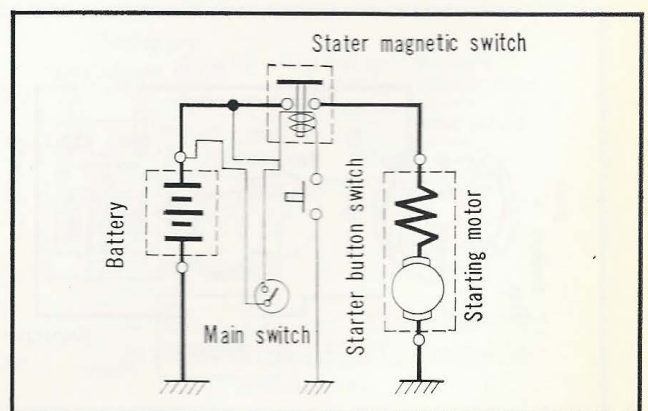

Figure 5-2. Starting circuit diagram

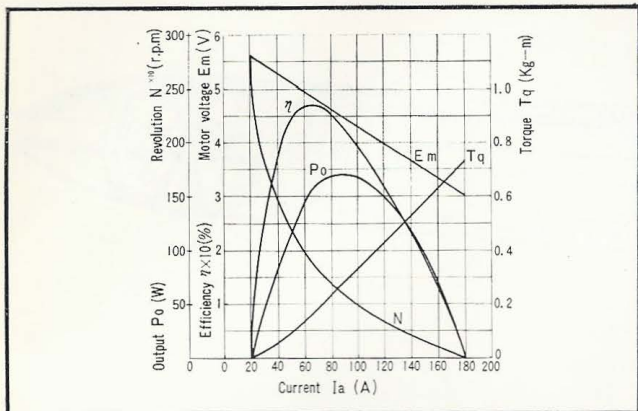

Figure 5-3. Performance chart

Use of the starter

- (1) If the engine does not start, do not operate the starter for longer than 10 seconds at each attempt, and allow the starter to rest for the same length of time before making another attempt.
- (2) Do not use the starter with the headlamp turned on.
- (3) If the overrunning clutch is defective and the starter is motorized after the engine starts, repair it immediately to prevent starter damage.

1. TROUBLE SHOOTING AND REPAIR

- Engine does not turn over when the starter switch button is depressed.
 1. The click of the starter relay is not heard when the starter switch button is depressed.
 - (1) Probable cause: Poor contact at the battery terminal due to looseness or corrosion. Corrective action: Inspect the terminal and if loose, tighten and apply a coat of grease; if corroded, remove the battery, pour hot water on the terminal to disconnect and then clean before reconnecting the lead wire, and then apply a coat of grease to prevent corrosion. Check the \oplus terminal particularly.
 - (2) Probable cause: Battery electrolyte level low. Check the electrolyte level and if below the lower level mark, add distilled water to the upper level.
 - (3) Check the electrolyte for proper specific gravity.
 - (4) When the starter switch button is making poor contact, disassemble the switch and clean.

If the trouble is not due to the causes above, take it to a specialist. In most cases, the cause is due to worn brushes or dirty commutator. A brush worn to less than 1/3 should be replaced with a genuine part. When dirty commutator is the cause, polish with a fine sandpaper and clean the carbon from the mica insulator as shown in Fig. 5.4 (Fig. 5-4)

- Starter magnetic switch fails to operate.

1. First, check to assure that the switch is on and then perform the inspection by the following procedure.
 - (a) Connect one lead of the starter magnetic switch to the \oplus terminal of the battery and the other lead to the ground and if an energizing click sound is not heard:
 - (1) The plunger coil is defective due to a broken wire, therefore, replace the coil. However, if an energizing click is heard in the starter relay, the defect is a poor contact in the starter switch button or the contact plate within the magnetic switch, therefore, disassemble the part and clean the contact areas. (Fig. 5-5)

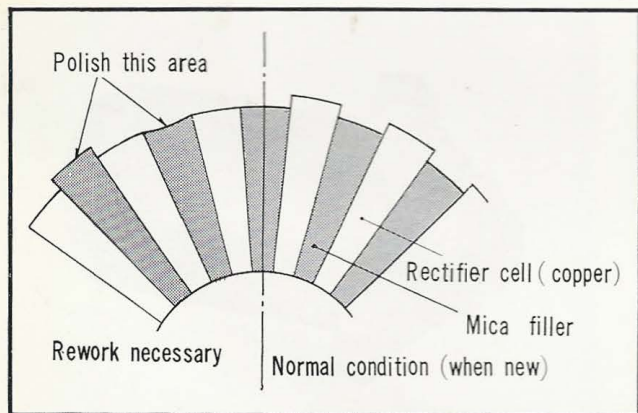

Figure 5-4. Dressing the commutator

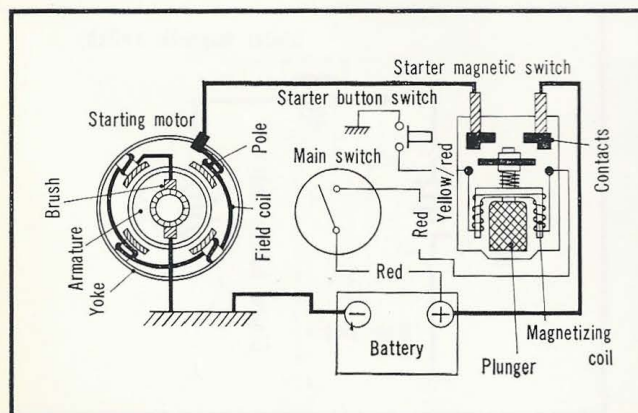

Figure 5-5. Starter wiring

5.2 CHARGING SYSTEM

A.C. Generator

The charging characteristics of the A.C. generator used in the C50, C65, S50 and S65 when under a specified load are shown in the diagrams at the right. However, when additional loads are connected to the system such as, fog lamps, and other accessories, there will be an increase in current draw by that amount and therefore, the charge cut-in speed of the generator will be at a higher speed and the charging amperage will be lower. (Fig. 5-6)

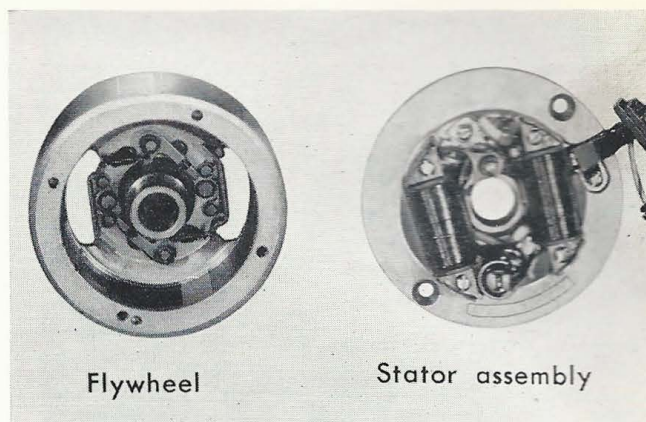

Figure 5-6. A.C. generator

The charging performance for the A.C. generator on the C50M, C65M models under normal load is shown in the chart at the right. (Fig. 5-7, 5-9)

Specification

- (1) Direction of rotation LH 300~11,000 rpm
- (2) Charge cut-in speed day 1,500 rpm max.
night 2,000 rpm
- (3) Charging amperage day/night
4,000 rpm 2AH $\begin{matrix} +1.5 \\ -0.5 \end{matrix}$
- (4) Load night headlight 25×2+
1.5+ignition coil
- (5) Wire color code Common lead : Brown
day-night system : Yellow
night system : White
neutral : Lt green/red
point : Blue

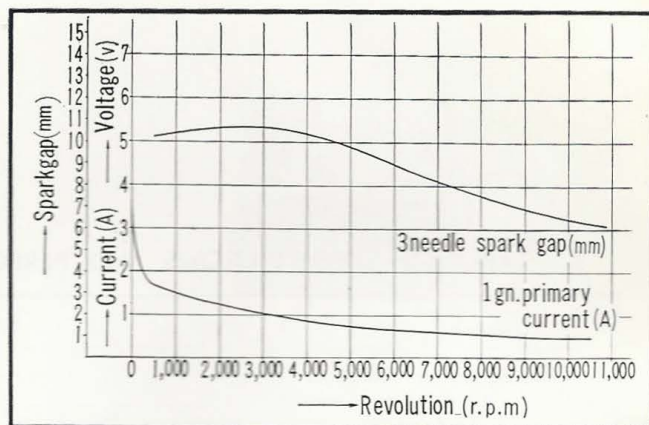

Figure 5-7. Ignition coil spark characteristic C50M, C65M

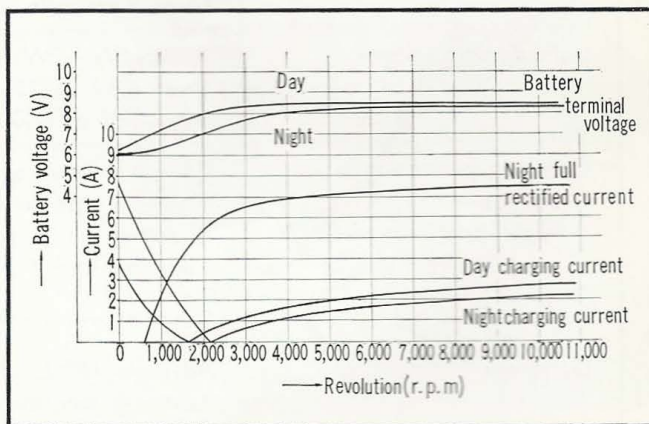

Figure 5-8. A.C. generator performance (C50M, C65M)

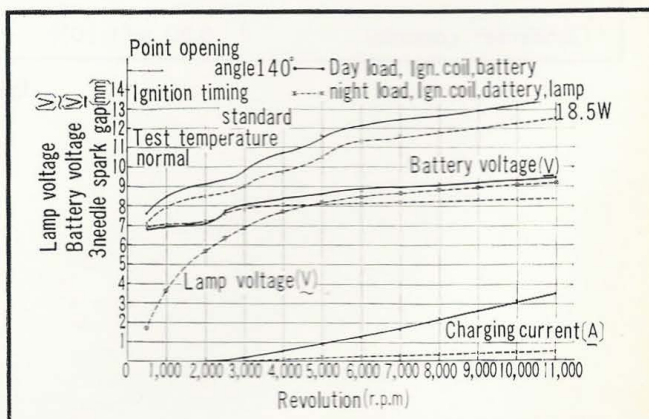

Figure 5-9. A.C. generator ignition coil performance

5.4 FLYWHEEL A.C. GENERATOR AND IGNITION COIL

1. A.C. GENERATOR (for C50M, C65M)

- (1) Direction of rotation
Right hand rotation when viewed from the installing position
- (2) Charging performance
Selenium rectifier (half-wave rectification), 6V, 11AH battery used.
- (3) Night operating load
Ignition coil + 15W + 2W + 1.5W
Charging speed, above 2400 rpm
Charging rate at 4000 rpm, $2 \begin{matrix} +1 \\ -0.5 \end{matrix} A$
- (4) Day operating load
Ignition coil
Charging speed, above 1500 rpm
Charging rate at 4000 rpm, $2 \begin{matrix} +1 \\ -0.5 \end{matrix} A$

2. TABLE OF SPECIFICATIONS AND PERFORMANCE

	S 65	C 65
Direction of rotation	Left hand rotation viewed from rotor end	
Sparking performances (assembled coil)	29700-111-1 Over 6 mm with 3 needle spark gap at 500 rpm Over 8 mm with 3 needle spark gap at 3000 rpm	29700-112-1
Lighting performance	With 15W + 2W + 1.5W load connected Over 5.8V at 2500 rpm Below 9V at 8000 rpm	
Charging performance Day operation Night operation	Charging cut-in speed under 2000 rpm (battery voltage 6.5-7V) Charging rate at 8,000 rpm, $2.2 \pm 0.5A$ (battery voltage 8V min) Charging cut-in speed under 2000 rpm (battery voltage 6.5-7V) Charging rate 8,000 rpm, $0.4 \pm 0.2A$ (battery voltage 7V min)	
Breaker	Contact pressure $750 \pm 100g$, point gap 0.35 ± 0.05 mm (0.020 ± 0.0020 in.)	
Governor	Advance $15^\circ \pm 1.5^\circ$ Advancer operating speed 2500 ± 150 rpm Advancer terminating speed $4000 \begin{matrix} +200 \\ -0 \end{matrix}$ rpm	
Condenser capacity	0.30 mf $\pm 10\%$	

Ignition coil point cut-off current 3.5A max at 8000 rpm

3. INSPECTING SPARKING PERFORMANCE

On the C50, C65, S50, S65 the flywheel A.C generator and an externally mounted ignition coil is used. An A.C ignition system is employed and, therefore, when performing the ignition coil test, the specified flywheel A.C generator must be used. However, a simple method of determining the serviceability is made by the following three methods.

- (1) The most simple method is to remove the spark plug and perform the starting procedure with the spark plug grounded to the engine. When a strong spark of bluish white color is produced, it is an indication of satisfactory ignition coil and flywheel A.C generator. (Fig. 5-10)

If no spark is produced, it is an indication of defective primary coil of either the ignition coil or flywheel A.C generator.

- (2) Another method is to measure the resistance of the ignition coil and the flywheel A.C generator primary coil. (Fig. 5-11)

Ignition coil resistance (26700-111-29700-113-2)

1. Primary coil: Resistance between primary black leads and case should be approximately 4.5Ω
2. Secondary coil: Resistance between high tension lead and ground should be approximately 9.5Ω .

When the resistance measurement across the flywheel A.C generator primary coil is approximately 1.3Ω lower than the above value, the cause may be a short or grounding; an infinite resistance would indicate an open circuit.

(Caution)

Resistant measurement of the primary coil must be made with the breaker points opened and the condenser lead wire disconnected as a leaky condenser will give an improper indication.



Figure 5-10. Testing spark plug firing



Figure 5-11. Testing ignition coil

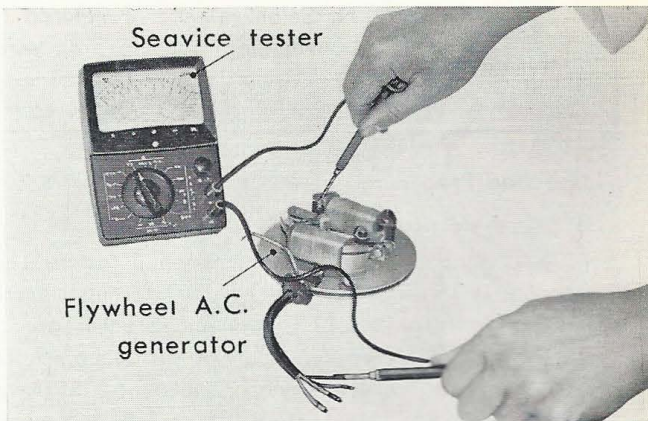

Figure 5-12. Measuring resistance

4. TROUBLE DIAGNOSING THE FLYWHEEL GENERATOR

Sympton	Location	Probable cause	Corrective action
Hard Starting	A. Spark plug	Dirty or fouled plug Too wide a gap	Clean or replace Adjust or replace
	B. Breaker	Dirty or burnt points Punctured condenser	Repair or replace Replace
	C. Timing	Too far advanced	Adjust
	D. Coil	Primary winding opened Secondary winding opened, shorted between layers, defective insulation Pin-hole in high tension cord	Replace Replace Replace
Low intensity of lamps	E. Rotor	Loss of magnetism	Replace
	F. Lamp	Too large a rating Poor contact	Replace Repair
	G. Wiring	Poor connection Poor contact in lighting switch	Repair Replace
	H. Lamp coil	Shorted across the layers	Replace
	I. Rotor	Loss of magnetism	Replace
	J. Battery	Discharged Poor terminal contact	Recharge or replace Repair
Lamp not lit	K. Lamp	Burnt filament	Replace
	L. Wiring	Broken wire Poor contact in lighting switch	Repair Replace
Battery discharges	M. Charging coil	Open coil winding	Replace
	N. Selenium rectifier	Punctured condenser Broken wire, poor connection	Replace Repair
	O. Wiring	Loss of magnetism	Replace
	P. Rotor	Open coil winding	Replace

Inspection Procedure

(1) Hard starting

First conduct the spark performance test in section 4 (1) and check to see that the condition of the spark plug is satisfactory; perform the starting operation and if a good spark is produced at the plug gap, it indicates that the ignition coil, magnet and breaker are all in satisfactory condition. The fault can be assumed to be in the timing. When no spark is produced, check the breaker, ignition coil and flywheel A.C. generator.

(2) Whenever there is any malfunction of the lamps or the battery system, first check for poor wiring connection or grounding. Next, start the engine and measure the voltage at the output terminals. If the output voltage are normal, check the battery and the lighting system for trouble.

5.4 SPARK ADVANCER

The C50M, C65M use the battery as a source of power and produces the high voltage spark across the plug gap with the ignition coil and contact breaker. However, a good strong spark is of little value unless the sparking is timed to the engine's requirement. For this purpose, a spark advancer is incorporated to automatically regulate the ignition timing. The spark advance characteristic is shown in Fig 5.14. (Fig. 5-13, 5-14)

Performance and Specification

Spark Advancer

- (1) Direction of rotation : Left hand
- (2) Mechanically allowable maximum RPM : 15,000 RPM

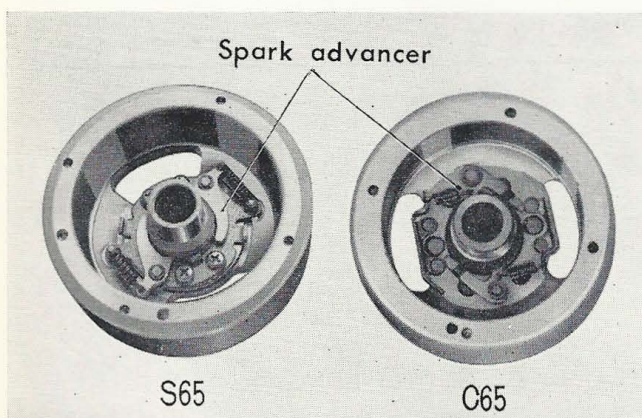

Figure 5-13. Spark advancer

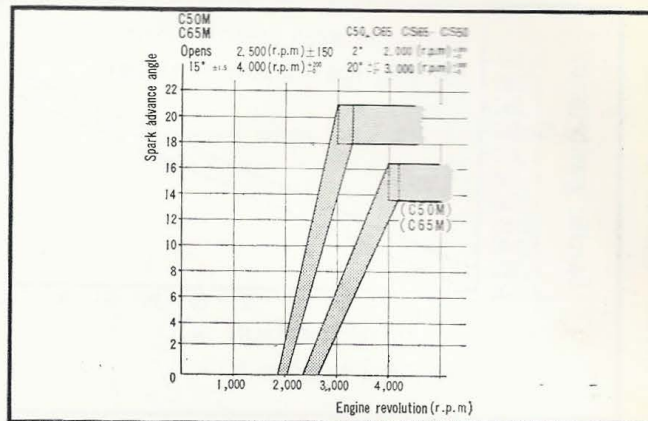

Figure 5-14. Spark advance performance chart

a. Inspecting the Spark Advancer

- (1) The check of the spark advancer operation may be performed on the engine with a timing light. When checking a removed unit, spread the counterweights apart with the fingers and if the weights return to the normal position smoothly when released, the advancer is operating satisfactorily. (Fig. 5-15)
- (2) Check for broken spring.

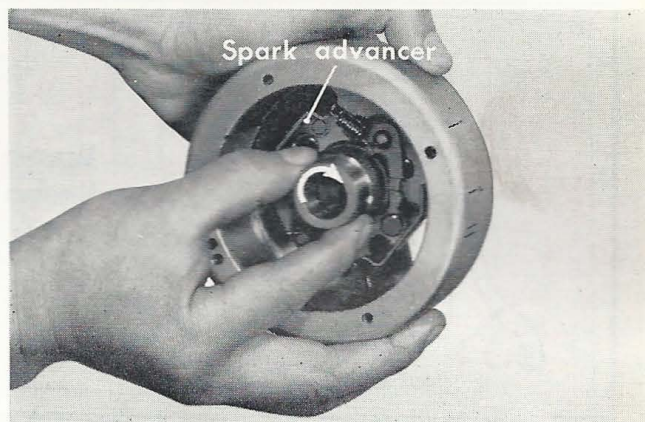

Figure 5-15. Inspecting spark advancer

5.5 BATTERY

1. CONSTRUCTION

The battery stores the electricity produced by the generator for use as a source of power for the safety items such as the turn signal lamps. At present, all battery used for small type vehicles are of a lead storage type inclosed in a plastic case. The construction and the name of the component parts are shown in Fig 5.17 (Fig. 5-16, 5-17)

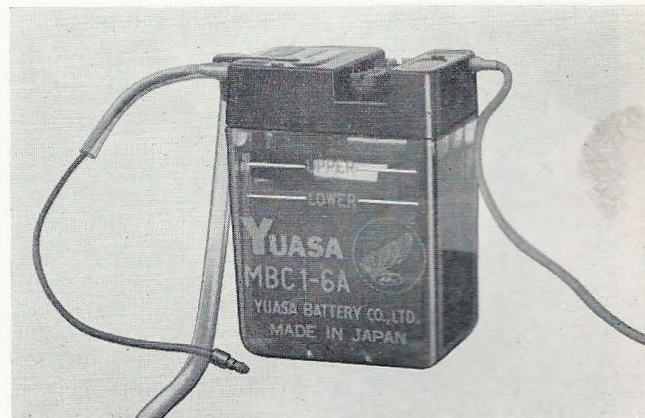

Figure 5-16. Battery

2. RATING

Type	MBC 1-6
Voltage	6V
Capacity	2AH (10 hour rate)
Normal charging rate	0.2A
Specific gravity of electrolyte (when fully charged)	1,260-1,280 at 20°C(68°F)

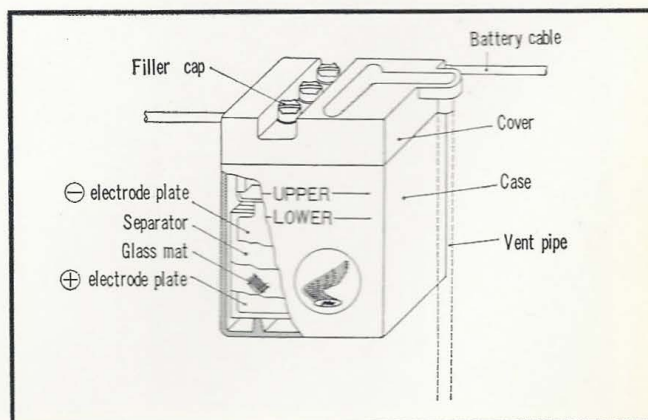

Figure 5-17. Construction of battery

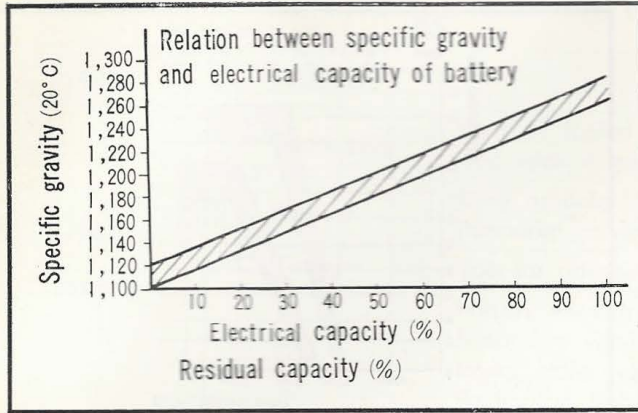

Figure 5-18. Specific gravity and residual capacity chart

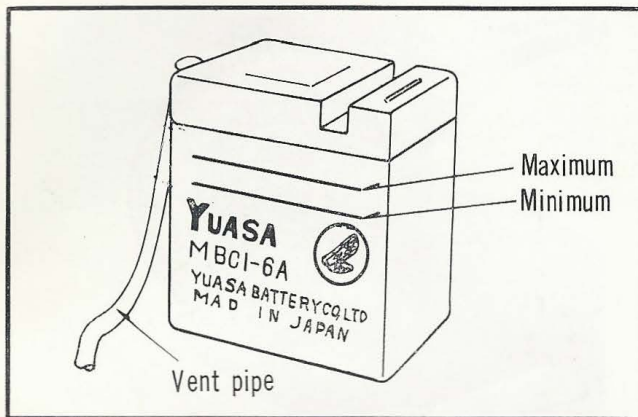
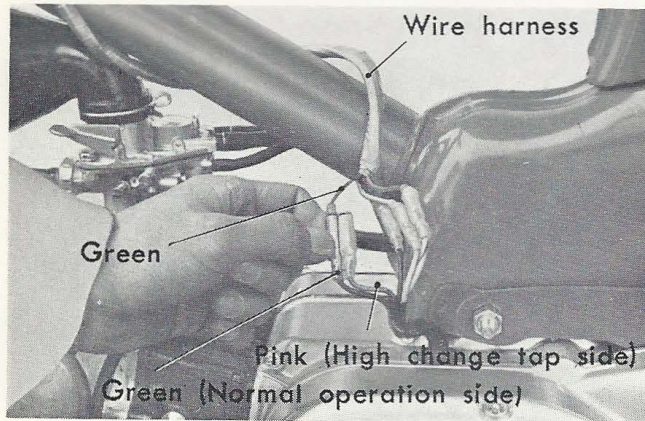

Figure 5-19. Electrolyte level indicator



3. INSTRUCTION ON USE AND SERVICING

(1) High Charging Rate Output Tap

The dynamo on this motorcycle is provided with a high charging rate output tap. Connectors are installed on the leads of both the normal and high charge rate taps to simplify making the change. When riding constantly at a speed of 20 to 25 km/h (12.5~15 m/h) use the high charge rate tap to maintain the battery in proper charge.

(2) Check specific gravity

Before using the battery, check the capacity and if the specific gravity of the electrolyte is below 1,220 at 20°C (68°F) (less than 75% capacity), the battery should be recharged.

(Caution)

The relation between the battery capacity and the specific gravity (residual capacity) is shown in Fig 5.18. When the specific gravity is 1.189 at 20°C (68°F) (less than 50% capacity) the residual capacity is small and if continued to be used in such a condition, it will eventually lead to trouble as well as shortening the battery life, therefore, the battery should be recharged as soon as possible (Fig. 5-18)

- (3) Inspecting the electrolyte level. As shown in Fig 5.19, if the electrolyte level falls below the **LOWER LEVEL**, remove the filler cap with a screw driver or an appropriate tool and fill the battery to the **UPPER LEVEL** with distilled water or filtered water. Do not fill beyond the **UPPER LEVEL**. (Fig. 5-19)

with frequent use of the turn signal lamps and stop light.

- (3) Making many short trips or when considerable amount of riding is done in relatively heavy traffic, requiring frequent stop and go.
- (4) When motorcycle is ridden only at frequently intervals.

(Note)

- (1) Battery electrolyte tends to evaporate readily when the motorcycle is ridden for an extended period at high speed such as during a tour, therefore, a more frequent check of the electrolyte should be made.
- (2) When constant replenishing of the battery electrolyte is required, it is an indication of over-charging, therefore, the battery charging lead should be reconnected to the lead for the normal charging rate.

Procedure for changing rates

Remove the front cover and locate the tandem outer cord connector located between the wire harness and the dynamo leads. The wires to the connectors are colored green and pink. For normal charging rate, the green cord of the wire harness is connected to the green lead from the dynamo. For high charging rate, the green cord is connected to the pink lead.

The connection should be made to the high charging rate terminal to extend the life of the battery, under the following conditions:

- (1) When considerable night riding is anticipated.
- (2) Riding at slow speed, 20 to 25 km/h (12.5~15 m/h)

4. SERVICING DURING USE

- (1) Refrain from using the turn signal lamps beyond necessity.
Continuous use of the turn signal lamps will discharge a fully charged battery within 40 minutes.
- (2) Vent pipe
Whenever the vent pipe is removed during recharging, it must be reconnected when the battery is installed.
Care should be excersized not to restrict the opening (Fig. 5.19).

5. BATTERY CHARGING PROCEDURE

The instructions for normal and rapid charging are of follows :

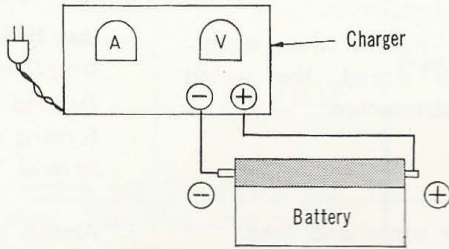
	Normal charge	Rapid charge
Connection	 <p>Connect the charger \oplus to the battery \oplus " " \ominus " \ominus When charging two or more batteries at a time, perform the charging in series.</p>	Same as left
Charging current rate	0.2A	0.6-1.0A
Checking for full charge	<ol style="list-style-type: none"> (1) Specific gravity: 1.260-1.280 (20°C: 68°F) maintained constant (2) Voltage: Battery attains and maintain a voltage over 7.5V when charged at 0.2A <p>The battery is fully charged when the above condition is obtained. During the final phase of charging, large volume of gas will be emitted.</p>	<ol style="list-style-type: none"> (1) Specific gravity: 1.260-1.280 maintained (20°C: 68°F) (2) Voltage: When large volume of gas is emitted from the battery (in about 2-3 hours for fully discharged battery), reduce charging rate to 0.2A. Battery is fully charged when a voltage of 7.5V is maintained
Charging duration	By this method, a fully discharged battery will be fully charged in approximately 12-13 hours.	By this method, a fully discharged battery will be fully charged in approximately 3-4 hours.
Remarks	<ol style="list-style-type: none"> (1) When the charging is urgent, quick charging method may be used, however, the recommended charging current rate should be under 2A. (2) If the charger is equipped with a timer, the specified method should be followed. (3) The rapid charge method above refers to battery charging with a standard charger. 	

6. TROUBLE SHOOTING AND PREVENTATIVE MAINTENANCE

The battery is being recharged all the while the engine is running. Further, while running, the load such as the use of the turn signal lamps horn are placed on the battery (discharged), as the result, the battery is being discharged at the same time it is being recharged. In the long run, the discharge and the recharge is in balance. The system has been designed in this manner. Under certain condition when the balance is upset, then trouble develops.

To obtain maximum life from the battery, it is necessary to locate this trouble and take the appropriate action early.

The trouble to the battery are mainly external such as cracked case, broken terminal, disconnected lead wire. The battery condition, trouble, corrective action are shown in the following table.



Figure 5-20. Sulfation

7. TROUBLE SHOOTING AND CORRECTIVE ACTION

Trouble	Probable cause	Correct action
<p>A. Sulfation The electrode plates are covered with white layer or in spots (Fig. 5-20).</p>	<ol style="list-style-type: none"> 1. Charging rate is too small or else excessively large. 2. The specific gravity or the mixture of the electrolyte is improper. 3. Battery left in a discharged condition for a long period. (left with the switch turned on) 4. Exposed to excessive vibration due to improper installation. 5. During cold season when motorcycle is left stored, the wiring should be disconnected. 	<ol style="list-style-type: none"> 1. When stored in a discharged condition, the battery should be recharged once a month even when the motorcycle is not-used. 2. Check the electrolyte periodically and always maintain the proper level, 10-13 mm (0.400-0.518 in.) above the plates. 3. In a lightly discharged condition, the battery may be restored by overcharging at 20H. Depending upon the condition, performing recharging and discharging several times may be sufficient.
<p>B. Self discharge Battery discharges in addition to that caused by the connected load.</p>	<ol style="list-style-type: none"> 1. Dirty contact areas and case. 2. Contaminated electrolyte or electrolyte excessively concentrated. 	<ol style="list-style-type: none"> 1. Always maintain the exterior clean. 2. Handle the replenishing fluid with care.
<p>C. Discharge rate large Specific gravity, gradually lowers and around 1.1, the turn signal lamp and horn no longer function.</p>	<ol style="list-style-type: none"> 1. The fuse and the wiring is satisfactory; the loads such as turn signal lamp and horn does not function. In this condition the motorcycle will operate but with prolong use, both the \oplus and \ominus plates will react with the sulfuric acid and form lead sulfide deposits, (sulfation) making it impossible to recharge. 	<ol style="list-style-type: none"> 1. When the specific gravity falls below 1,200 (20°C : 68°F), the battery should be recharged immediately. 2. When the battery frequently becomes discharged while operating at normal speed, check the generator for proper output. 3. If the battery discharges under normal charge output, it is an indication of overloading, remove some of the excess load.
<p>D. High charging rate The electrolyte level drops rapidly but the charge is always maintained at 100% and the condition appears satisfactory. A condition which is overlooked. (specific gravity over 1.260)</p>	<ol style="list-style-type: none"> 1. The deposit will heavily accumulate at the bottom and will cause internal shorting, causing damage to the battery. 	<ol style="list-style-type: none"> 1. Check to assure proper charging rate. 2. When overcharge condition exist with the proper charging rate, place an appropriate resistor in the charging circuit.
<p>E. Specific gravity drops Electrolyte evaporates</p>	<ol style="list-style-type: none"> 1. Shorted 2. Insufficient charging 3. Distilled water over-filled 4. Contaminated electrolyte 	<ol style="list-style-type: none"> 1. Perform specific gravity measurement. 2. If the addition of distilled water causes a drop in specific gravity, add sulfuric acid and adjust to proper specific gravity.

5.6 SPARK PLUG

Spark plug performs one of the most important functions in the engine ignition system. The high voltage produced by the magneto or the ignition coil is received by the spark plug and causes the high tension spark to jump across from the center electrode of the spark plug to the side electrode within the engine combustion chamber. The spark ignites the compressed fuel mixture in the combustion chamber and produces an explosion which operates the engine. Even under various adverse conditions, durability and reliability is required. (Fig. 5-21)

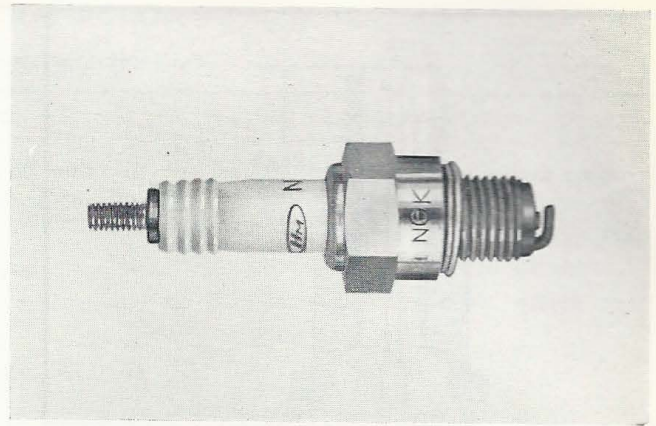

Figure 5-21. Spark plug

1. SPARK PLUG

The operation of the engine can be determined by the condition of the plug. The firing area of the insulator colored white, gray or light gray indicates good condition and is performing satisfactorily.

2. HEAT RANGE OF THE SPARK PLUG

The firing area of the spark plug insulator is exposed to carbon and oil while the engine is operating, and to prevent its build-up, plugs are designed to burn off any deposits by the heat of combustion.

Spark plugs which are too cold will not burn off the carbon and oil deposits and will cause shorting of the high tension voltage resulting in the engine to mis-fire. In the opposite case, the power output will be drastically reduced.

In order to prevent the above troubles, the surface of the insulator firing area must be maintained at approximately 500-870°C (932-1600°F) range. This temperature is referred to as the self-cleaning temperature.

The temperature of the spark plug will vary to a considerable degree with the type engine and design, riding condition, and fuel.

In order for the plugs to function properly under the different conditions, it is necessary for the plugs to properly dissipate temperature of the plug caused by the heat of combustion.

The rate of heat dissipation of the spark plug is the heat range of the spark plug. A spark plug which readily dissipates the heat and which is difficult to overheat is referred to as a "Cold Type". A spark plug which retains the heat and which will burn readily is referred to as a "Hot Type". On engine operating at high temperature, a spark plug which is difficult to overheat, in other words, the cold type spark plug is used and for engine operating at low temperature a hot type spark plug is used. (Fig. 5-22, 5-23)

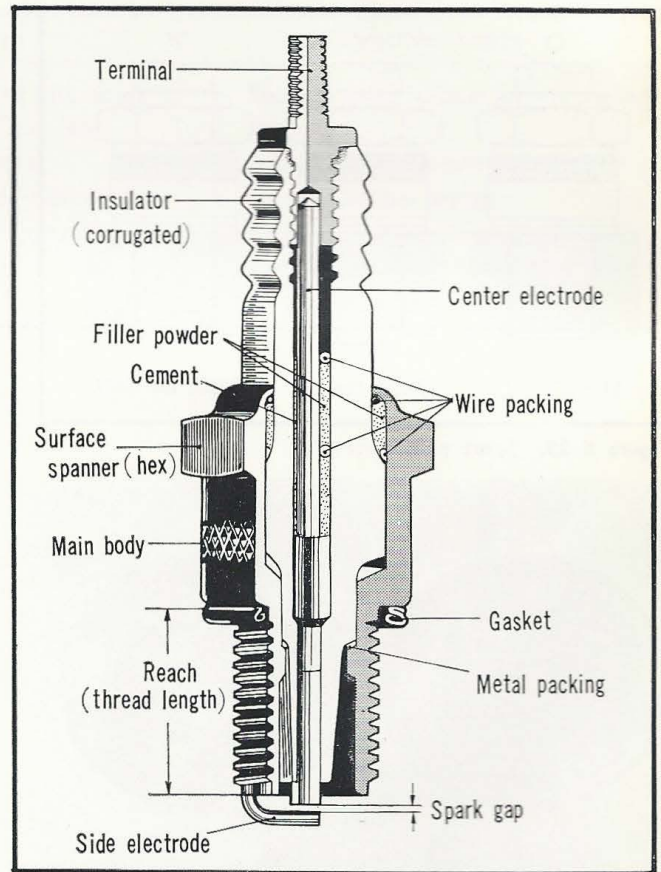

Figure 5-22. Construction of spark plug

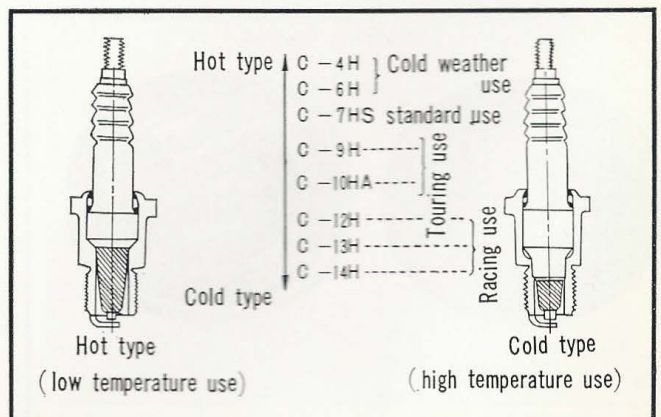

Figure 5-23. Heat range of spark plug

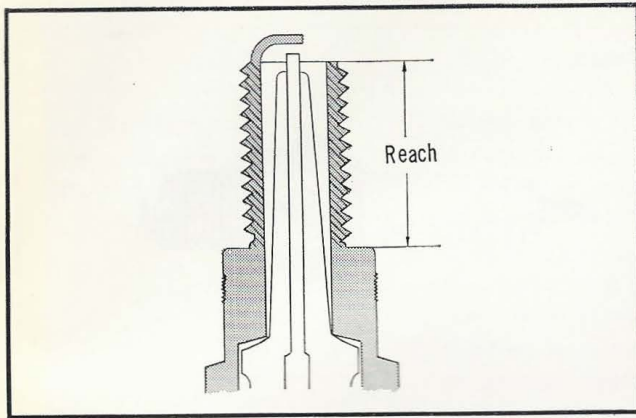

Figure 5-24. Spark plug reach

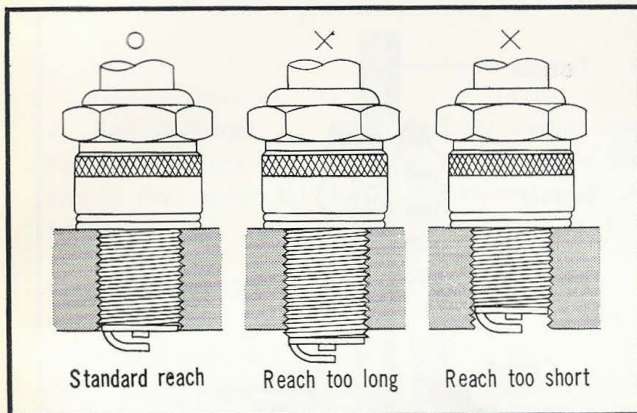

Figure 5-25. Spark plug electrode

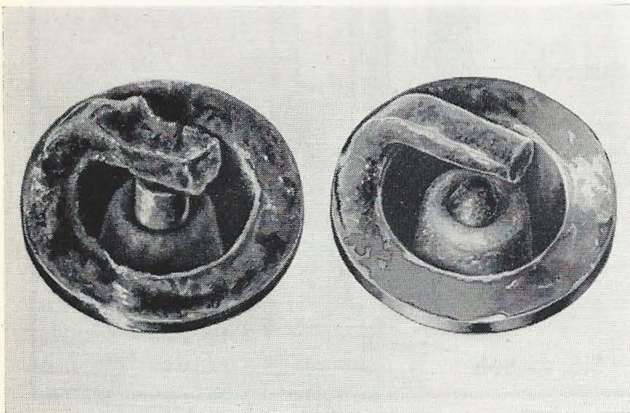

Figure 5-26. Sooty plug

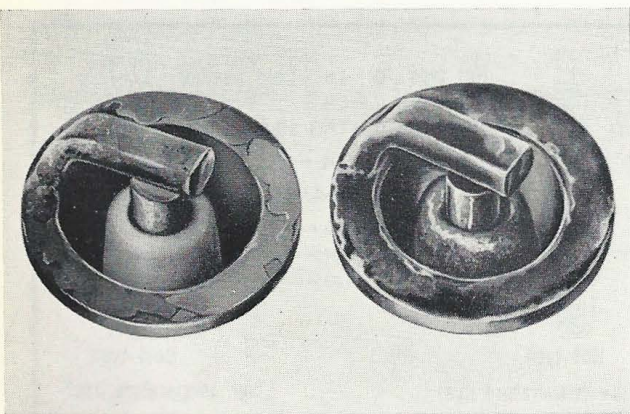

Figure 5-27. Overheated plug

The correct spark plugs for the different models are shown in Fig. 5-23.

3. SPARK PLUG REACH

The reach of the spark plug refers to length of the threaded section. Different model motorcycles have cylinder head designed with different depth of spark plug hole, therefore, the spark plug with the proper reach should be used. (Fig. 5-24, 5-25)

The following unsatisfactory conditions will occur if plugs of improper reach are used.

- ① Reach too long
 - a. Carbon will be deposited on the exposed thread and cause damages to the threads in the spark plug hole during plug removal
 - b. The plug tip will become overheated, causing pre-ignition.
- ② Reach too short
 - a. Carbon will be deposited on the threads at the bottom of the plug hole and when the spark plug of the proper reach is installed, the plug hole threads will be damaged.
 - b. Due to the cavity left by the short reach, exhaust gas will accumulate causing decrease in power output, overheating, engine malfunction.

4. SPARK PLUG REACH

The spark plug firing, regardless of whether the primary power supply is from an A.C. Generator or a D.C. source, is produced by the high voltage secondary coil. The voltage generated will vary with the engine speed, however, with the proper spark gap, there is sufficient voltage to produce a spark for the required explosion. If the spark gap is too wide, a very high voltage is necessary to produce a spark and, in which case, a misfire will result at low speed.

On the other hand, if the gap is too narrow, a spark will be produced at a very low voltage and since the spark will be of a low energy, an incomplete explosion will take place, resulting in engine malfunction.

5. MAIN SPARK PLUG TROUBLE AND CORRECTIVE ACTION

A. Poor starting, occasional misfire, knocks during acceleration.

Symptom	Probable Cause	Corrective Action
1. Dirty plug electrodes (sooty) 2. Plug wet with fuel 3. Flushed over	Misfire caused by the insulation of the electrodes due to carbon deposits or fouling with oil. 1. Too rich a fuel mixture. 2. Excessive intake of fuel during starting. 3. Dirty insulator and excessive spark gap.	1. Adjust the spark gap, adjust carburetor. 2. Dry the spark plugs, change the procedure on the use of choke. 3. Clean and properly adjust the gap.

B. Malfunctions when climbing, backfires, pre-ignition.

Symptom	Probable Cause	Corrective Action
1. Electrodes not noticeable dirty. 2. Electrodes excessively eroded. 3. Small deposits on the insulator. 4. Indication of burning.	1. Insufficient torquing of the spark plug causing exhaust gas leak. 2. Too lean a fuel mixture. 3. Ignition timing too far advanced. 4. Improper plug, heat range too low.	1. Replace plug gasket or retorquing the plug. 2. Adjust the carburetor. 3. Adjust ignition timing. 4. Replace with spark plug of higher heat range. (higher numbered plug)

(Fig. 5-26, 5-27)

5.7 TURN SIGNAL LAMP

The flasher system wiring is as shown in circuit diagram Fig. 5-29. A single relay which is used for both the right and left flashing operation is installed on the right side of the frame body.

There are several types of flasher relay for the different functioning principle. The solenoid thermo type is used on the Honda (Fig. 5-28, 5-29)



Figure 5-28. Flasher relay

1. INSTALLATION INSTRUCTION

- (1) Always use the specified turn signal lamp bulbs. Bulb of a different size will cause a change in the flashing rate.
- (2) Make sure that the connections are good and the grounding secure. A poor grounding will cause the lamps to fail in flashing.
- (3) When the turn signal lamp fail to flash, it is an indication of a burned out bulb.
- (4) The connectors are color coded to identify the wires. Insert the connectors completely to prevent loosening during riding and causing short circuit.

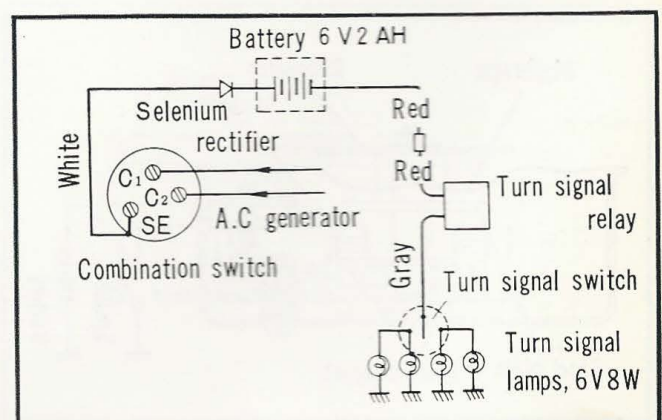

Figure 5-29. Flashing circuit diagram

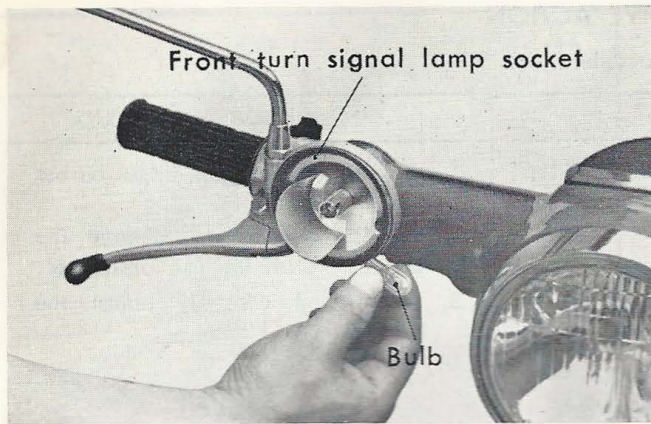

Figure 5-30. Turn signal lamp spring contact holder

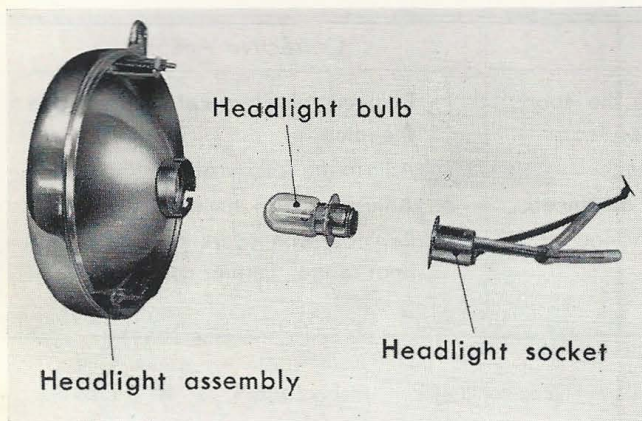

Figure 5-31. Construction of headlight

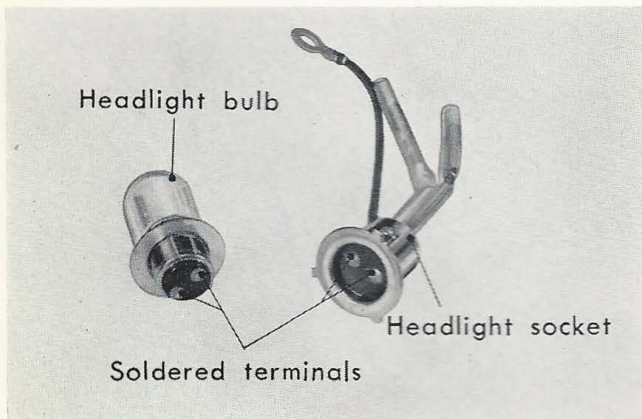

Figure 5-32. Soldered terminals

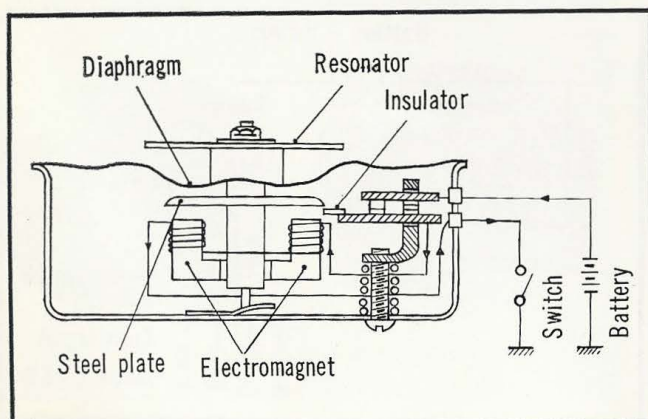

Figure 5-33. Horn

2. FLASHING TROUBLE AND CORRECTIVE ACTION

- 1) Burned out bulb
Cause: Similar to the headlight bulb; due to high voltage generated during riding.
Corrective action: Replace with new bulb.
- 2) Poor socket contact
Cause: Uneven height of the socket or bulb contacts.
Corrective action: File the higher contact to provide a uniform pressure at all the contacts.
(Fig. 5-30)
- 3) The above 1 and 2 will cause only the troubled light to be affected, however, when both the front and rear bulbs fail to light, it is an indication of a defective turn signal switch or a break in the flashing circuit. Locate the trouble and repair.

5.8 HEADLIGHT

The purpose of the headlight is to provide safe riding at night, therefore, make sure that the following conditions are adequate.

1. HEADLIGHT TROUBLE AND CORRECTIVE ACTION

- 1) Burned out
Cause: May be due to defective bulb, however, the main causes are due to high voltage generated during riding, excessive vibration when riding at high speed over bad roads. (Fig. 5-31)
Corrective action: Replace with new bulb
- 2) Poor socket contact
- 3) When poor contact is caused by corrosion, polish the contacts with a file or sand paper. (Fig. 5-32)
- 4) Broken wiring
Cause: Wire breaking loose at the soldered end due to vibration from riding over bad roads.
Corrective action: Resolder the wire to the proper contacts.

5.9 HORN

The horn is used to provide an audible warning. An electrical current is passed through the stationary

coil to create an electromagnet which causes a steel diaphragm to vibrate and produce sound. When the coil is energized, the steel core is drawn in, at the same time breaks the contact which opens the horn circuit and causes deenergizing of the coil.

The steel core is connected to the resonator plate and causes it to vibrate, producing the sound.

The trouble symptoms of the horn are, no sound produced, weak sound, poor quality of tone. Perform the inspection in the following manner.

- (1) If the horn does not produce any sound, first check to see if the fuse is blown. (Fig. 5-34)
- (2) When checking any defect condition, connect the horn directly to the battery with separate leads.
 - a. Proper sounding will indicate a defective horn switch.
 - b. When the sound is weak, adjust the screw at the back of the horn. (Fig. 5-35)
Turn the screw to the right to decrease the sound.
Turn the screw to the left to increase the sound.
- (3) Horn produces a sound of poor quality. Remove the horn and check for poor point contacts, remove the wires at the terminals and measure the resistance of the coil. The resistance should be approximately 1Ω .

Battery Installation

- (1) When installing a fully charged battery, clean the exterior thoroughly with water.
- (2) Apply a coating of grease or vaseline after connecting the leads to the battery terminals to prevent corrosion.
- (3) Make sure that the \oplus and \ominus connections are properly made.

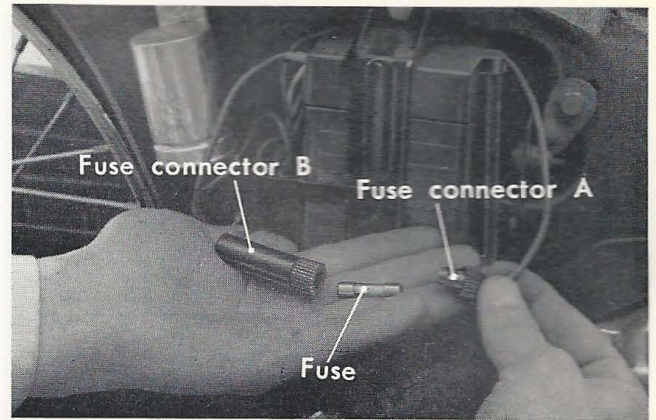

Figure 5-34. Fuse



Figure 5-35. Adjusting the horn

5.10 SELENIUM RECTIFIER

The function of the rectifier is to convert A.C. to D.C. and is used on all A.C. generator or A.C. generating coil.

It utilizes the phenomena of allowing the current to flow in one direction and permitting only a small amount of current to flow in the reverse direction. The construction of the rectifier is shown in Fig. 5.36 with a moisture-proof paint applied. (Fig. 5-36)

The electrode alloy side, compared to the opposite side having a steel plate, is raised approximately 1 mm (0.040 inch) making it easy to recognized even with the surface painted. The C50M, C65M are equipped with a full wave rectifier, whereas, the C50, C65, S50, S65 are equipped with half wave rectifiers.

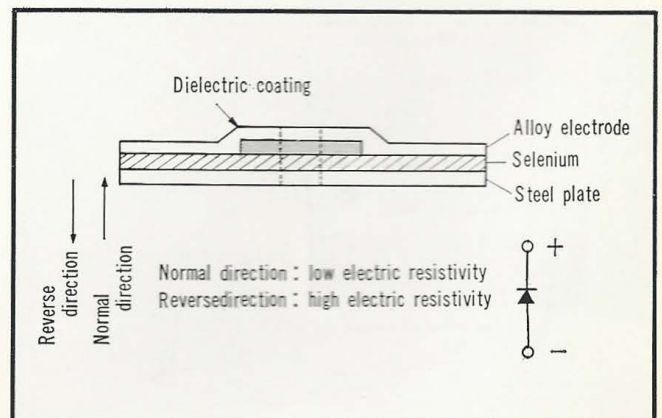

Figure 5-36. Selenium rectifier construction diagram

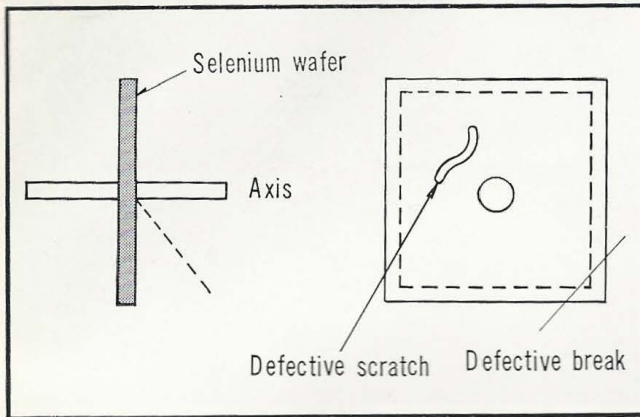

Figure 5-37. Damages to selenium wafer

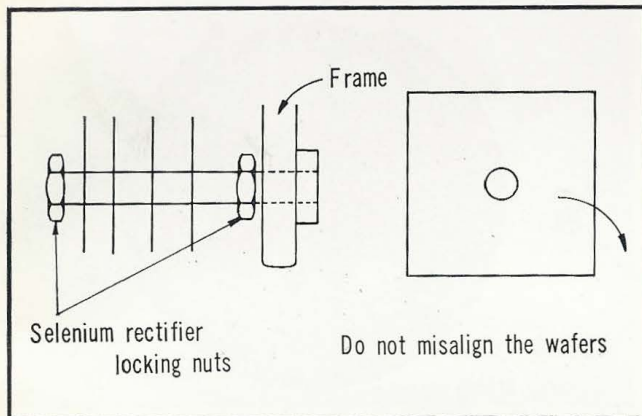

Figure 5-38. Selenium rectifier installation instruction

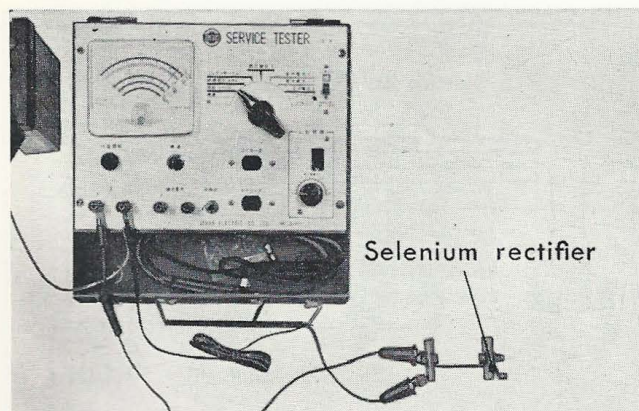

Figure 5-39. Connecting the test leads

Selenium Rectifier Installation and Handling.

- (1) Do not bend, cut or scratch the selenium wafers. (Fig. 5-37)
- (2) The rectifier locking nut (painted nut) should not be loosened or the wafers rotated. (Fig. 5.38) Any movement will cause the electrode alloy to peel, affecting the rectification function, further, it will destroy the moisture-proofing and thereby, shorten the life of the selenium rectifier.
- (3) Take adequate caution not to permit rain, salt water, water or battery electrolyte to get on the selenium rectifier, in which case it will cause the amount of current flowing in the reverse direction to increase. Further, if the selenium wafer is exposed to moisture for any length of time, oxide will be produced on the surface, resulting in a shorted condition and the following trouble will occur.
 - a. Battery will become discharged.
 - b. Malfunction of the charging system.
- (4) Do not start the engine in a condition where the battery or the load is not connected. (the circuit being electrically open)

Example :

- a. Loose or disconnected lead at the battery terminal.
- b. Loose or disconnected terminals on the lead between the battery and the \oplus side of the selenium rectifier.
- c. Running without a battery.
- d. Loose or disconnected terminals between the frame ground and the \ominus side of the selenium rectifier (C50, C65, S50, S65 does not use a frame ground, however, the C50M, C65M use a full wave rectifier and it is important that no looseness at the frame exist).

If the engine should be started under the above condition or if such condition should develop while the engine is being operated, a high voltage will be produced due to the absence of any load on the coil, and this high voltage will cause a large amount of current to flow through the rectifier in the reverse direction, resulting in the eventual puncturing of the selenium rectifier.

Therefore :

- a. Always maintain all electrical connections in the circuit in a good condition.
- b. Under no circumstances should the engine be started without the battery connected.

Checking the Condition of the Selenium Rectifier

- (1) Use service tester.
- (2) Test procedure
 - a. Set the selector switch to "Resistance $\times 100$ "
 - b. Use 6V as a power source
 - c. Short across the \oplus and \ominus leads of the tester and regulate the adjuster knob so that the tester indicator needle is pointing to "0" on the "Resistance $\times 100$ " scale. (Fig. 5-39)

(3) Inspecting the selenium rectifier

- a. Disconnect the lead wire from the rectifier terminal.
- b. Measuring in the normal direction (C50, C65, S50, S65). Connect the \oplus side of the tester "X" terminals and the white lead of the selenium rectifier with test lead, connect the \ominus side of the tester "X" terminals and the red lead of the rectifier and then measure the resistance.

The selenium rectifier is in good condition in the normal direction if it measures less than 15Ω (Fig. 5-40)

- c. Measuring in the reverse direction (C50, C65, S50, S65). Perform the measurement in the same manner as for the normal direction measurement but with the tester "X" terminals connected in reverse, the \ominus connected to the white lead of the selenium rectifier and the \oplus side to the red lead of the rectifier. The selenium rectifier is in good condition in the reverse direction if it measures over 1500Ω (Fig. 5-41)

For C50M, C65M, connect the \oplus side of the tester "X" terminals to the brown and yellow leads and the \ominus side to the red lead of the rectifier for the normal direction, and for the reverse direction, connect the \oplus side to the red lead and \ominus side to the brown and yellow leads. The selenium rectifier is in good condition if the measured resistance values are the same as above. (Fig. 5-42)

- (4) Checking the condition of the selenium rectifier as described above, the low resistance in the normal direction and a high resistance in the reverse direction indicates a good condition of the selenium rectifier.

(Note)

The service tester will give a condition indication of the selenium rectifier, however, since the true characteristics will vary with the applied voltage and wave form, an electrical test should be performed by a specialist in accordance with the specification.

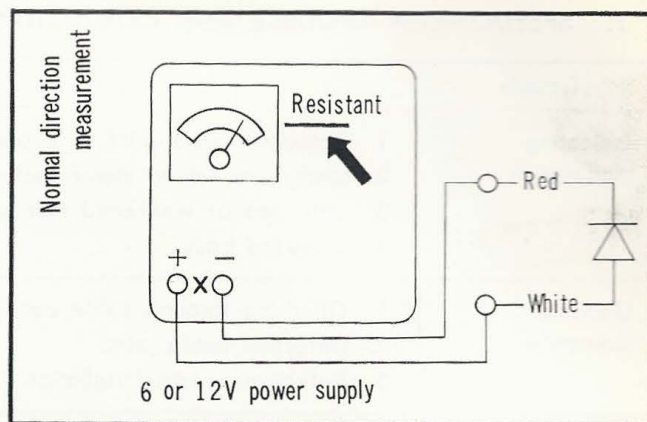

Figure 5-40. Measuring in the normal direction

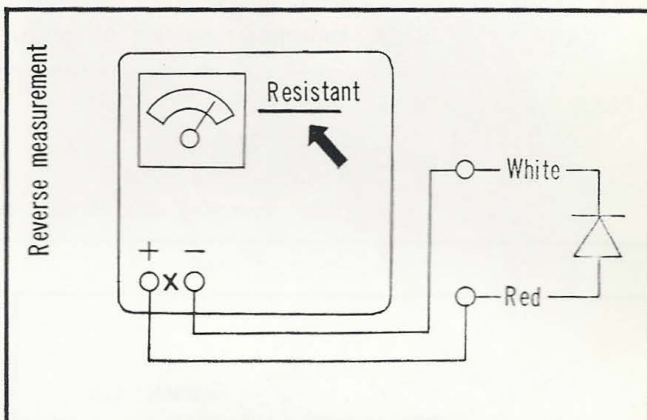

Figure 5-41. Measuring in the reverse direction

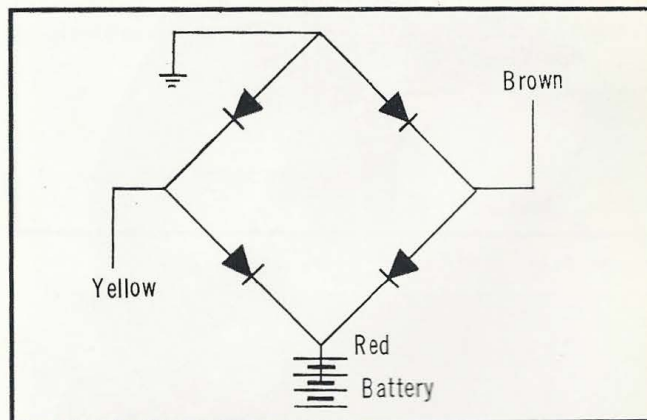

Figure 5-42. Wiring method for C50M, C65M



Figure 5-43. Speedometer

6. PERIODIC ADJUSTMENT

6.1 MAINTENANCE INSPECTION

Periodic inspections should be performed at regular schedule and designated mileages in order to obtain satisfactory service as well as to extend the useful life from your motorcycle.

A. ENGINE ADJUSTMENT

1. MEASURING COMPRESSION

A low compression pressure will result in a corresponding drop in the engine power output. Pressure leak from any cause may effect the engine speed adjustment at low speed and cause engine stall.

- a. Remove the spark plug.
- b. Insert the end of the compression gauge into the spark plug hole and hold firmly to prevent pressure from leaking. (Fig. 6-1)
- c. Operate the kick starter repeatedly several times with both the choke and throttle in the full open position.

(Caution)

- ① Make sure that the throttle and choke are fully opened, or else, a lower pressure indication will be registered on the compression gauge.
 - ② The cylinder compression pressure indication will gradually increase with each kick, therefore, continue kicking until the pressure stabilizes at the highest point.
 - ③ To obtain a true cylinder pressure indication, the measurement should be made after the engine attains operating temperature.
 - ④ Check for the proper operation of the valves.
 - ⑤ Make sure that the compression gauge is firmly fitted in the spark plug hole.
- d. The standard specified cylinder compression pressure is $12\text{kg}/\text{cm}^2$ ($172\text{ lb}/\text{in}^2$). (Fig. 6-2)
 - e. In case the compression pressure exceeds $14\text{kg}/\text{cm}^2$ ($200\text{ lb}/\text{in}^2$), it is an indication of heavy carbon deposit accumulation on the cylinder head or the piston. The deposits should be removed by disassembling the cylinder head from the cylinder.
 - f. When the compression pressure registers less than $9\text{kg}/\text{cm}^2$ ($128\text{ lb}/\text{in}^2$), it is an indication of pressure leak. First, check the tappet adjustment and see if the condition can be corrected, disassemble the engine and inspect the condition of the valves, the head gasket and piston rings.

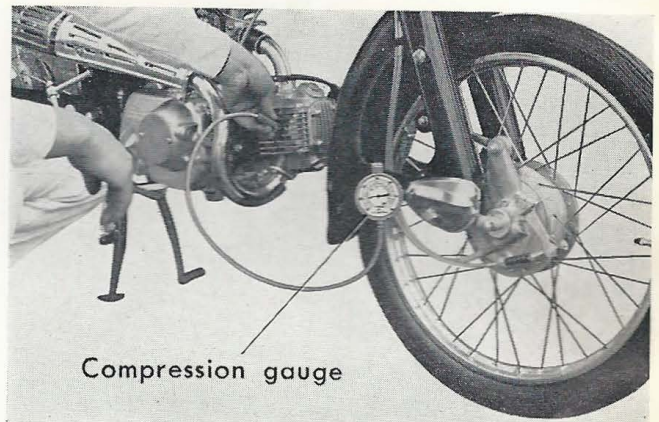

Figure 6-1. Measuring compression pressure

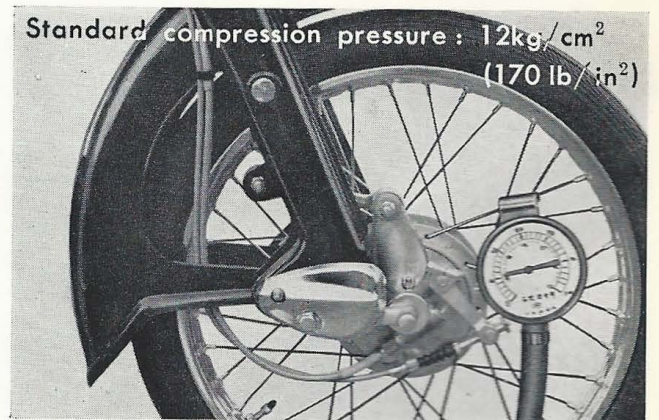

Figure 6-2. Standard compression pressure

2. TAPPET ADJUSTMENT

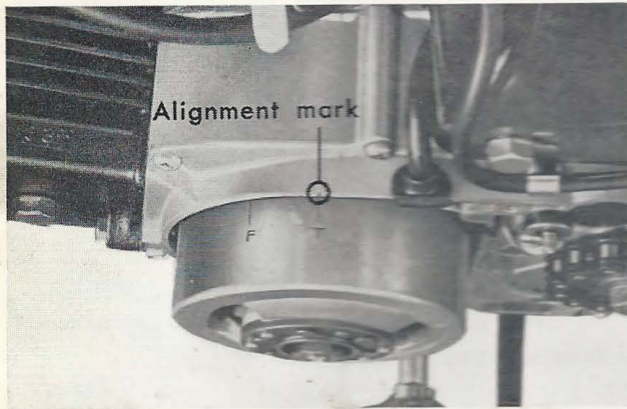

Figure 6-3. Aligning to the T timing mark

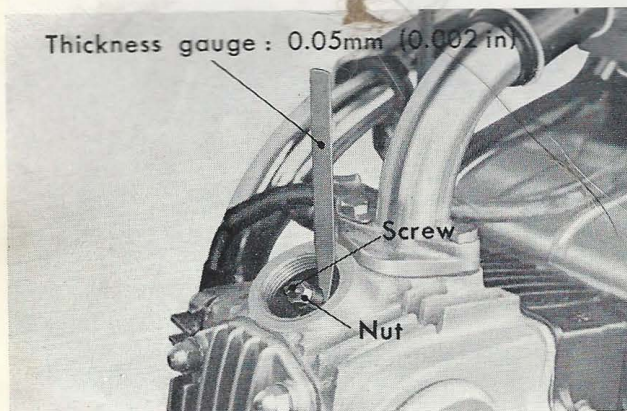

Figure 6-4. Adjusting tappet clearance

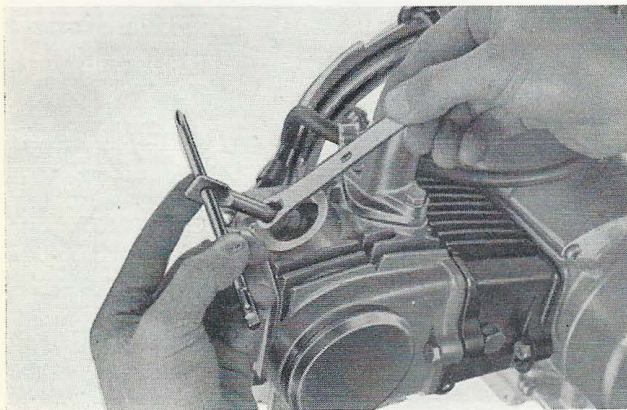

Figure 6-5. Locking the adjusting nut

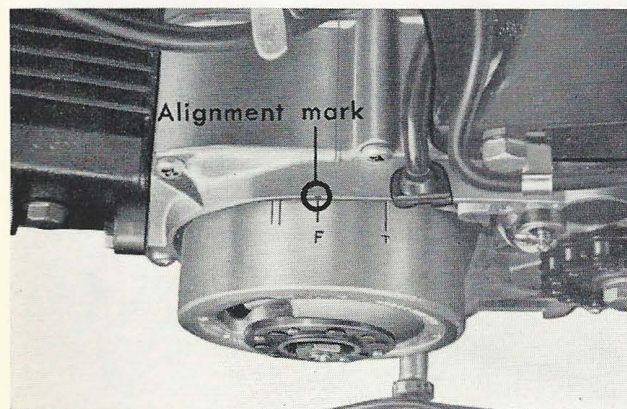

Figure 6-6. Aligning to the "F" mark

The tappet clearance will have a great deal of effect on the valve timing. If the clearance is too small, it may prevent the valve from fully closing and result in pressure leak at the valve. On the other hand, an excessive tappet clearance will produce tappet noise and result in noisy engine operation. The tappet clearance will have a varying degree of effect on the engine power output, engine operation at slow speed and engine noise.

1. Valve clearance

- a. Remove the left crankcase cover and align the timing mark "T" on the flywheel with the alignment mark on the crankcase. (Fig. 6-3)
- b. Remove the tappet adjusting cap on the cylinder head and check the clearance between the adjusting screw and the valve. (Fig. 6-4)
If the valve is actuated by the rocker arm and is in the open position, rotate the flywheel one complete turn to set the piston at top dead center of the compression stroke, and then perform the check.

2. Adjustment

Loosen the adjusting screw locking nut and make the adjustment with the adjusting screw to obtain the standard clearance of 0.05 mm (0.002 in) for both the inlet and exhaust valves.

Turn screw clockwise for closer clearance.

Turn screw counter clockwise for wider clearance.

The tappet clearance adjustment for the C50, C50M, C65, C65M, S50, S65 are identical.

(Note)

- (1) The adjustment must be made with a cold engine and the clearance measured with a thickness gauge.
- (2) When locking the adjusting screw, hold the screw to prevent its turning. (Fig. 6-5)

3. Inspection

- a. Check to make sure that the tappet clearance is within standard tolerance. Too small a clearance will cause the valve to stay open with a consequent pressure leakage and resulting in hard starting or no starting at all.
- b. Check for improper valve timing.
- c. Check for stretch in the cam chain.
- d. Check for any slippage of the timing sprocket.

3. IGNITION TIMING ADJUSTMENT

An improper ignition timing, regardless of the accuracy of the valve timing or the proper compression pressure, will not realize a satisfactory engine performance. Ignition timing out of adjustment will seriously affect engine power output as well as the fuel consumption.

1. Alignment of the "F" timing mark

- a. Remove the left crankcase cover and align the "F" marking on the flywheel to the timing mark on the crankcase. In this position, check to make sure that the spark is produced across the spark plug points. (Fig. 6-6)

Perform this test by removing and placing the spark plug on top of the cylinder head.

2. Adjustment

Make the adjustment by loosening the contact breaker lock screw.

- When the ignition timing is retarded, move the contact breaker toward the right.
- When the ignition timing is advanced, move the contact breaker toward the left.

3. Breaker point gap, 0.3 to 0.4mm (0.012-0.016 in) max.

Improper ignition timing will result in combustion to take place at the incorrect point of compression, making it impossible to obtain smooth crankshaft rotation; the throttle grip will require greater opening, consequently, the fuel consumption is increased.

Results of retarded ignition timing :

- (1) Drop in power output.
- (2) Drastic increase in fuel consumption.
- (3) Engine overheats with a possibility of piston seizure.

Results of advanced ignition timing :

- (1) Produces knocking and drop in power output. In severe cases, damage to piston, connecting rod, crankshaft may result, therefore, periodic inspection should be performed.
- (2) Upon completion of the point gap and ignition timing adjustment, check for proper operation of the spark advancer with a timing light. (Fig. 6-8)

(Use of Service Tester)

Checking the operation of the spark advancer with a tachometer

- (1) Connect the battery power, place the selector switch to "Timing".
- (2) Insert the plug end with the red and white parallel stripes of the timing light into the receptacle marked "Timing".
- (3) Screw the hexagonal connector, included with the timing light, on the top of the spark plug and after installing the rubber cap, attach the high tension cord of the timing light to the connector with the alligator clip.
- (4) Position the switch on the tachometer to "connect", insert the plug from the tachometer into the jack on the tester marked "Jack". The 6,000 rpm is read off the green zone of the meter dial. (Fig. 6-9)

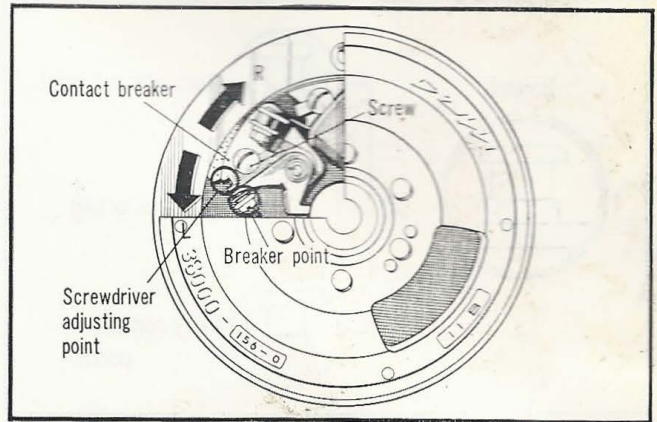

Figure 6-7. Adjusting the ignition timing

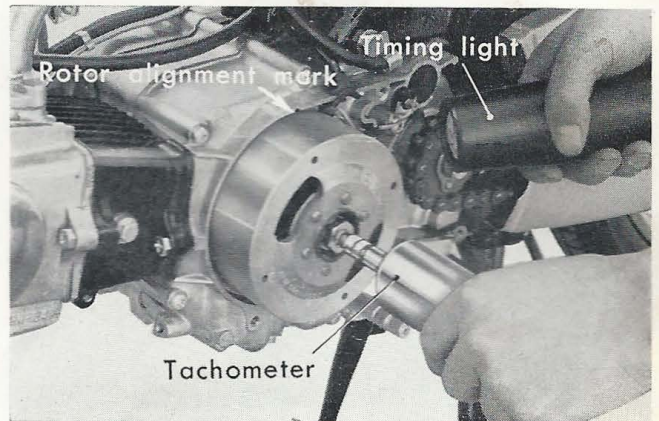

Figure 6-8. Adjusting the ignition timing advance

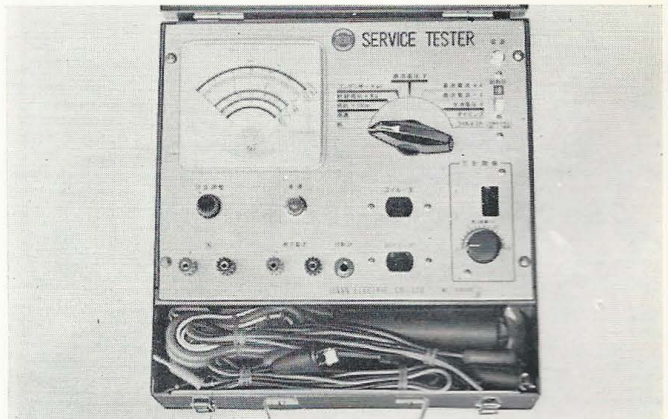

Figure 6-9. Service tester

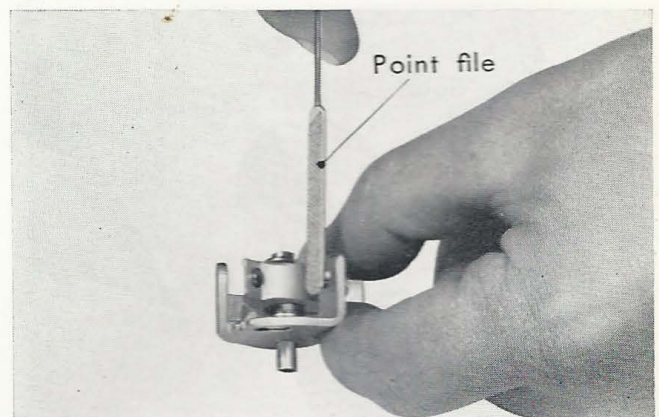

Figure 6-10. Filing breaker point contact

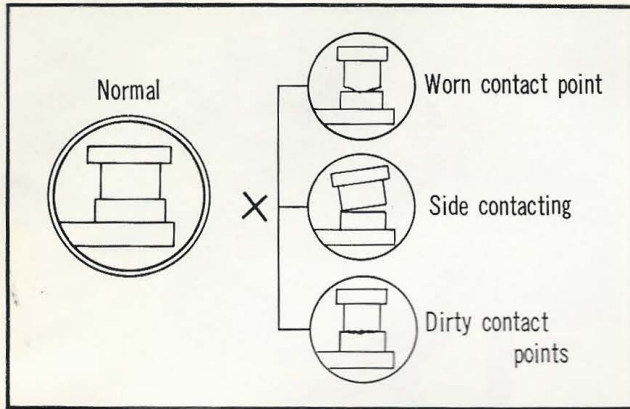

Figure 6-11. Breaker point contacting condition



Figure 6-12. Spark plug cleaner

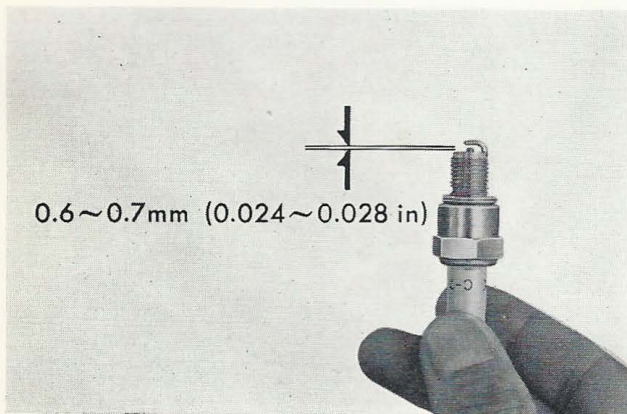

Figure 6-13. Measuring spark gap

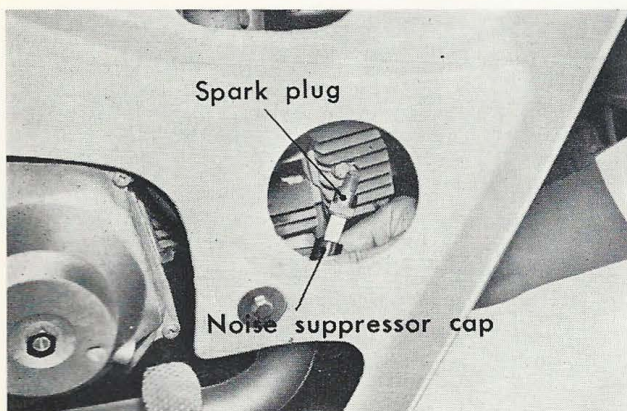

Figure 6-14. Checking spark plug

4. CONTACT POINTS

Inspect the surfaces of the contact points; if they are burnt or pitted, dress the surface with an oilstone or a point dressing file so that the center of the points are making contact. (Fig. 6-10, 6-11)

After the points have been dressed, wash in gasoline or trichloroethylene to remove all trace of oil.

Insufficient breaker point gap

- (a) The spark tends to linger, that is the interruption of the primary circuit is not completed at the points, therefore, the secondary high voltage build-up is reduced.
- (b) The closed duration of the points is longer, producing heat and resulting in damage.
- (c) In conjunction with (b) above, the points will be late in opening with a consequent delay in the ignition timing; this will cause a drop in power output.

Excessive breaker point gap

- (a) The duration that the points are closed is too short to allow for sufficient current flow in the primary circuit with a consequent low voltage build-up in the secondary or the high tension voltage circuit. This condition will cause poor engine starting, spark missing at high speed and a consequent loss of power.
- (b) Engine over-heats readily.
- (c) The ignition timing is greatly advanced.

5. SPARK PLUG ADJUSTMENT

A dirty or damaged spark plugs, or plug electrode which are eroded will not product a good strong spark, therefore, the spark plugs should be inspected periodically and cleaning and adjustments made. Spark plugs with sooty, wet electrodes, or electrodes covered with deposits will permit the high tension voltage to bypass the gap without sparking.

1. Cleaning

- a. The use of the spark plug cleaner is the recommended method of cleaning the plugs, however, a satisfactory cleaning can be performed by using a needle or a stiff wire to remove the deposits and then wash in gasoline followed by drying with a rag. (Fig. 6-12)
- b. Adjust the spark gap after cleaning. Set the gap to 0.6~0.7mm (0.024~0.028 in) by bending the electrode on the ground side. (Fig. 6-13)

Spark Plug Inspection

- a. Check the spark intensity produced between the gap of the ground and the center electrodes. (Fig. 6-14)
Blue spark.....Good condition
Red sparkPoor condition

Cause due to :

1. Low supply voltage
2. Defective ignition coil
3. Defective spark plug
4. No sparking may also be due to compression

(Caution)

- (1) Do not remove the deposits by burning
- (2) When installing the spark plugs, clean the seating area free of oil or foreign matter and install finger tight before torquing with a plug wrench.
- (3) The spark plugs can be tested after adjustment, with the plug tester. With the high tension voltage maintained constant, vary the test chamber pressure and inspect the condition of the spark.

6. FUEL SUPPLY SYSTEM

Restriction in the fuel supply system will prevent sufficient fuel flow to the carburetor and cause engine to sputter during acceleration or the engine may stall at high speed.

- a. Check for sufficient supply of fuel in the tank.
- b. Disconnect the fuel feed tube from the carburetor and check the fuel flow with the fuel cock in the ON or the RES position. (Fig. 6-15)
- c. If the fuel flow is insufficient, remove the fuel tank from the body and clean internally. When the flow is still inadequate, remove the fuel cock, disassemble and clean.

(Caution)

- ① The insufficient fuel flow may be caused by the plugged vent hole in the filler cap as well as the restriction in the fuel line. (Fig. 6-16, 6-17)
 - ② The fuel cock is switched to RES (reserve) from the ON position when the fuel tank becomes empty. The reserve fuel supply contains approximately 0.8 l ($\frac{1.7 \text{ U.S. pt}}{1.4 \text{ Imp pt}}$) for the C50, C50M, C65, C65M and approximately 1 l ($\frac{2.1 \text{ U.S. pt}}{1.6 \text{ Imp pt}}$) for the S50 and S65, sufficient to travel approximately 50 km (31 mi) and 60 km (37 mi) respectively.
- d. Fuel strainer cleaning
- The accumulation of dirt and water in the fuel cock strainer cup will cause a restriction in fuel flow, resulting in drop in engine speed and malfunction of the carburetor. Clean the cock, strainer and the filter screen at periodic interval.

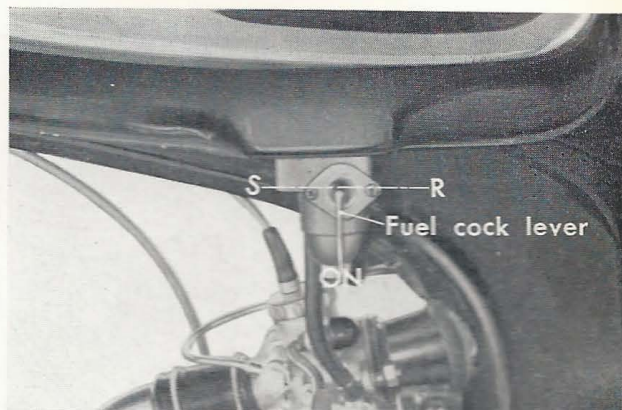

Figure 6-15. Fuel cock lever

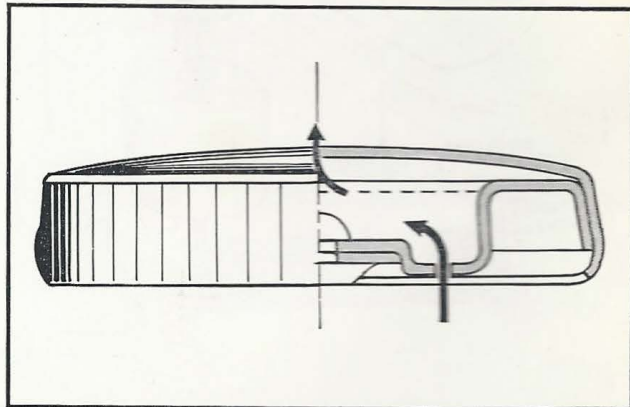

Figure 6-16. Fuel tank cap cross section (C65, C65M)

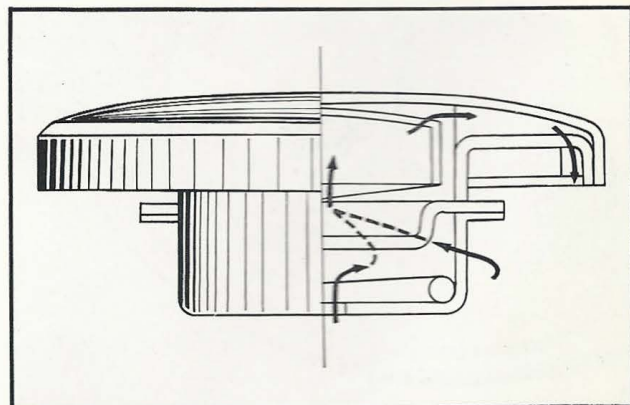

Figure 6-17. Fuel tank cap cross section (S50, S65)

7. FUEL STRAINER CLEANING

The foreign substances contained in the fuel passes through the fuel line from the fuel tank and enters the strainer cup. The foreign substances and water, if not arrested will enter the cylinder and causes engine failure.

1. Cleaning

- a. Set the fuel cock lever to the STOP position.
- b. Remove the strainer cup.
- c. Clean inside the strainer cup and filter screen. (Fig. 6-18)

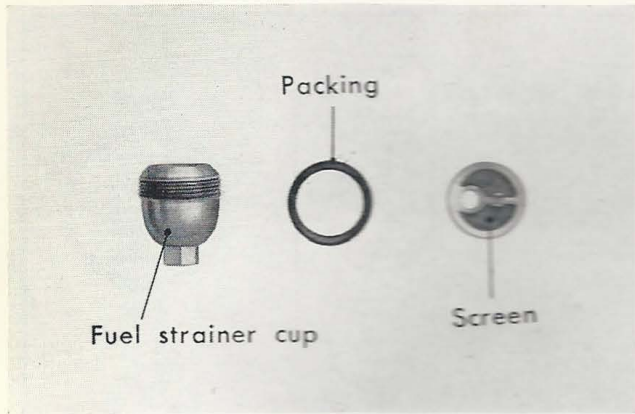

Figure 6-18. Cleaning fuel strainer

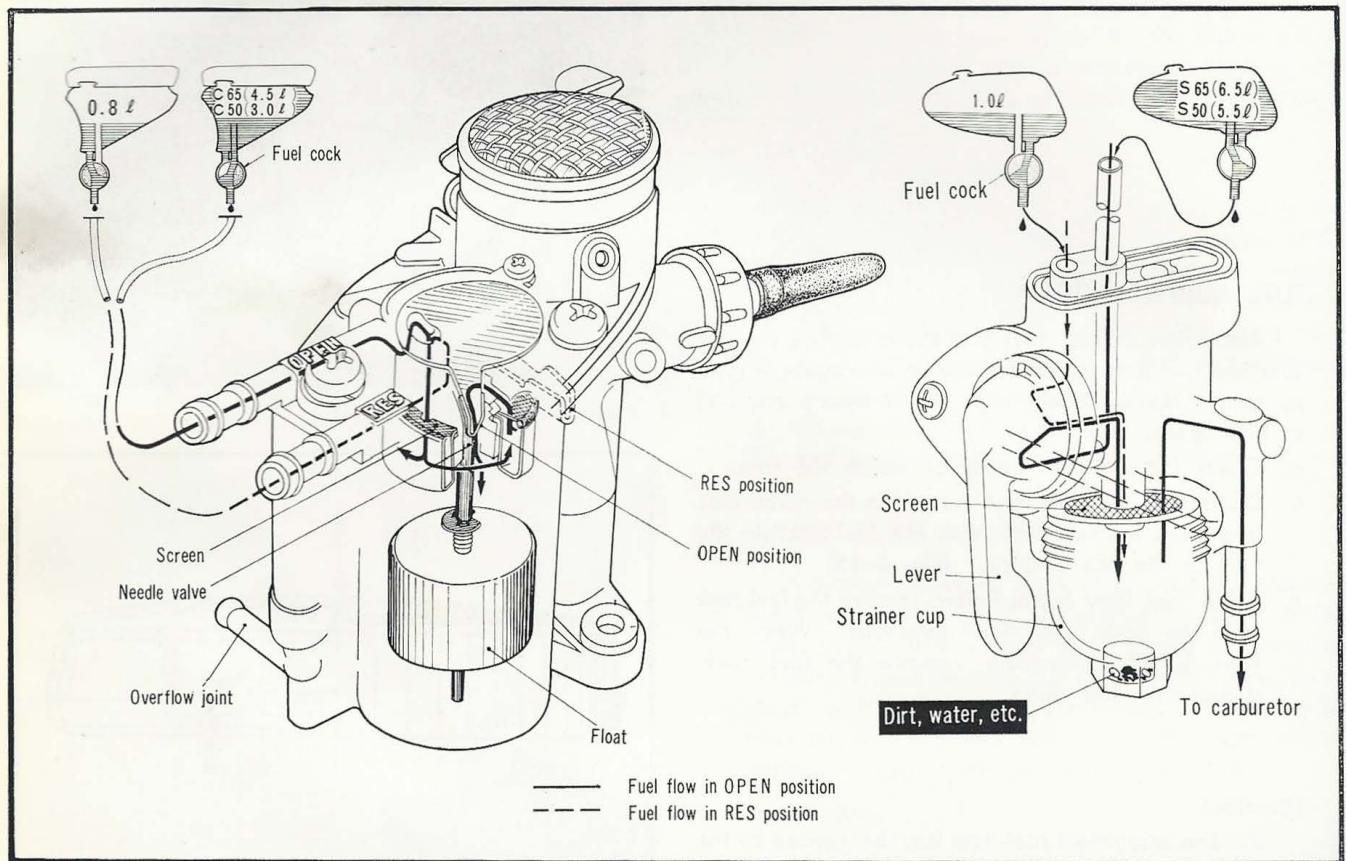

Figure 6-19. Fuel flow through the fuel cock

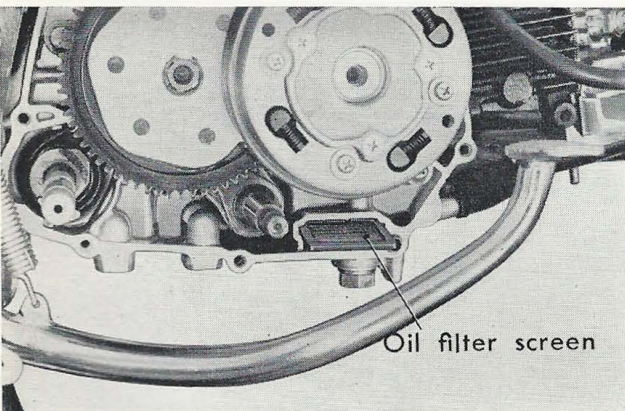

Figure 6-20. Cleaning oil filter screen

8. OIL FILTER SCREEN CLEANING

The engine oil is filtered through a system of double filters before being supplied to the various parts of the engine. When the impurities have accumulated in the filters to prevent its proper function, the oil supply to the various parts are starved and eventually result in seizure and damage to the engine. It is therefore important that the filters be cleaned periodically.

1. Cleaning

- (1) Remove the kick pedal. (for S50 and S65, remove the oil pipe).

- (2) Remove the right crankcase cover, pull out the oil screen and wash in gasoline. (Fig. 6.20)

(Caution)

- (1) Install the oil filter screen with the narrow tapered side toward the inside and the fin on the filter screen toward the bottom.

9. AIR CLEANER CLEANING

An air cleaner clogged with dust restricts the free passage of inlet air and result in power loss or drop in acceleration, therefore, to assure proper performance, periodic cleaning of the air cleaner should be performed.

1. Removal (C50, C50M, C65, C65M)

- Loosen the cap nut on top of the front cover and remove the air cleaner cover, then loosen nut on the inside and detach the air cleaner.
- For models S50 and S65, remove the air cleaner cover on the center right side, loosen the screw and remove the air cleaner. (Fig. 6-21)

2. Cleaning

- Tap the cleaner lightly to remove the dust and then blow dry compressed air from the inside or use a brush. (Fig. 6-22)

(Caution)

- The air cleaner is made of paper and if torn or damaged, replace with a new element.
- Oil or water on the cleaner element will render it ineffective and will cause dust to enter the engine cylinder, resulting in increased cylinder wear.

10. CLUTCH ADJUSTMENT

(S50, S65)

The function of the clutch is to transmit or disengage the rotary power produced by the engine to the transmission. If the gear is engaged without the clutch being completely disengaged, the vehicle will start moving with a jolt or the engine will stall out. On the other hand, if the clutch is slipping, the speed of the motorcycle will lag in relation to the engine speed.

1. Lever play (S50, S65)

There should be 1 to 1.5cm (0.4~0.6 in) of free play in the clutch lever before the clutch starts to disengage. (Fig. 6-23)

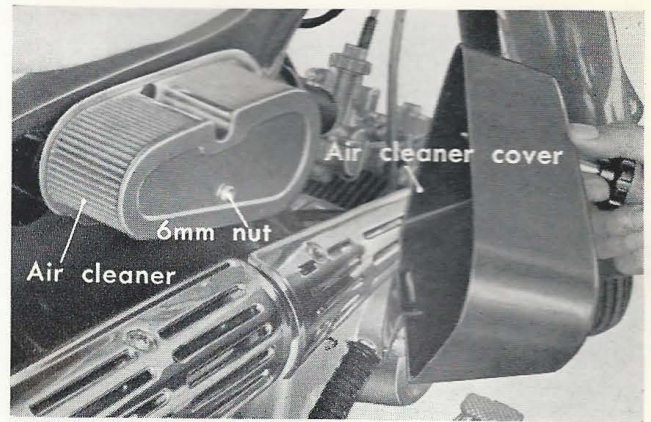

Figure 6-21. Removing air cleaner cover (S50, S65)

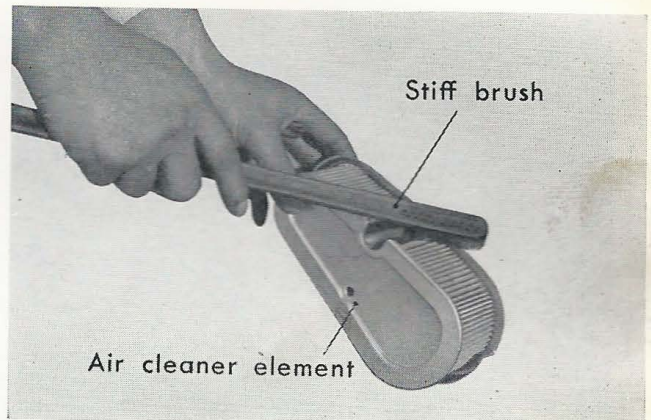

Figure 6-22. Cleaning air cleaner element

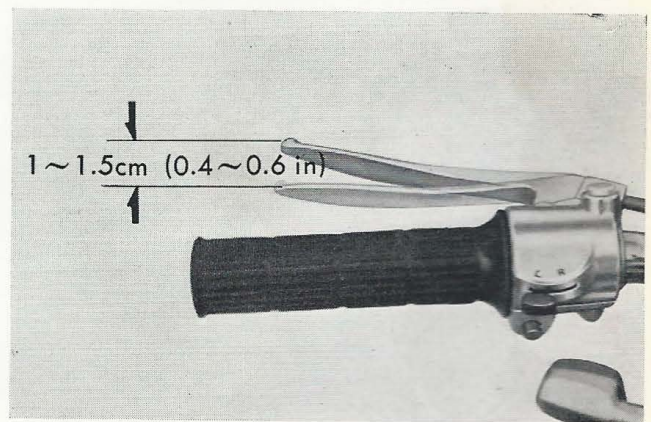

Figure 6-23. Clutch lever free play

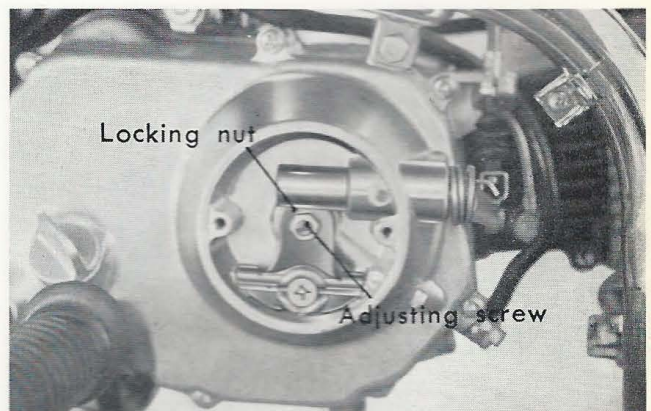

Figure 6-24. Adjusting the clutch (S50, S65)

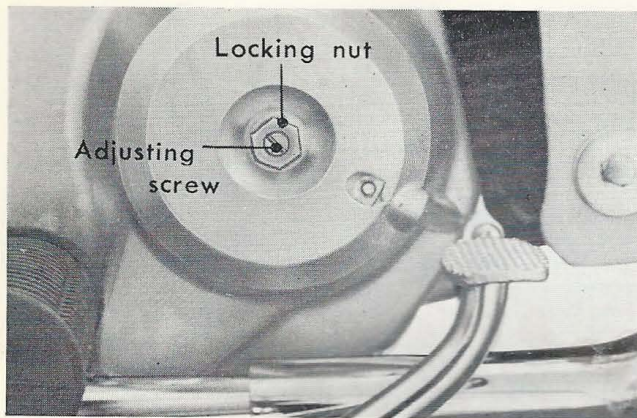

Figure 6-25. Adjusting the clutch (C50, C50M, C65, C65M)

2. Adjustment

Loosen the lock nut and turn the adjusting screw.

C50, C50M, C65, C65M :

Turn to the right to increase the lever free play.

Turn to the left to decrease the lever free play.

S50, S65...

Turn to the left to increase the lever free play.

Turn to the right to decrease the lever free play.

(1) For model C50, C50M, C65 and C65M check for slippage of the clutch and the disengaging action.

(2) For adjusting the clutch on model S50, S65 remove the clutch cover, loosen the locking nut and adjust with the screw. (Fig. 6.24)

The adjustment of the clutch may also be performed at the adjuster on the clutch cable. On C50, C50M, C65 and C65M model, the adjustment can be made without removing the clutch cover. (Fig. 6-25)

3. Inspection (S50, S65)

(1) Check by kick starting and see if the engine readily starts.

(2) Start the engine, grasp the clutch lever and check to see if the motorcycle starts moving or the engine stalls when the gear is shifted into low.

(3) The motorcycle should start moving smoothly as the clutch lever is released gradually while increasing the engine rpm.

11. CARBURETOR CLEANING AND ADJUSTMENT

A dirty carburetor or carburetor out of adjustment will cause poor engine performance. As an example, a carburetor set to a lean fuel air mixture will cause the engine to overheat while a rich mixture will cause engine to run sluggish. An overflowing of fuel from the carburetor is a possible fire hazard, therefore, periodic cleaning and adjustment should be performed.

1. Cleaning

a. Disassemble the carburetor and wash the parts in gasoline.

b. Blow out the nozzles with compressed air and after cleaning and reassembly, make the adjustment.

2. Idle adjustment

The idle adjustment is performed with both the throttle stop screw and the air screw by the following procedure. (Fig. 6-26, 6-27)

(a) Set the throttle stop screw to the specified idling speed (1000~1200 rpm)

(b) Next, adjust the air screw by turning slowly in both direction to obtain the highest engine speed.

Turning the screw in will produce a rich fuel mixture.

Turning the screw out will produce a lean fuel mixture.

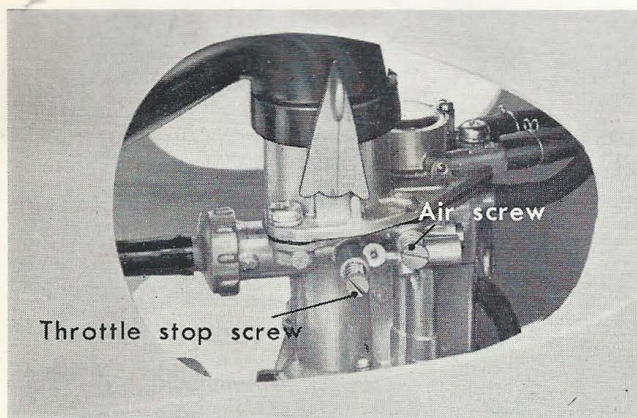

Figure 6-26. Adjusting the carburetor (C50, C50M, C65, C65M)

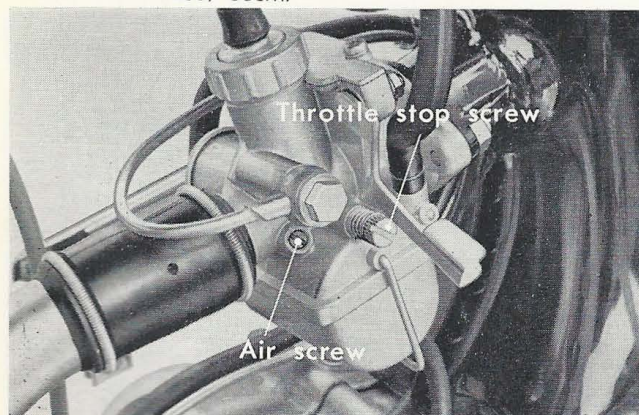

Figure 6-27. Adjusting the carburetor (S50, S65)

- (c) Reduce the engine speed which has gone up in (2) to the specified RPM by regulating the throttle stop screw.
- (d) At this throttle stop screw setting, recheck the carburetor adjustment by manipulating the air screw.
- (e) After the idling adjustment has been completed, check the carburetor by snapping the throttle and also check the throttle response. The air screw should be $\frac{1}{8}$ to $\frac{1}{4}$ turn of the specified setting.

(Note)

All adjustment should be made after the engine has attained operating temperature.

B. LUBRICATING

The purpose of lubrication is to prevent direct surface to surface contact of the moving parts by providing a film of oil between the surfaces and thereby, reducing friction and preventing wear. It also serves to cool the parts from the heat produced by friction.

Further, the lubricant penetrates between the piston and cylinder to form an oil film which act as a seal to maintain the cylinder pressure.

1. PARTS NOT REQUIRING PERIODIC OIL CHANGE OR LUBRICATION

There are some parts which only require lubrication whenever the parts are disassembled for repair or replacement.

Steering stem steel balls and cone race	} Grease
Throttle grip	
Main stand	

2. ENGINE OIL CHANGE

Change oil at 300 km (185 mi) driving and at every 1000 km (620 mi) thereafter.

1. Oil Change

- a. Remove the oil cap and drain the engine completely of oil by unscrewing the plug at the bottom of the engine. (Fig. 6-28, 6-29)

(Note)

The oil should be drained while the engine is still warm.

- b. The proper oil level is indicated by the oil between the level markers on the gauge when checked without screwing the cap down.

(Fig. 6-30)

Oil capacity

0.8 ℓ (1.7 U.S. pt, 1.4 Imp pt)

After overhauling the engine, fill crankcase with 0.8 ℓ ($\frac{1.7 \text{ U.S. pt}}{1.4 \text{ Imp pt}}$) of oil, however, during oil changes refill according to the level gauge.

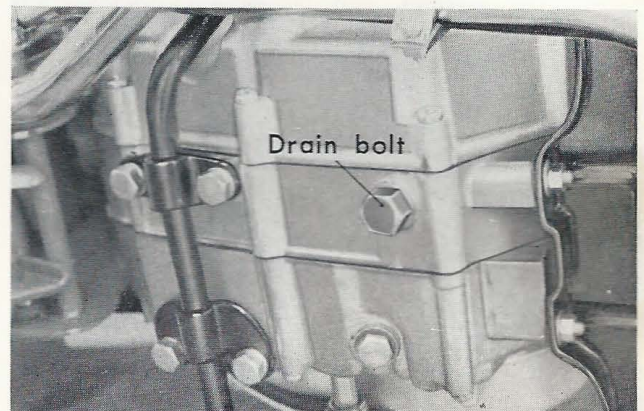

Figure 6-28. Removing drain bolt

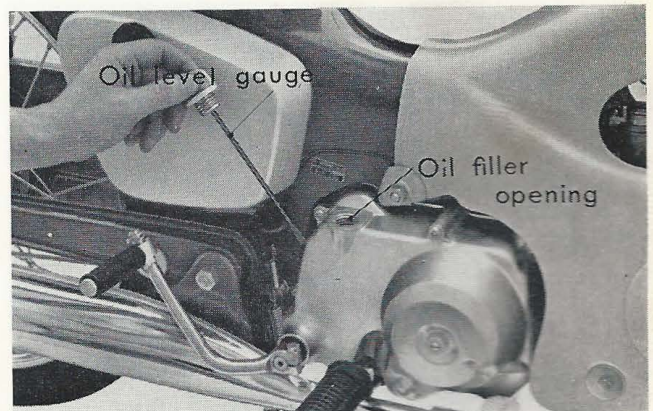

Figure 6-29. Oil cap

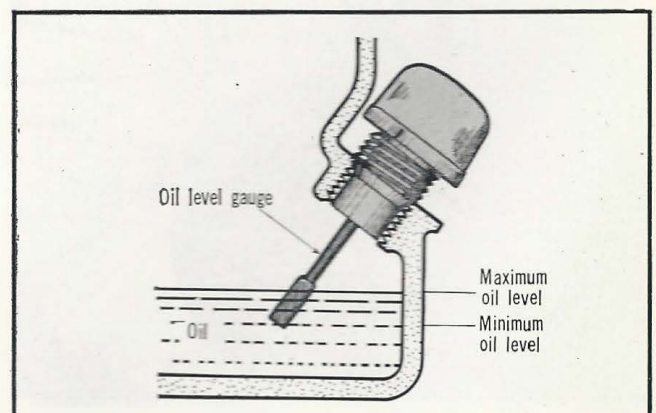

Figure 6-30. Oil level gauge



Figure 6-31. Ultra oils

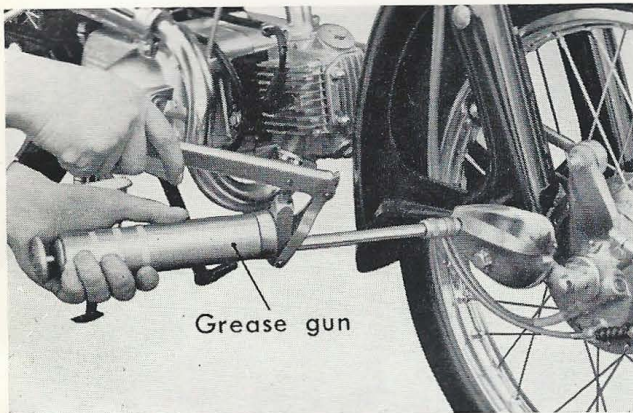

Figure 6-32. Greasing

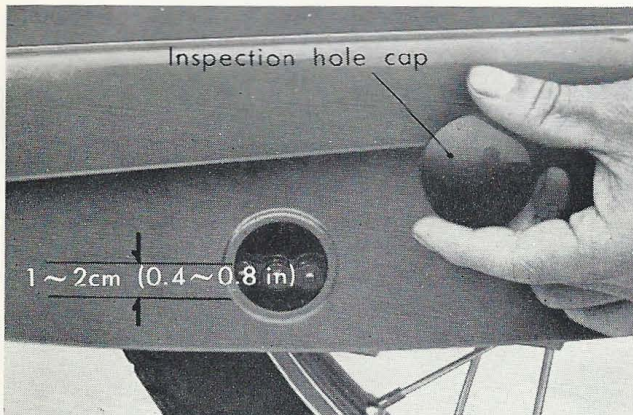

Figure 6-33. Inspecting drive chain tension

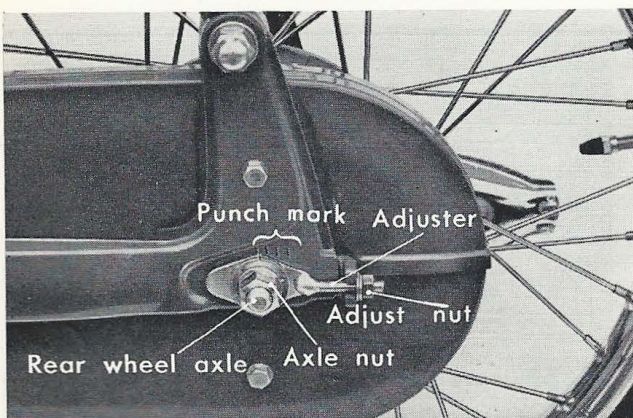

Figure 6-34. Adjusting the drive chain

Oil Brand and Grade

Honda ultra oil is recommended. The grade of oil for the season is shown on the R. crankcase cover. When the Honda ultra oil is not available, use the oil corresponding to MS. DG or DM in the A.P.I. service classification.

(Fig. 6-31)

Under 0°C (32°F)	SAE 10W
0° ~ 15°C (32 ~ 59°F)	SAE 20W
over 15°C (59°F)	SAE 30

(Note)

- (1) Oil plays a prominent role in the life and the trouble free performance of an engine, therefore, it is very important that the oil change be performed periodically and refrain from using dirty oil over a long period. The more frequent the oil change, the better it is for the engine.
- (2) When refilling or adding oil, it should not be filled above the specified level. Overfilling will cause oil pumping and loss of power.
- (3) Use only recommended oil.

3. GREASING

1. Lubrication

Apply grease to all grease nipples with grease gun until the grease is forced out at the clearances. (Fig. 6-32)

Use multi-purpose NLGI No. 2 grease.

(Note)

- (1) Clean the dirt from the nipple before greasing.
- (2) Fit the grease gun nozzle securely to the nipple when greasing.
- (3) Exercise care and do not permit the grease to become contaminated with dirt, dust or mix with air.

C. DRIVE CHAIN ADJUSTMENT

An excessively slack drive chain will cause chain to whip, whereas an over-tension condition will produce resistance, resulting in lowering the power output at the rear wheel. Always maintain the chain at the specified tension.

1. Tension Checking Procedure

- a. Remove the inspection cover on the chain case and check to see if the total vertical slack of the chain is between 1~2cm (0.40~0.78 in). (Fig. 6-33)
- b. Perform adjustment by loosening the axle nut and sleeve nut and then adjust with the adjuster nut. (Fig. 6-34)
Turn to the right to decrease chain slack.
Turn to the left to increase chain slack.

(Caution)

The adjusters should be at the same adjuster marks for both the right and left sides.

- c. Periodically clean and lubricate the chain.
Lack of oil will cause the chain links to bind and cause undesirable effect on the sprocket.

D. BRAKE ADJUSTMENT

Brakes are the life-line of the rider, therefore, do not neglect to perform the periodic inspection, daily inspection and pre-riding inspection.

1. FRONT BRAKE ADJUSTMENT

1. Lever free play

- The free play of the brake lever, that is, the distance between the normal attitude and the point where the brake starts to take hold should be 2~3cm (0.73~1.12 in). (Fig. 6-35)
- Adjustment is made by the adjusting nut. (Fig. 6-36)
Turn to the right to decrease the free play.
Turn to the left to increase the free play.

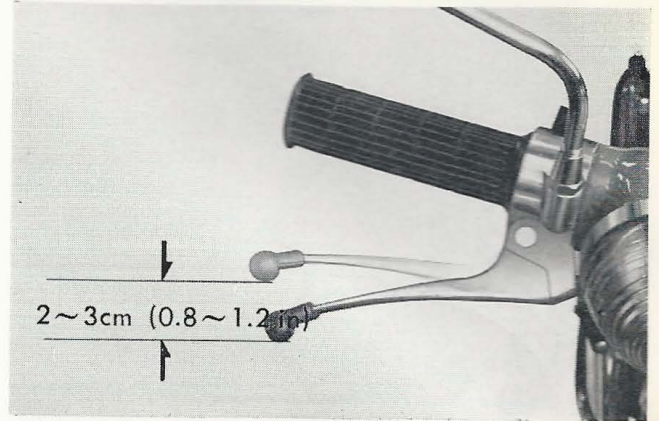

Figure 6-35. Free play of front brake lever



Figure 6-36. Adjusting front brake lever

2. REAR BRAKE ADJUSTMENT

1. Pedal free play

- The free play of the brake pedal, that is the distance between the normal attitude and the point where the brake starts to take hold should be 2~3cm. (0.78~1.12 in). (Fig. 6-37)
- Adjustment is made by the adjusting nut. (Fig. 6-38)
Turn to the right to decrease pedal play.
Turn to the left to increase pedal play.
- When the braking stroke is small, the following condition is apparant.
 - Too small a clearance between brake panel and shoe.
 - Loss of tension in the brake spring.
 - Brake lining damaged due to overheating.

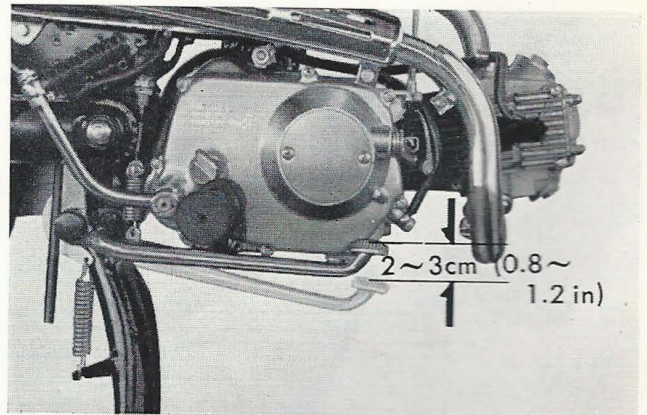

Figure 6-37. Free play of brake pedal



Figure 6-38. Adjusting rear brake

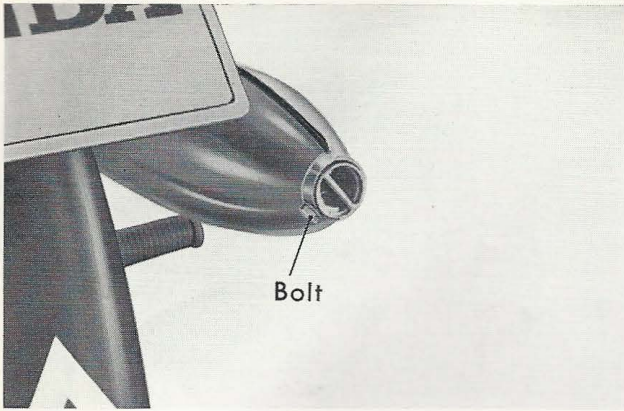

Figure 6-39. Removing diffuser pipe

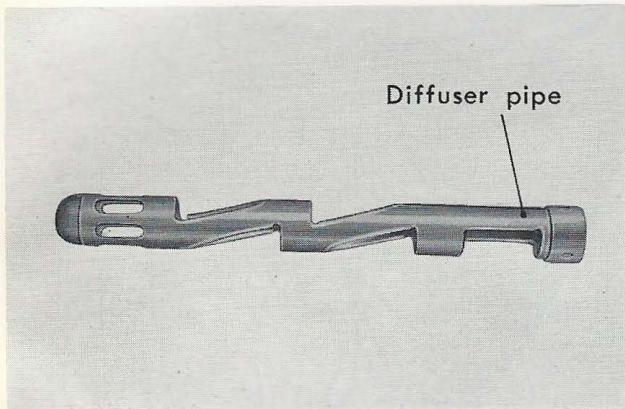

Figure 6-40. Cleaning diffuser pipe



Figure 6-41. Retorquing spokes

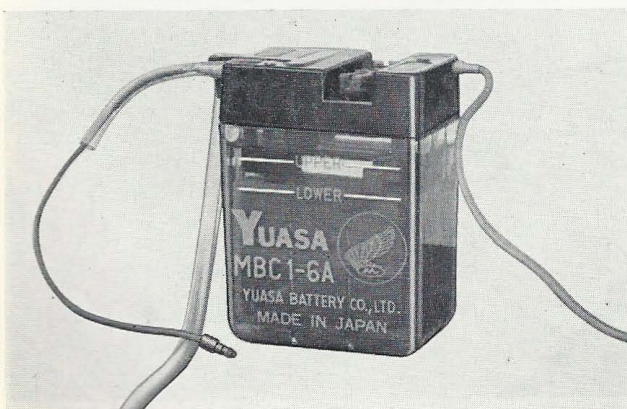

Figure 6-42. Battery

E. MUFFLER CLEANING

The function of the muffler is to muffle the noise of the exhaust gases as it is emitted from the combustion chamber. In the process, the carbon particles in the gas accumulates on the muffler and the diffuser pipe. Excess accumulation of the carbon will restrict the flow of the exhaust gas, creating back pressure which effects the engine performance by lowering the power output.

1. Cleaning

- a. Remove the diffuser pipe locking bolt and pull out the diffuser pipe (Fig. 6-39)
- b. Tap the pipe lightly to remove the carbon and then wash in solvent or gasoline (Fig. 6-40) The clogging of the diffuser pipe will cause a drop in the engine power output. A loose connection at the gasket joint will produce undesirable noise from leaking exhaust gas.

F. SPOKE TORQUING

Riding with loose spoke will place an ununiform loading on the rim as well as on the remaining spokes, therefore, the spokes should be inspected frequently and retorqued when they become loose.

Raise the wheel off the ground and check each spoke for tightness, any spoke which are noticeably loose should be torqued to the same value as the remaining spokes so that the spokes are all of uniform torque. Use the spoke nipple tool and torquing wrench. (Fig. 6-41)

G. BATTERY INSPECTION

Loss in battery electrolyte occurs after long use and should be replenished periodically. When the electrolyte level drops to the point where the plates are exposed, it will result in rapid discharge to the battery. The battery, should always be maintained at the proper electrolyte level.

1. Electolyte Level

- a. Remove the battery box, disconnect the battery cable from the battery, unfastened the battery band and remove the battery. (Fig. 6-42) The standard battery used is the MBC 1-6. (Mfg. by Yuasa Battery Co.)

b. Always maintain the electrolyte level above the lower electrolyte level marking on the battery. When replenishing, add distilled water to raise the electrolyte level to the upper marking. (Fig. 6-43)

c. Replenish by removing the battery cap at the top and add the distilled water. All three battery cells should be filled to the same level.

2. Damaged and Dirty Battery Cable Connector

Inspect the connectors for cleanliness and damage. Clean the dirty connectors or replace damaged connectors before making connection and apply a coating of grease or vaseline on the connectors to prevent corrosion.

3. Specific Gravity

Check the specific gravity of all three cells of the battery with a hydrometer, if it measures below 1.200, the battery should be charged.

A fully charged battery should indicate a specific gravity of 1.280 at electrolyte temperature of 20°C (68°F). The specific gravity will vary somewhat with the temperature at the rate of 0.0007 specific gravity variation for each 1°C (1.8°F) change in temperature. A rise in temperature will cause a decrease in specific gravity and visa versa. (Fig. 6-44)

(Caution)

- ① Do not add any sulfuric acid to the distilled water when replenishing.
- ② When the drop in electrolyte level is excessive, check the discharge rate of the battery.
- ③ Excercise care not to pinch the battery cable when making the battery installation.
- ④ Also, make sure that the vent tube is not pinched
- ⑤ When the temperature drops, the capacity of the battery will lowers and cause hard starting. In such a case, store the motorcycle in a warm place.

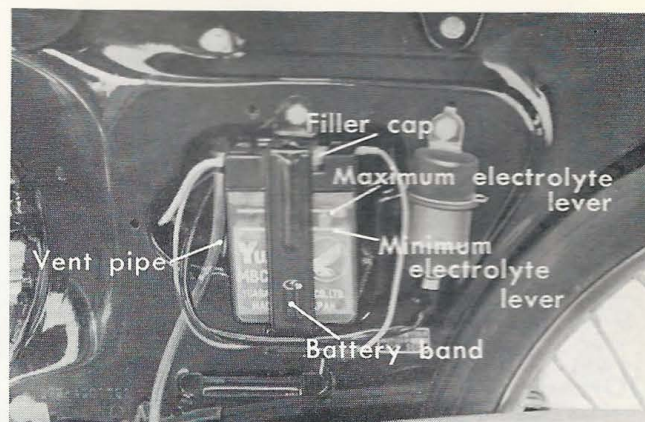

Figure 6-43. Battery electrolyte level

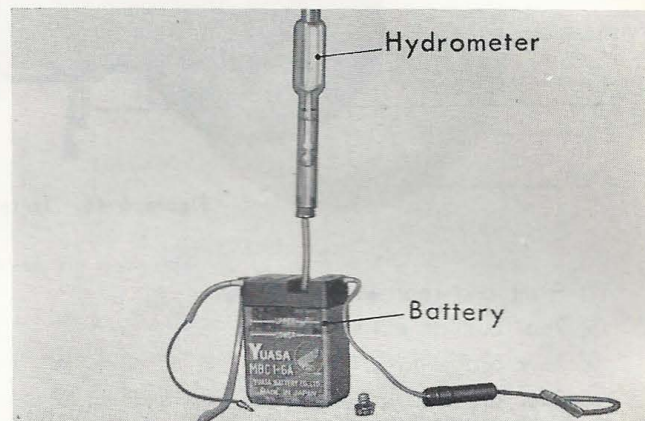

Figure 6-44. Measuring specific gravity

H. SECURITY INSPECTION OF PARTS (C50, C50M, C65, C65M)

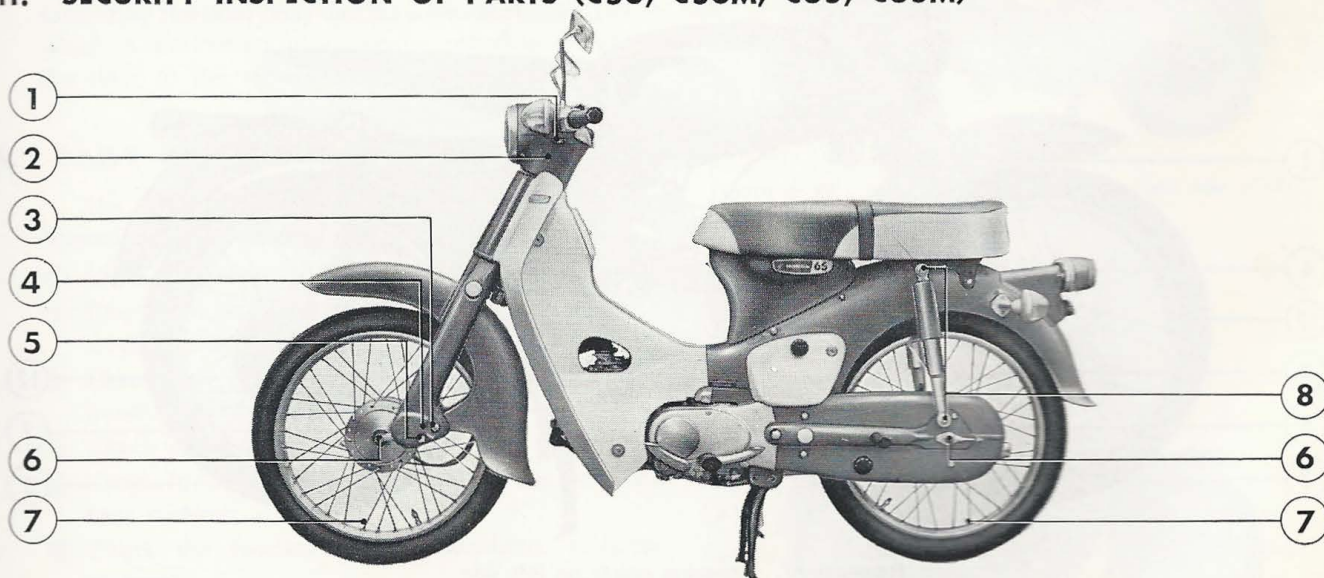

Figure 6-45. Torquing points on left side

- ① Handle installation nuts.
- ② Steering stem nut.
- ③ Front arm pivot bolts.

- ④ Front cushion lower bolt.
- ⑤ 8×42, hex bolts.
- ⑥ Front and rear axle nuts.

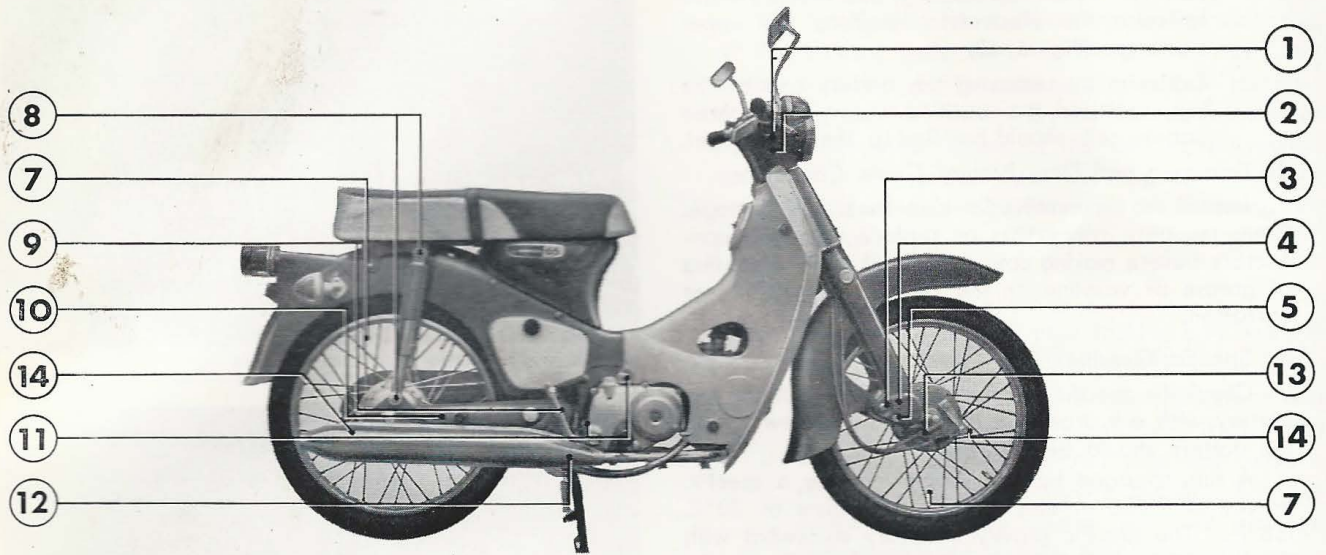

Figure 6-46. Torquing points on right side

- ⑦ Front and rear wheel spokes.
- ⑧ Rear cushion installation nuts.
- ⑨ Rear brake pivot bolt nut.
- ⑩ Rear brake torque link latch clip and nut.
- ⑪ Engine mounting bolts and nuts.
- ⑫ Rear brake pivot pipe and clip.
- ⑬ Speedometer cable gearbox assembly nut.
- ⑭ Front and rear brake adjust nuts.

I. SECURITY INSPECTION OF PARTS (S50, S65)

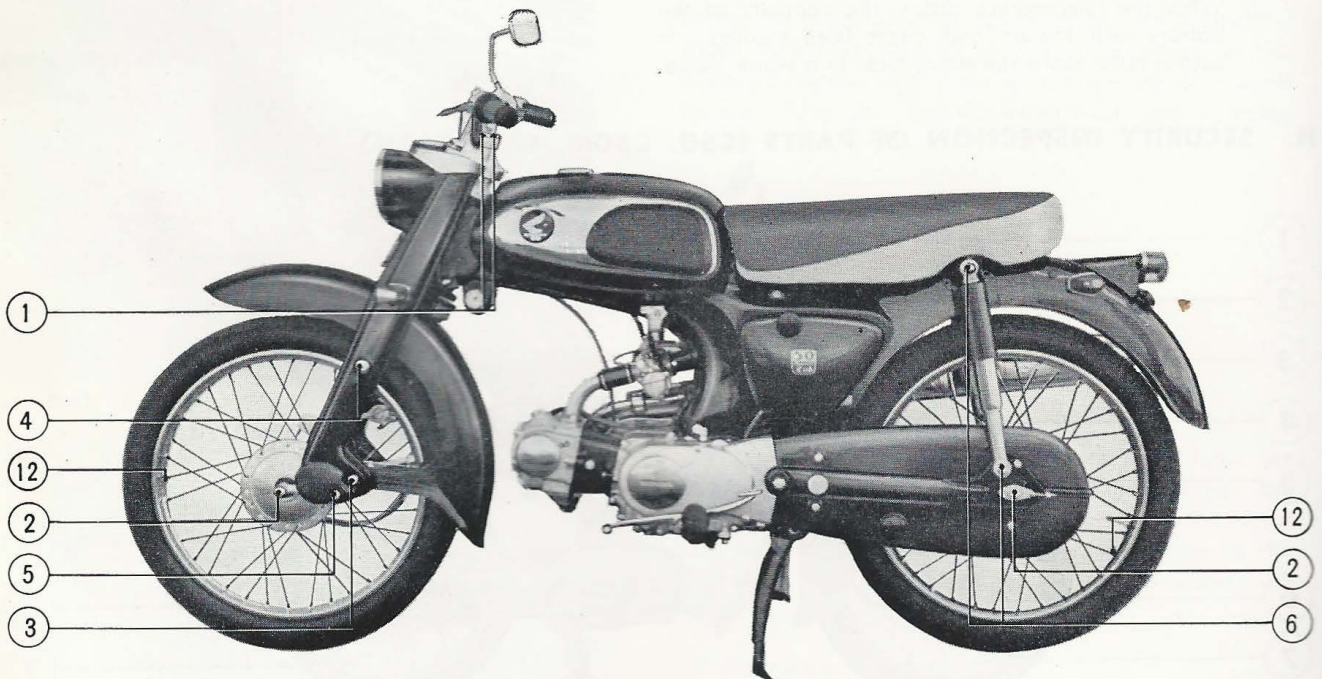

Figure 6-47. Torquing points on left side

- ① Steering stem nut and handle installation nuts.
- ② Front and rear axle nuts.
- ③ Front arm pivot bolts.
- ④ Front cushion upper bolts.
- ⑤ Front cushion lower bolts.
- ⑥ Rear cushion installation nuts.

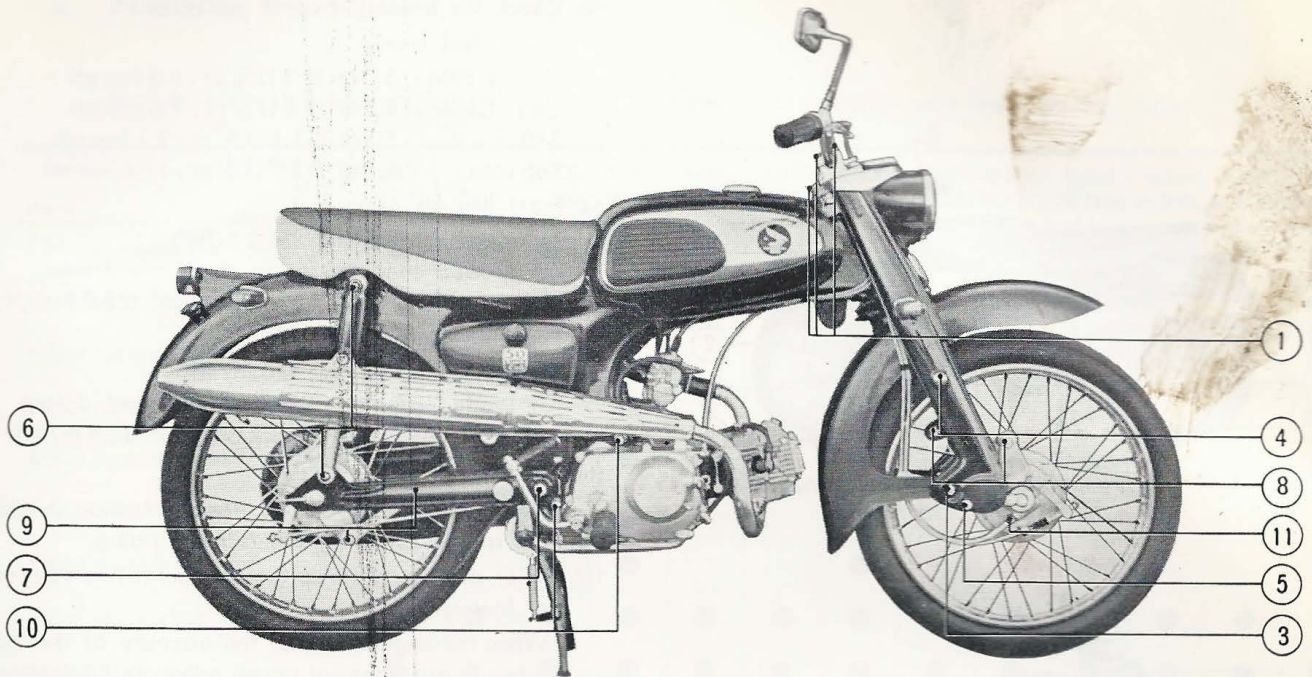

Figure 6-48. Torquing points on right side

- ⑦ Rear fork pivot bolt nuts.
- ⑧ Front brake torque link locking nuts.
- ⑨ Rear brake torque link latch clip and nut.
- ⑩ Engine mounting bolts and nuts.
- ⑪ Speedometer cable gearbox assembly nuts.
- ⑫ Front and rear wheel spoke.

6.2 PERIODIC INSPECTION AND SERVICING

It is of utmost importance to perform periodical inspection and servicing so that troubles can be prevented and the motorcycle maintain in the best of operating condition. The inspection is classified into two types, namely, the pre-riding inspection performed by the rider daily and the periodical inspection which is performed at a regular schedule either by the rider or the service shop.

A. DAILY INSPECTION

The following items of inspection should be performed as a matter of habit. (Fig. 5.50, 5.51)

- ① Check for excessive loosenes or sway of the handle.
- ② Check for proper free play of the front brake lever, 2~3cm (0.78~1.12 in) is normal.
- ③ Check for proper free play of the rear brake pedal, 2~3cm (0.78~1.12 in) is normal.
- ④ Check clutch release operation.
- ⑤ Check for looseness and oil leaks in the front and rear cushions.
- ⑥ Check the function of the headlamp, taillamp, stoplamp.
- ⑦ Check the horn for sound.
- ⑧ Check operation of the turn indicator.
- ⑨ Correct level and condition of the engine oil (0.8 ℓ (1.7 U.S. pt) (1.4 Imp pt)).

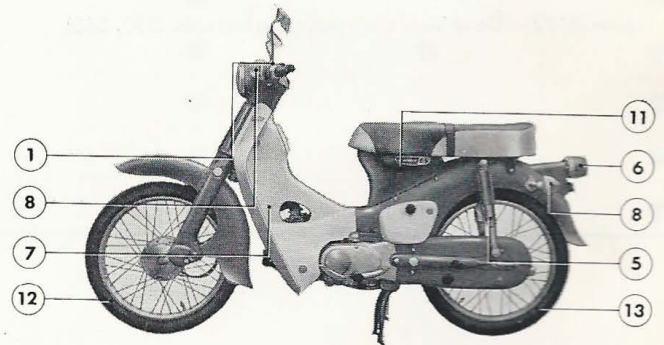

Figure 6-49. Daily inspection points on left side (C50, C50M, C65, C65M)

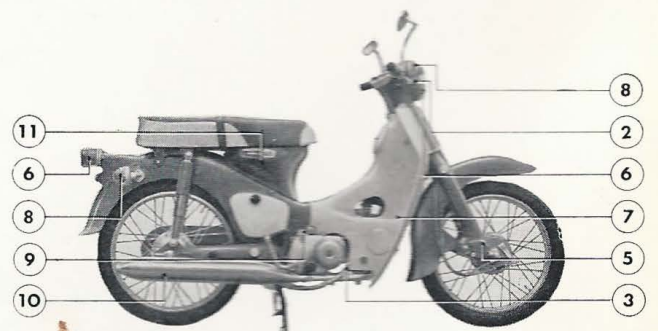

Figure 6-50. Daily inspection points on right side (C50, C50M, C65, C65M)



Figure 6-51. Daily inspection points on right side (S50, S65)



Figure 6-52. Daily inspection points on left side (S50, S65)

- ⑩ Check for unusual exhaust gas color.
- ⑪ Check fuel level.
C50, C50M : 3.0 lit (6.3 U.S. pt : 5.3 Imp pt)
C65, C65M : 4.5 lit (9.5 U.S. pt : 7.5 Imp pt)
S50 : 5.5 lit (11.6 U.S. pt : 9.7 Imp pt)
S65 : 6.5 lit (13.7 U.S. pt : 11.4 Imp pt)
- ⑫ Front tire air pressure.
Normal.....1.7kg/cm² (24.2 lb/in²)
For loaded condition or for high speed riding
.....1.8kg/cm² (25.7 lb/in²)
- ⑬ Rear tire air pressure.
Normal.....2.1 kg/cm² (30 lb/in²)
For loaded condition or for high speed driving
.....2.3kg/cm² (32.8 lb/in²)

(Note)

After inspecting the above items, attention should be paid to the following points when riding.

- (1) After starting, warm up the engine for two minutes at low speed.
When the engine is cold, the viscosity of the oil is heavy and does not permit adequate lubrication to all the parts.
- (2) Do not race the engine needlessly.
- (3) Refrain from abrupt acceleration or braking, tight cornering.
- (4) Change oil every 500 km (310 mi) during winter driving or when used mostly for short trips.
- (5) Check battery electrolyte level weekly without fail. Under the following conditions, checks should be made at a more frequent intervals.
 - a. When riding more than 50 km (31 mi) daily.
 - b. Riding in mountainous area.
 - c. More frequent inspection is necessary when riding at high speed.

B. PERIODIC INSPECTION

Periodic inspection and servicing should be performed in accordance with the following table.

Items	Distance Km Miles		300	1,000	2,000	3,000	4,000	5,000	6,000	7,000	8,000	9,000	10,000	11,000	12,000
	(180)	(620)	(1,240)	(1,860)	(2,480)	(3,100)	(3,720)	(4,340)	(4,960)	(5,580)	(6,200)	(6,820)	(7,440)		
Change engine oil	●	●	●	●	●	●	●	●	●	●	●	●	●	●	●
Greasing				●					●			●			●
Adjust ignition timing				●					●			●			●
Adjust valve clearance	●			●					●			●			●
Adjust cam chain	●			●					●			●			●
Adjust clutch	●			●					●			●			●
Adjust carburetor				●					●			●			●
Adjust drive chain	●	●	●	●	●	●	●	●	●	●	●	●	●	●	●
Adjust front brake	●	●	●	●	●	●	●	●	●	●	●	●	●	●	●
Adjust rear brake	●	●	●	●	●	●	●	●	●	●	●	●	●	●	●
Clean spark plug				●					●			●			●
Clean oil filter	●								●						●
Clean air cleaner				●					●			●			●
Clean fuel strainer									●						●
Clean muffler				●					●			●			●
Inspect tightness of nuts and bolts	●								●						●
Inspect suspensions				●					●			●			●
Inspect lights, horn and speedometer				●					●			●			●

7. TROUBLE SHOOTING

It is most important that the cause of any trouble be located as soon as possible and the proper corrective action taken so that the serviceable life of the engine will be extended.

In the following table are listed the troubles, probable causes and the corrective actions.

1. MAIN ENGINE TROUBLE

Troubles	Probable causes	Corrective action
Engine will not continue running.	<ol style="list-style-type: none"> 1. Clogged fuel cock. 2. Plugged vent hole in fuel tank cap. 3. Improper tappet clearance. 4. The carburetor to intake manifold connecting tube damaged or leaking air at the joints. 5. Improper oil level 	Clean and inspect.
Engine malfunctions after warm-up.	<ol style="list-style-type: none"> 1. Defective spark plug 2. Defective ignition coil 3. Incorrect flat level 	1. Overheated spark plug, replace with plugs of correct heat range
Excessive smoke at high engine speed. (oil pumping condition)	<ol style="list-style-type: none"> 1. Oil being pumped into the combustion chamber due to excessively worn or damaged cylinder, piston, rings and burned during combustion. 	By diagnosing the noise, rebore and/or replace the parts as required.
Noise produced near the top of the engine	<ol style="list-style-type: none"> 1. Worn piston and cylinder The clearance between the piston and cylinder is increased causing the piston skirt to slap against cylinder wall during combustion. 2. Worn connecting rod large end produces knocking 3. Tappet noise 	<ol style="list-style-type: none"> 1. Inspect and rebore cylinder and replace worn parts. 2. Replace connecting rod, large end bearing and crank pin. 3. Adjust to proper specification.
Overheating engine	<ol style="list-style-type: none"> 1. Carbon deposit accumulation 2. Dirty or fouled spark plugs 3. Improper type spark plugs or gap 4. Insufficient lubrication to drive chain or chain tension too tight. 5. Oil level too low, poor or improper grade oil 6. Improper distributor point gap clearance, dirty, burnt 7. Excessive carbon accumulation in combustion chamber 	<ol style="list-style-type: none"> 1. Disassemble and clean 2. Clean, dry fouled plugs. Inspect carburetor if plugs continues to foul. 4. Adjust periodically, lubricate 7. Adjust periodically
Engine does not start (lack of compression)	<ol style="list-style-type: none"> 1. Foreign object caught between valve and valve seat 2. Tappet stuck open 4. Ignition timing out of adjustment 5. Blown fuse 	Reference

Engine suddenly stalls while running	<ol style="list-style-type: none"> 1. Clogged fuel cock 2. Fuel passage in the carburetor clogged 3. Dirty spark plugs (heavy carbon deposit or wet plug) 4. Ignition timing out of adjustment 5. Blown fuse 	<ol style="list-style-type: none"> 1. Disconnect the fuel line and check the fuel flow 5. If the fuel is blown, the pilots lamps will not light up
Oil becomes emulsified (especially during winter)	<ol style="list-style-type: none"> 1. Water mixed with oil 2. Use of improper type oil 3. Clogged breather pipe 	<ol style="list-style-type: none"> 2. Use genuine Honda Ultra Oil or equivalent oils (Caution) The oil, even though clean in appearance, may decompose due to extended use and become thin, resulting in loss of lubricating properties. Should be replaced.
Increased fuel consumption. Condition: ① Low exhaust noise, low back pressure at muffler ② Low compression noticeable when kick starting.	<ol style="list-style-type: none"> 1. Clogged air cleaner 2. Distributor point gap out of adjustment, dirty, burnt 3. Excess accumulation of carbon in cylinder exhaust port or inside muffler. 4. Ignition timing retarded 5. Worn cylinder, piston, piston ring. 	<ol style="list-style-type: none"> 1. Clean air cleaner element 2. Adjust gap clearance, rework or replace burnt points 4. If ignition timing is retarded, the distributor points will open after the timing mark "F" has been passed. Adjust to proper setting
Insufficient engine rpm.	<ol style="list-style-type: none"> 1. Fuel passage clogged 2. Defective spark plug (fouled) 3. Clogged muffler 4. Clogged air cleaner 5. Ignition timing out of adjustment. 	<ol style="list-style-type: none"> 1. When the fuel passage in clogges, the spark plugs will be dry. 4. If the air cleaner is clogged, engine will not develop high RPM and the exhaust smoke becomes dark. Clean the air filter element periodically.
Poor throttle response (check first to see that the throttle cable is properly adjusted)	<ol style="list-style-type: none"> 1. Clogged air cleaner 2. Clogged exhaust port or exhaust pipe 3. Ignition timing out of adjustment 4. Tappet clearance out of adjustment 	
Distributor points burnt	<ol style="list-style-type: none"> 1. Points covered with oil 2. Improper ignition timing 3. Defective condenser 4. Condenser in poor condition 	Test condenser by method described below.

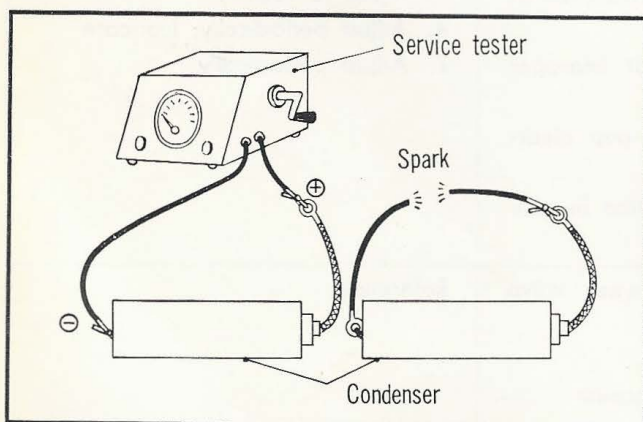

Figure 7-1. Measuring condenser capacity

Condenser Test Method

After taking the resistance value with the megger, use a copper wire to short across the terminals, a good strong spark should be produced at the instance the leads are contacted.

Condenser Measurement

With the distributor points open, measure the resistance between the primary terminal and the outer shell, a good condenser should measure at least 5 megohm resistance at standard temperature.

The condenser is defective if it measures below 1 megohm.

Determine the condition of the condenser by the above method.

(Caution)

A loosely installed condenser or dirty terminal will cause ignition to malfunction.

2. CARBURETOR TROUBLE

Trouble	Probable cause	Corrective action
1. Fuel overflow (related symptom) <ul style="list-style-type: none"> • Poor idling • Poor performance in all speed • Excessive fuel consumption • Hard starting • Low power output • Poor acceleration 	1. Contaminated fuel	1. Remove float chamber cover (C50, C50M, C65, C65M) <ul style="list-style-type: none"> a. Remove locking clip and disassemble the float chamber (S65). b. Check for any dirt lodge in the valve seat, remove dirt by blowing with compressed air or by unscrewing the valve seat, and clean. c. Reassemble after cleaning in gasoline.
	2. Damaged valve or valve seat	2. Replace both the valve and valve seat with new parts.
	3. Punctured float	3. Remove the float chamber cover, take out the float and check for fuel in the float. (Checking procedure) <ul style="list-style-type: none"> • Shake the float • Immerse the float in hot water 90-95°C (194~263°F) for approximately 50, 60 seconds, bubbles can be observed if the float is punctured.
	(S 65) 4. Float arm lip bent	4. Straighten the arm lip if bent and use the fuel level gauge to obtain the proper fuel level.

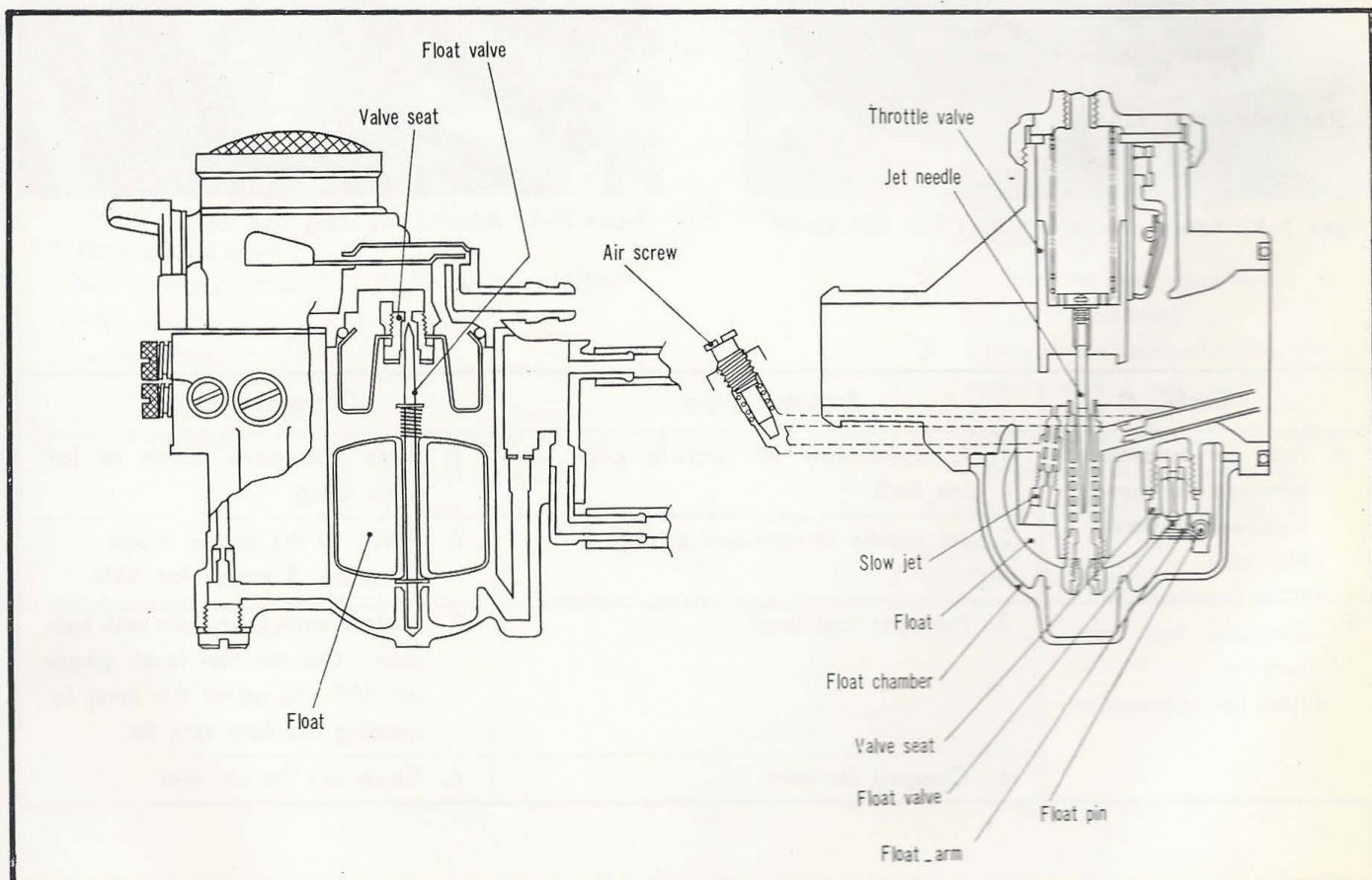

Figure 7-2. Carburetor cross section diagram

Trouble	Probable cause	Corrective action
2. Poor idling (related symptom) <ul style="list-style-type: none"> • Poor performance at slow speed • Poor speed transition • Poor response to throttle snapping • Poor performance at intermediate speed 	1. Air screw improperly adjusted	1. Turn the air screw lightly to full close and check to see if the air screw was properly adjusted. Back off $1\frac{1}{4} \pm \frac{1}{8}$ turn from full close. ($1\frac{1}{2}$ turn for S65). Start the engine and turn the air screw in both direction not more than $\frac{1}{4}$ turn ($\frac{1}{2}$ turn for S65) and set at the point where the engine rpm is highest (smooth)
	2. Throttle stop screw out of adjustment	2. Back off the throttle stop screw all the way and check for proper operation of the throttle, turn the stop screw in until the proper rpm is obtained.
	3. Clogged slow jet (including pilot jet)	3. Unscrew the plug, remove the pilot jet (slow jet for S65), check for any dirt, blow out with compressed air if dirty. Remove the slow jet and clean in the same manner.

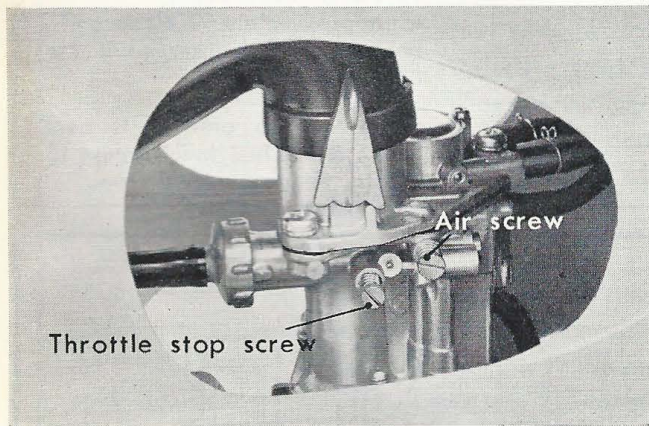

Figure 7-3. Adjusting the idling (C50, C50M, C65, C65M)

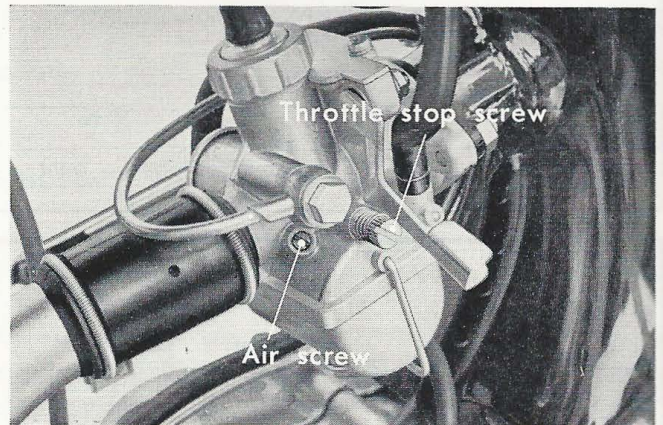

Figure 7-4. Adjusting the idling (S50, S65)

Trouble	Probable cause	Corrective action
3. Poor performance at intermediate speed (related symptom) <ul style="list-style-type: none"> • Flat spot • Poor acceleration • Excessive fuel consumption • Poor speed transition 	1. Clogged slow jet (include pilot jet for S65)	1. Same corrective action as for poor idling
	2. Jet needle at improper setting	2. Adjust to the proper stage (3 stages, 2 stages for S65)
	3. Improper fuel level	3. Replace worn jet needle with new part. Use the fuel level gauge for S65 and adjust the level by bending the float arm lip.
	4. Clogged air vent	4. Clean out the air vent

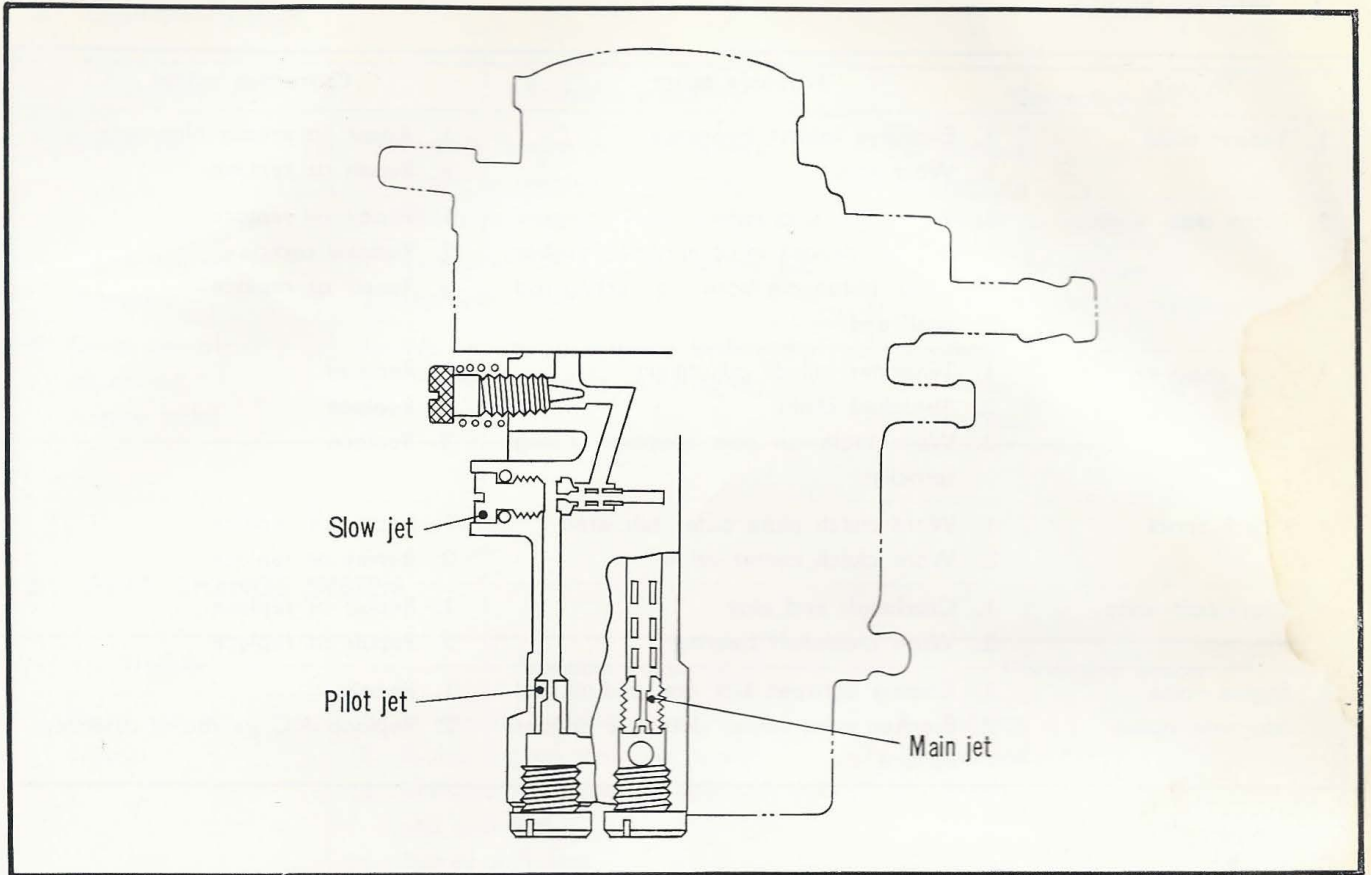

Figure 7-5. Carburetor cross section diagram

Trouble	Probable cause	Corrective action
4. Poor high speed performance (related symptom) <ul style="list-style-type: none"> • Loss of power • Poor acceleration • Black exhaust smoke • Poor engine performance 	1. Loose main jet or clogged with dirt 2. Clogged air vent tube 3. Choke closed 4. Fuel cock improperly positioned (S65) 5. Loose jet needle	1. Remove main jet and clean, install and tighten securely. 2. Clean out vent tube 3. Open the choke to full OPEN position 4. Position the fuel cock lever to full OPEN position. 5. If jet needle locking clip is broken, replace with a new part.
5. Hard starting	1. Excessive use of choke 2. Fuel overflow 3. Fuel cock in closed position	1. Start engine with choke valve fully open (clean spark plug) 2. Same corrective action as 1 above 3. Open fuel cock

3. ENGINE NOISE

Trouble	Probable cause	Corrective action
1. Tappet noise	<ol style="list-style-type: none"> Excessive tappet clearance Worn tappet 	<ol style="list-style-type: none"> Adjust to proper clearance Repair or replace
2. Piston slap	<ol style="list-style-type: none"> Worn piston, cylinder Carbon deposit in combustion chamber Worn piston pin bore, connecting rod small end 	<ol style="list-style-type: none"> Repair or replace Remove carbon Repair or replace
3. Cam chain noise	<ol style="list-style-type: none"> Tensioner out of adjustment Stretched chain Worn teeth on cam sprocket, timing sprocket 	<ol style="list-style-type: none"> Readjust Replace Replace
4. Clutch knock	<ol style="list-style-type: none"> Worn clutch plate outer tab area Worn clutch center spline 	<ol style="list-style-type: none"> Repair or replace Repair or replace
5. Crankshaft noise	<ol style="list-style-type: none"> Crankshaft end play Worn crankshaft bearing 	<ol style="list-style-type: none"> Repair or replace Repair or replace
6. Engine noise (magneto noise)	<ol style="list-style-type: none"> Chafing between kick arm and oil seal Breaker point noise, defective slipper surface 	<ol style="list-style-type: none"> Repair Replace A.C generator assembly

4. STEERING SYSTEM

Trouble	Probable cause	Corrective action
1. Handle operates heavy	<ol style="list-style-type: none"> Overtorqued steering cone race Damaged steering steel balls Bent steering stem 	<ol style="list-style-type: none"> Readjust Replace Repair
2. Front or rear wheel shimmy	<ol style="list-style-type: none"> Loose bearing in front or rear wheel Bent rim on front or rear wheel Loose spoke Worn rear fork pivot bushing Twisted frame Drive chain adjuster out of adjustment Defective tire 	<ol style="list-style-type: none"> Check for wear and replace as required Straighten by loosening or tightening the spokes. Replace if uncorrectable Replace Repair or replace Adjust to proper value Replace
3. Pulls to one side	<ol style="list-style-type: none"> Right and left cushions not balanced, front or rear. Misalignment of front and rear cushions Bent front fork Bent rear fork Bent front axle Loose component in steering system 	<ol style="list-style-type: none"> Replace Replace Repair Repair Repair Repair

5. CLUTCH SYSTEM

Trouble	Probable cause	Corrective action
1. Clutch slips	<ol style="list-style-type: none"> 1. Loss of tension in clutch springs 2. Worn or warped clutch plate 3. Worn or warped clutch friction disc 	<ol style="list-style-type: none"> 1. Replace 2. Replace 3. Repair or replace
2. Clutch will not disengage	<ol style="list-style-type: none"> 1. Excessively worn clutch friction disc 2. Improper adjustment 	<ol style="list-style-type: none"> 1. Repair or replace 2. Adjust to proper specification
3. Clutch out of adjustment (engine stalls)	<ol style="list-style-type: none"> 1. Warped clutch plate or friction disc 2. Uneven tension of clutch spring 	<ol style="list-style-type: none"> 1. Repair 2. Measure tension and repair or replace

6. GEAR CHANGE SYSTEM

Trouble	Probable cause	Corrective action
1. Gears will not engage	<ol style="list-style-type: none"> 1. Broken lug on shift drum 2. Broken lug on shift arm broken 3. Unsmooth movement between shift drum and shift fork 4. Broken shift fork 5. Broken lug on counter shaft second gear 6. Broken lug on main shaft second and third gear 	<ol style="list-style-type: none"> 1. Replace 2. Replace 3. Repair 4. Replace 5. Replace 6. Replace
2. Gear change pedal not returning	<ol style="list-style-type: none"> 1. Broken shift return spring 2. Gear shift spindle rubbing against case or cover 	<ol style="list-style-type: none"> 1. Replace 2. Repair
3. Gear jumps out of engagement	<ol style="list-style-type: none"> 1. Worn lug on counter shaft second gear 2. Worn lug on main shaft second and third gear 3. Worn or bent shift fork 4. Broken or loss of tension of shift drum stopper spring. 	<ol style="list-style-type: none"> 1. Repair or replace 2. Repair or replace 3. Replace 4. Replace

7. SUSPENSIONS

Trouble	Probable cause	Corrective action
1. Soft suspension	1. Loss of spring tension 2. Excessive load	1. Replace
2. Hard suspension	1. Ineffective front cushion damper 2. Ineffective rear cushion damper	
3. Suspension noise	1. Cushion case rubbing 2. Interference between cushion case and spring 3. Damaged cushion stopper rubber 4. Insufficient spring damper oil (front and rear)	1. Inspect cushion spring and case 2. Repair 3. Replace 4. Replace

8. BRAKE SYSTEM

Trouble	Probable cause	Corrective action
1. No range of adjustment	1. Worn brake shoe 2. Worn brake cam slipper 3. Worn brake cam	1. Replace 2. Replace 3. Replace
2. Unusual noise when applied	1. Worn brake shoe 2. Foreign object lodged in brake lining 3. Pitted brake drum surface 4. Worn brake panel bushing	1. Replace 2. Remove foreign object 3. Repair 4. Replace
3. Ineffective braking	1. Inoperative front brake cable 2. Loose brake rod 3. Improper brake shoe contact 4. Dirt or water inside the brake 5. Oil or grease on brake lining	1. Remove foreign object from cable and inspect for bends 2. Inspect and repair 3. Inspect and repair 4. Inspect and repair 5. Inspect and repair

9. DRIVE CHAIN

Trouble	Probable cause	Corrective action
1. Drive chain stretch rapid	1. Excessive load applied to chain (during riding or gear change) 2. Due to oil leak, excessive lubrication	1. Correct riding technique 2. Perform proper lubrication periodically
2. Excessively worn sprocket	1. Driving with worn sprocket 2. Sprocket mal fitted to drive chain	1. Clean sprocket area 2. Replace with proper sprocket

8. SPECIFICATIONS & PERFORMANCES

SPECIFICATIONS

	C50	C50M	C65, C65M	S65	S50
Name of Motorcycle	Honda 50	Honda 50	Honda 65	Honda 65	Honda 50
Model type	C50	C50M	C65 (C65M)	S65	S50
Type of vehicle	Motorcycle	Motorcycle	Motorcycle	Motorcycle	Motorcycle
Classification	Light motorcycle	Light motorcycle	Light motorcycle	Light motorcycle	Light motorcycle
Riders	1	1	2	2	1
Manufacturer	Honda Motor Co., Ltd., Suzuka Factory	Same as left	Same as left	Same as left	Same as left
Address	Hirata-cho, Suzuka City, Mie Prefecture, Japan	Same as left	Same as left	Same as left	Same as left
Frame Type	C50	C50	C65	S65	S50
Manufacturer	Honda Motor Co., Ltd., Suzuka Factory	Same as left	Same as left	Same as left	Same as left
Dimension, mm					
Overall length	1795 (70.67 in.)	1795 (70.67 in.)	1795 (70.67 in.)	1756 (69.13 in.)	1764 (69.45 in.)
Overall width	640 (25.19 in.)	640 (25.19 in.)	640 (25.19 in.)	610 (24.02 in.)	615 (24.21 in.)
Overall height	975 (38.4 in.)	975 (38.4 in.)	975 (38.4 in.)	910 (35.83 in.)	913 (35.95 in.)
Wheelbase	1185 (46.65 in.)	1185 (46.65 in.)	1185 (46.65 in.)	1150 (45.28 in.)	1150 (45.28 in.)
Min. ground clearance	130 (5.12 in.)	130 (5.12 in.)	130 (5.12 in.)	125 (4.92 in.)	125 (4.92 in.)
Weight, kg					
Weight, empty	69 (152 lb)	75.5 (166.6 lb)	73 [80] (161, 174 lb)	77.5 (170 lb)	76.5 (168 lb)
Empty weight distribution, front	30 (66.2 lb)	33 (72.8 lb)	31.5 [33.5] (69.3, 73.6 lb)	34.0 (75 lb)	33.5 (73.5 lb)
Empty weight distribution, rear	39 (86.1 lb)	42.5 (93.8 lb)	41.5 [45.5] (91.3, 100 lb)	43.5 (95.5 lb)	43 (94.5 lb)
Full load weight distribution, front	50.5 (111.5 lb)	54 (119.1 lb)	55.5 [55.8] (122, 123 lb)	55 (121 lb)	53.5 (118 lb)
Full load weight distribution, rear	73.5 (162.2 lb)	76.5 (169 lb)	127.5 [135] (280, 297 lb)	132.5 (291 lb)	78 (172 lb)
Performance					
Max. speed	75 km/h (47 mile/h)	75 km/h (47 mph)	85 km/h (53 mph)	90 km/h (56 mph)	85 km/h (53 mph)
Acceleration from dead start: 0-200m				12.7 Sec.	14.3 Sec.
Acceleration from dead start: 0-400m					
Stopping distance	Max. 5m (16.5ft) from 20 km/h (13.9 mph)	Same as left	Max. 7 m (23 ft) from 35 km/h (21.8 mph)	Same as left	Max. 5m (16.4ft) from 20 km/h (12.4 mph)
Fuel consumption: (km/ℓ mi/U.S. Gal.)	90 km/ℓ (228 mi/U.S. gal) (254 mi/Imp gal) @25 km/h (15.6 mph)	Same as left	85 km/ℓ (215 mi/U.S. gal) (240 mi/Imp gal) @30 km/h (18.7 mph)	Same as left	90 km/ℓ (210 mi/U.S. gal) (252 mi/Imp gal) @25 km/h (15.5mph)
Climing ability: grade	14°	14°	17°30'	17°30'	14°
Noise output during driving: phon			35 kph (21.8 mph) / 67 phon, A grade	35 kph (21.8 mph) / 68 phon, A grade	35 kph (21.8 mph) / 70 phon, max. A grade

Note: [] is for C65M.

	C50	C50M	C65, C65M	S65	S50
Noise output at rear of exhaust pipe : phon			5400 rpm/50 phon, A grade	6000 rpm/60 phon, A grade	
Min. turning radius	1.80 m (70.8 in.)	1.80 m (70.8 in.)	1.80 m (70.8 in.)	1.96 m (77.17 in.)	1.74 m (68.50 in.)
Engine					
Name and model	C50E	C50E	C65E (C65E)	S65E	S50E
Manufacturer	Honda Motor Co., Ltd., Suzuka Factory	Same as left	Same as left	Same as left	Same as left
Type fuel used	Gasoline	Gasoline	Gasoline	Gasoline	Gasoline
Type engine	Air cooled 4 stroke cycle	Air cooled 4 stroke cycle	Air cooled 4 stroke cycle	Air cooled 4 stroke cycle	Air cooled 4 stroke cycle
No. of cylinder and arrangement	Single cylinder, tilted up 10° from horizontal	Same as left	Single cylinder, tilted up 10° from horizontal	Same as left	Single cylinder, tilted forward 80°
Valve arrangement	Overhead valve	Overhead valve	Overhead valve	Overhead valve	Overhead valve
Total piston displacement	49 cc (3.00 cu in.)	49 cc (3.00 cu in.)	63 cc	63 cc	49 cc
Bore X stroke	39 X 41.4 (1.44 X 1.63 in.)	39 X 41.4 (1.44 X 1.63 in.)	44 X 41.4 (1.73 X 1.63 in.)	44 X 41.4 (1.73 X 1.63 in.)	39 X 41.4 (1.54 X 1.63 in.)
Compression ratio	8.8	8.8	8.8	8.8	8.8
Compression pressure :	12kg/cm ² @1000rpm (170 lb/in. ² @1000 rpm)	12kg/cm ² @1000rpm (170 lb/in. ² @1000 rpm)	12kg/cm ² @1000rpm (170 lb/in. ² @1000 rpm)	12kg/cm ² @1000rpm (170 lb/in. ² @1000 rpm)	12kg/cm ² @1000rpm (170 lb/in. ² @1000 rpm)
Max. output	4.8 PS/10000 rpm	4.8 PS/10000 rpm	5.5P.S./9000 rpm	6.22 P.S./10000 rpm	5.2 P.S./10250 rpm
Max. torque	0.37 kg-m/8200 rpm (2.7 ft-lb/8200 rpm)	0.37 kg-m/8200 rpm (2.7 ft-lb/8200 rpm)	0.46 kg-m/7000 rpm (3.32ft-lb/7000 rpm)	0.485 kg-m/8500 rpm (3.47 ft-lb/8500 rpm)	0.38 kg-m/9000 rpm (2.75ft-lb/9000 rpm)
Min. fuel consumption at max. load	250 g/PS-h/8200 rpm	250 g/PS-h/8200 rpm	250g/P.S-h/7000rpm	250g/P.S-h/7500rpm	250g/P.S-h/8000rpm
Dimension mm	451 ℓ X 355w X 291h	451 ℓ X 371w X 291h	451 ℓ X 371w X 288h (355) (17.8 X 14.6 X 11.3) (14.0)	432 ℓ X 348w X 331h (17.0 X 13.7 X 13.0)	432 ℓ X 348w X 366h (17.0 X 13.7 X 14.4)
Total weight	18 kg (39.616)	21.2 kg (25 lb)	18 kg (39.6lb) [21.2 (46.6lb)]	17.9 kg (39.4lb)	18 kg (39.6lb)
Installation and method	On frame center bolted from bottom	Same as left	Same as left	Same as left	Same as left
Starting method	Kick starter	Kick starter, starting motor	Kick starter (also starting motor)	Kick starter	Kick starter
Fuel system					
Carburetor No. and type	DP13N13 X 1	DP13N13 X 1	DP13N14 X 1	PW18 X 1	PW17 X 1
Manufacturer	Keihin Seiki	Keihin Seiki, Mikuni Kogyo	Keihin Seiki	Keihin Seiki, Mikuni Kogyo	Same as left
Air filter type	Dry filter element	Same as left	Dry filter element	Same as left	Same as left
Manufacturer	Tokyo Roki	Tokyo Roki	Tokyo Roki	Tokyo Roki, Tsuchiya Seisakusho	Tokyo Roki, Tsuchiya Seisakusho
Fuel pump type					
Manufacturer					
Fuel tank capacity	3.0 ℓ (6.3 U.S pt) (5.3 Imp pt)	3.0 ℓ (6.3 U.S pt) (5.3 Imp pt)	4.5 ℓ (9.5 U.S pt) (7.9 Imp pt)	6.5 ℓ (13.7 U.S pt) (11.4 Imp pt)	5.5 ℓ (11.6 U.S pt) (9.7 Imp pt)
Lubrication system					
Lubricating method	Pressure and splash	Same as left	Same as left	Same as left	Same as left
Type pump	Gear pump	Gear pump	Gear pump	Gear pump	Gear pump
Type oil filter	Screen and centrifugal filter	Same as left	Same as left	Same as left	Same as left
Lubrication system capacity	0.8 ℓ (1.7 U.S pt) (1.4 Imp pt)	Same as left	0.8 ℓ (1.7 U.S pt) (1.4 Imp pt)	Same as left	Same as left

	C50	C50M	C65, C65M	S65	S50
Ignition system					
Ignition method	High voltage electrical spark	Same as left	High voltage electrical spark	Same as left	Same as left
Type ignition coil	CM61-08	M61-03B	J390356 (HDAA 295) [M61-03B]	J390356	J390356
Manufacturer	Hitachi Seisakusho	Hitachi Seisakusho	Mitsubishi Denki, Nippon Denso Hitachi Seisakusho	Mitsubishi, Kokusan, Denso	Mitsubishi, Kokusan, Denso
Type spark plug	C-7HS U22FW	Same as left	C-7HS U22FW	Same as left	Same as left
Manufacturer	Nippon Tokushu Toki Denso	Same as left	Nippon Tokushu Toki Denso	Same as left	Same as left
Electrical system					
Battery No. and type	G2H, MBC1-6, 1 each	MBQ8-6, 1 each	MBC1-6, 1 each [MBQ8-6, 1 each]	G 2H or MBC 1-6, 1 each	G 2H or MBC 1-6, 1 each
Volt and AH	6-2	6-11	6-2 [6V-11AH]	6-2	6-2
Manufacturer	Yuasa battery	Yuasa Battery	Yuasa Battery	Yuasa Battery	Yuasa Battery
Type generator	F120	HO (6084)-ROT-ST	FAZ [HO (6084) ROT-ST]		
Manufacturer	Hitachi Seisakusho	Same as left	Mitsubishi Denki [Hitachi Seisakusho]	Same as left	Same as left
Type starting motor		SM-1	[SM-1]		
Manufacturer		Mitsuba Denki	[Mitsuba Denki]		
Type rectifier	Selenium	Same as left	Selenium	Same as left	Same as left
Manufacturer			Shin Dengen Kogyo	Same as left	Same as left
Power transmission system					
Primary reduction method	Gear	Gear	Gear	Gear	Gear
Reduction ratio	3,722	3,722	3,300	3,300	3,300
Clutch type	Automatic wet multiple disc centrifugal type	Same as left	Automatic wet multiple disc centrifugal type	Wet multiple disc type	Wet multiple disc type
Type transmission	Constant meshed gears	Same as left	Constant meshed gears	Same as left	Same as left
Gear change method	Left foot operated fore and aft	Same as left	Left foot operated fore and aft	Left foot operated rotary type	Left foot operated rotary type
Oil capacity					
Gear ratio, 1st gear	3.364	3.364	3.364	30.00	30.00
Gear ratio, 2nd gear	1.722	1.722	1.722	17.65	17.65
Gear ratio, 3rd gear	1.190	1.190	1.190	13.00	13.00
Gear ratio, 4th gear				10.43	10.43
Secondary reduction method	Chain and sprocket	Same as left	Chain and sprocket	Same as left	Same as left
Reduction ratio	3.000	3.000	3.154	33.08	31.54
Total gear ratio			12.4 (12.4)	11.4 (11.4)	12.2 (12.2)
Steering system					
Steering handle turning radius	45°	45°	45°	43°	43°

	C50	C50M	C65, C65M	S65	S50
Steering handle width	632 mm (24.9 in.)	632 mm (24.9 in.)	632 mm (24.9 in.)	605 mm (23.79 in.)	605 mm (23.79 in.)
Caster	63°	63°	63°	63°	63°
Trail	75 mm (2.95 in.)	75 mm (2.95 in.)	75 mm (2.95 in.)	75 mm (2.95 in.)	75 mm (2.95 in.)
Tire, front	2.25-17 (4PR)	2.25-17 (4PR)	2.25-17 (4PR)	2.25-17 (4PR)	2.25-17 (4PR)
Tire, rear	2.25-17 (4PR)	2.25-17 (4PR)	2.25-17 (4PR)	2.25-17 (4PR)	2.25-17 (4PR)
Brake system					
Type brake, front	Internal expanding shoe	Same as left	Internal expanding shoe	Same as left	Same as left
Type brake, rear	Internal expanding shoe	Same as left	Internal expanding shoe	Same as left	Same as left
Method of application, front	Right hand lever operated	Same as left	Right hand lever operated	Same as left	Same as left
Method of application, rear	Right foot pedal operated	Same as left	Right foot pedal operated	Same as left	Same as left
Suspension system					
Suspension method, front	Bottom link system	Same as left	Bottom link type	Same as left	Same as left
Suspension method, rear	Swing arm type	Same as left	Swing arm type	Same as left	Same as left
Dampening system, front	Hydraulic	Same as left	Hydraulic	Same as left	Same as left
Dampening system, rear	Hydraulic	Same as left	Hydraulic	Same as left	Same as left
Frame type	Backbone type	Same as left	Backbone type	Backbone type	Backbone type
Lighting system					
Headlamp type	ASS11	ASS11	ASS11		C-2H
Manufacturer	Stanley Denki	Stanley Denki	Stanley Denki	Stanley Denki	Stanley Denki
Headlamp rating	6V-15W/15W	6V-25W/25W	6V-15W/15W [6V-25W/25W]	9V-15W/15W	6V-15W/15W
Taillamp rating	6V-3W	6V-3W	6V-3W	6V-2W	6V-2W
Taillamp combination with	License plate	License plate	License plate	License plate	License plate
Stop lamp rating, color	6V-10W red	6V-10W red	6V-10W red	6V-6W red	6V-6W red
Stop lamp combination with					
Turn signal type	Magnetic, heating element	Same as left	Magnetic, heating element	Same as left	Same as left
Turn signal rating, color	6V-8W×2 amber	6V-8W×2 amber	6V-8W×2 amber	6V-8W×2 amber	6V-8W×2 amber
Turn signal combination with	6V-1.5W	6V-1.5W			
Instrument					
Horn type	Electric flat type	Same as left	Electric flat type	Same as left	Same as left
Manufacturer	Imasen Denki, Mitsuba Denki	Same as left	Imasen Denki, Mitsuba Denki	Same as left	Same as left
Speedometer type	Magnetically driven	Same as left	Magnetically driven	Same as left	Same as left
Manufacturer	Nippon Seiki, Nippon Denso	Same as left	Nippon Seiki, Nippon Denso	Same as left	Same as left
Rear view mirror, type			Magnetically driven		
Manufacturer			Stanley Denki	Same as left	Same as left
Method of installation					

Engine Performance (C 50)

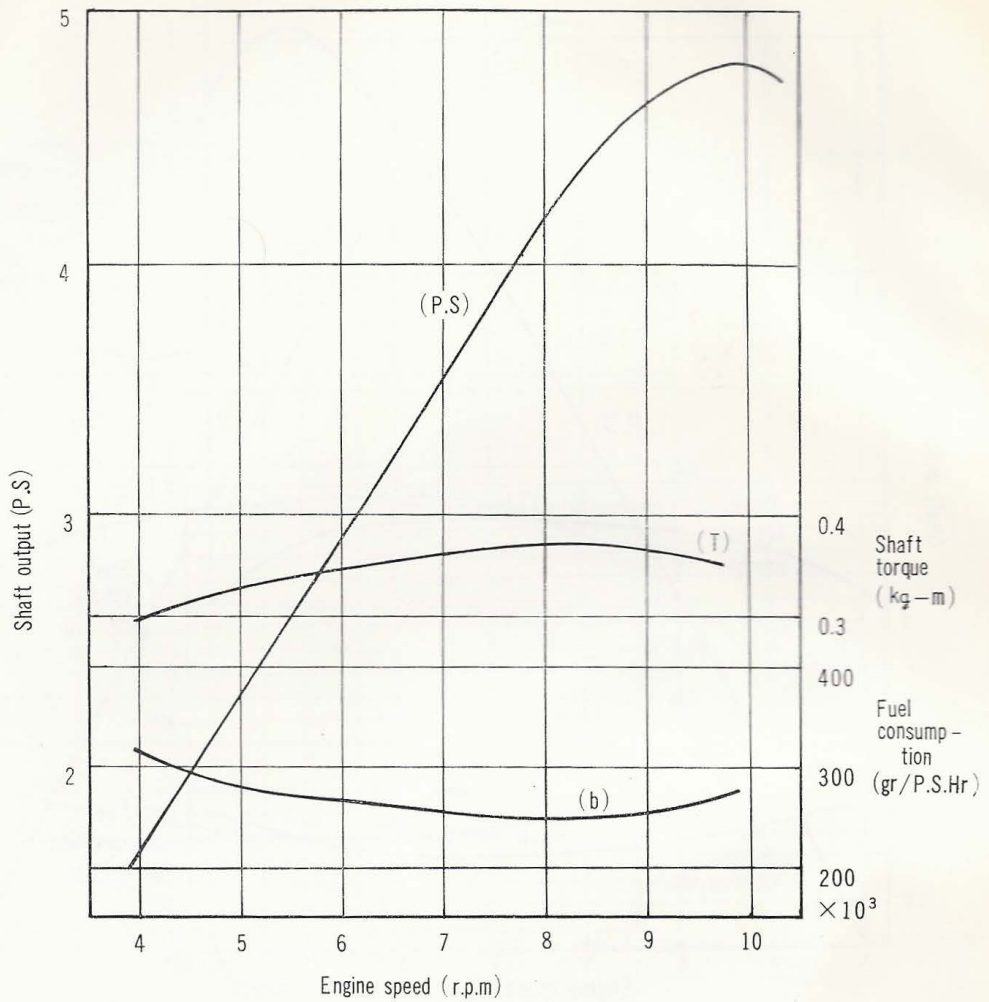

Running Performance (C 50)

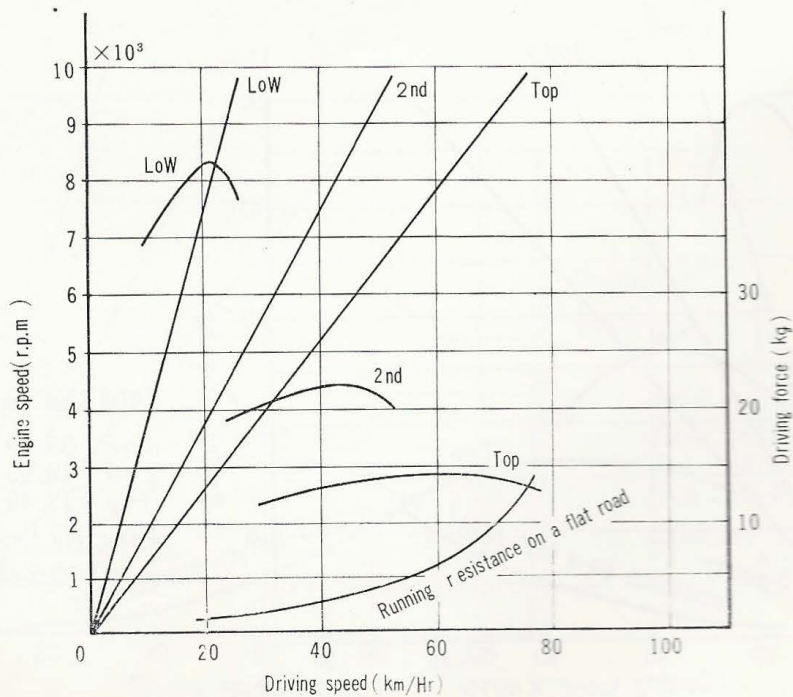

Engine Performance (C 65)

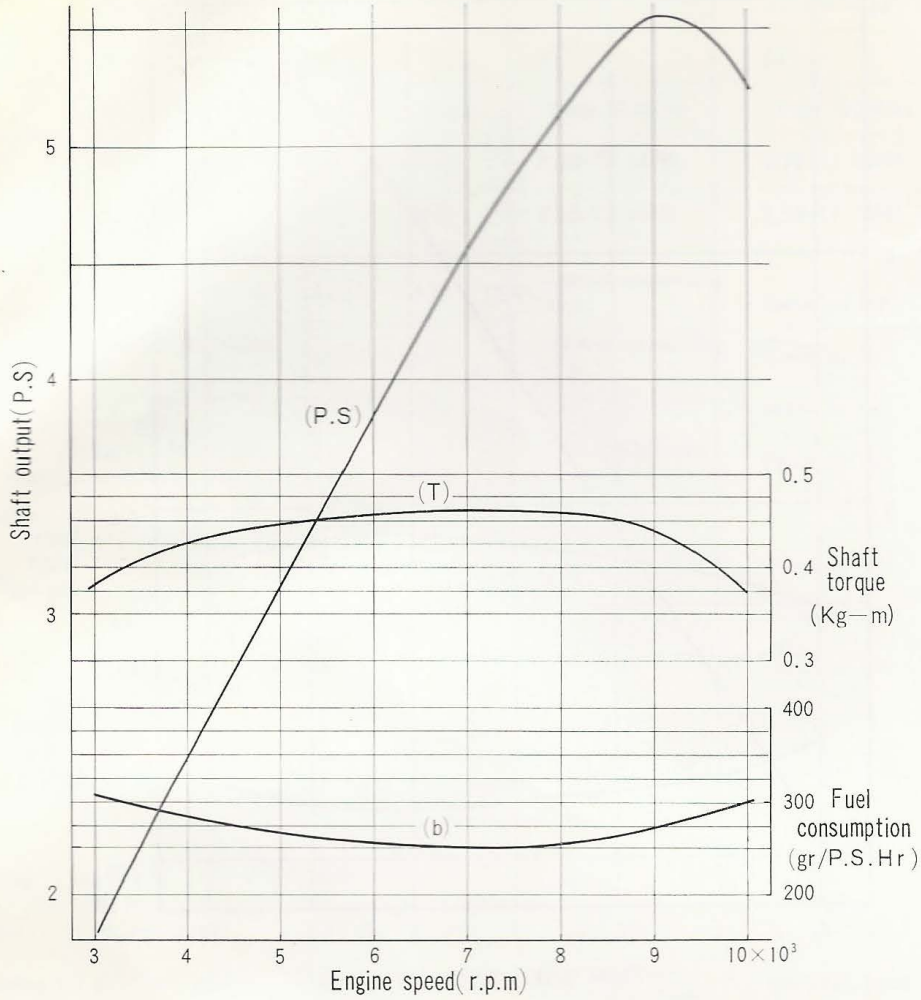

Running Performance (C 65)

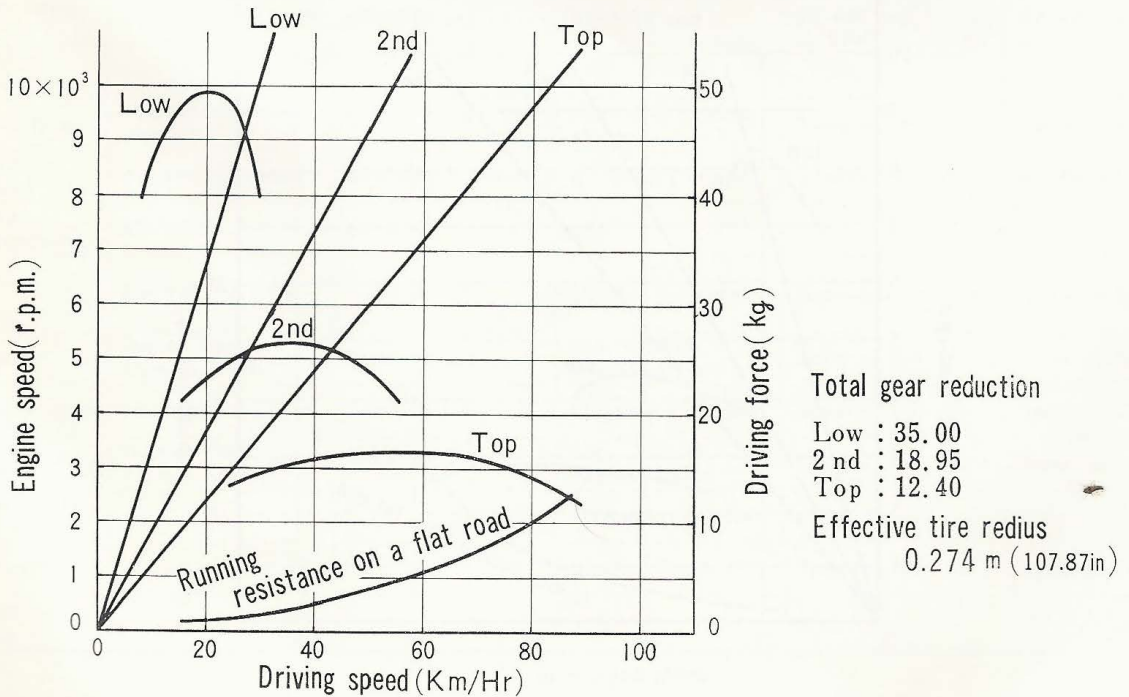

Engine Performance (C 65 M)

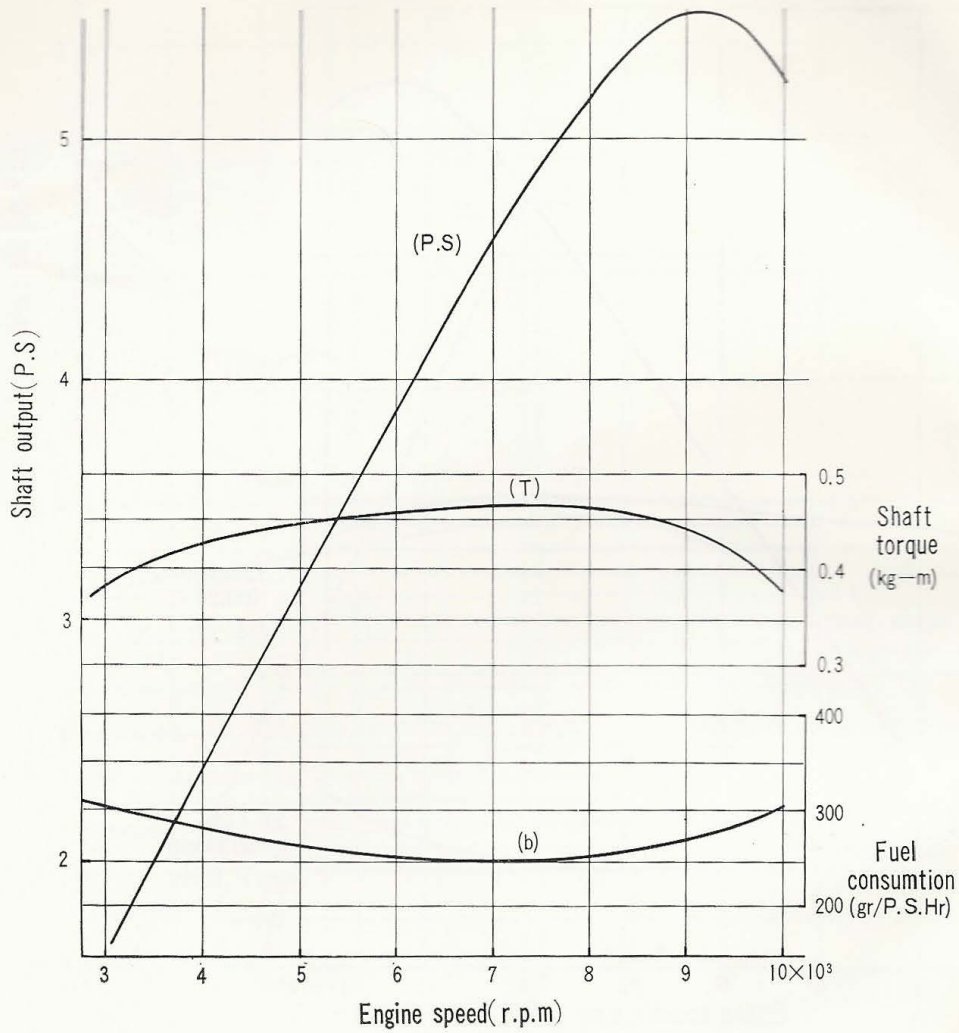

Running Performance (C 65 M)

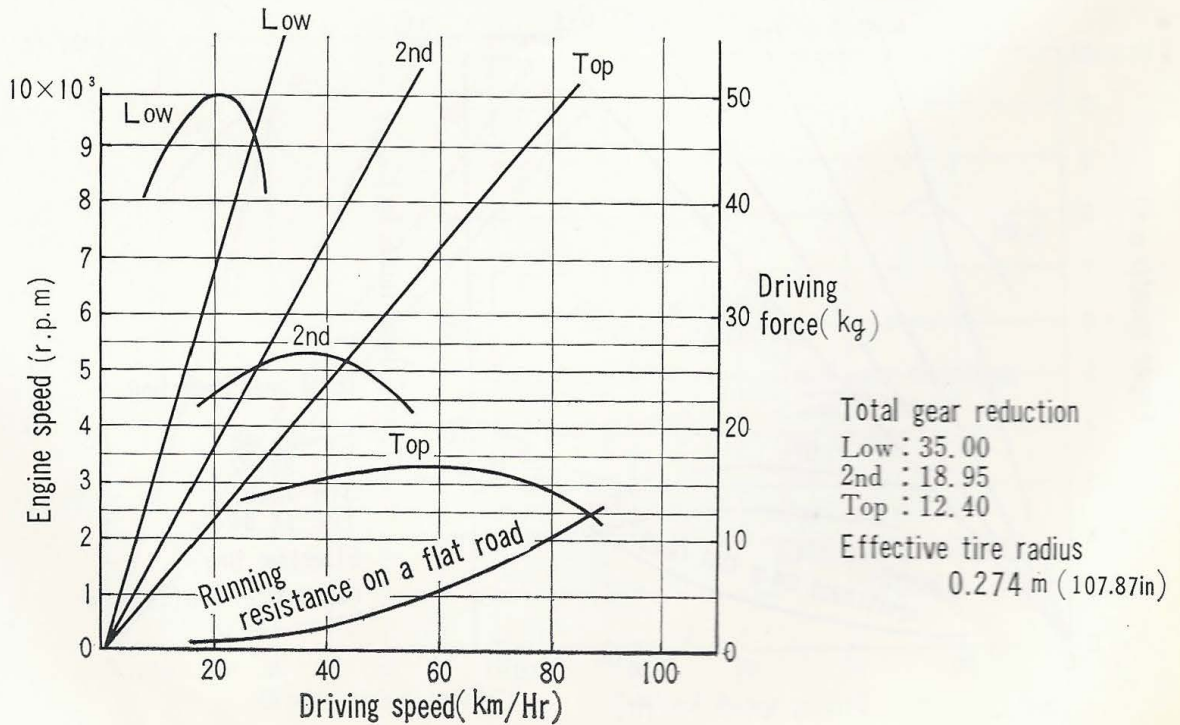

Engine Performance (S 50)

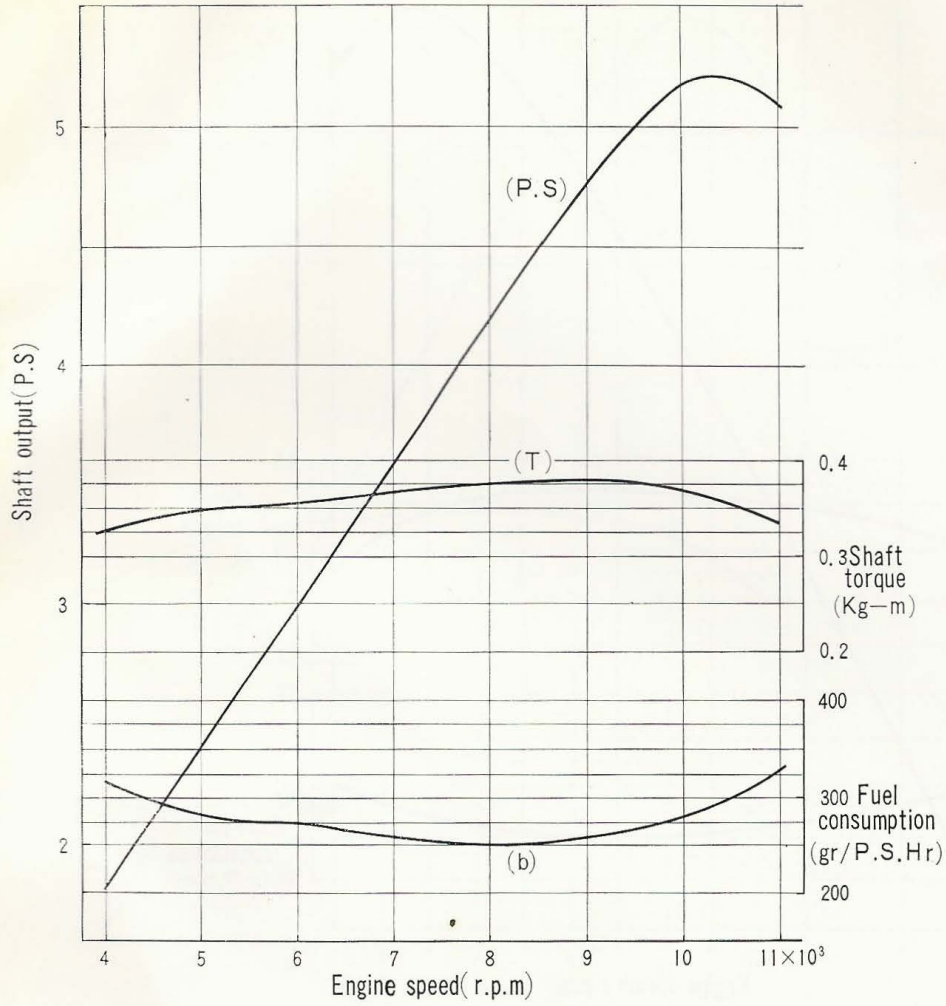

Running Performance (S 50)

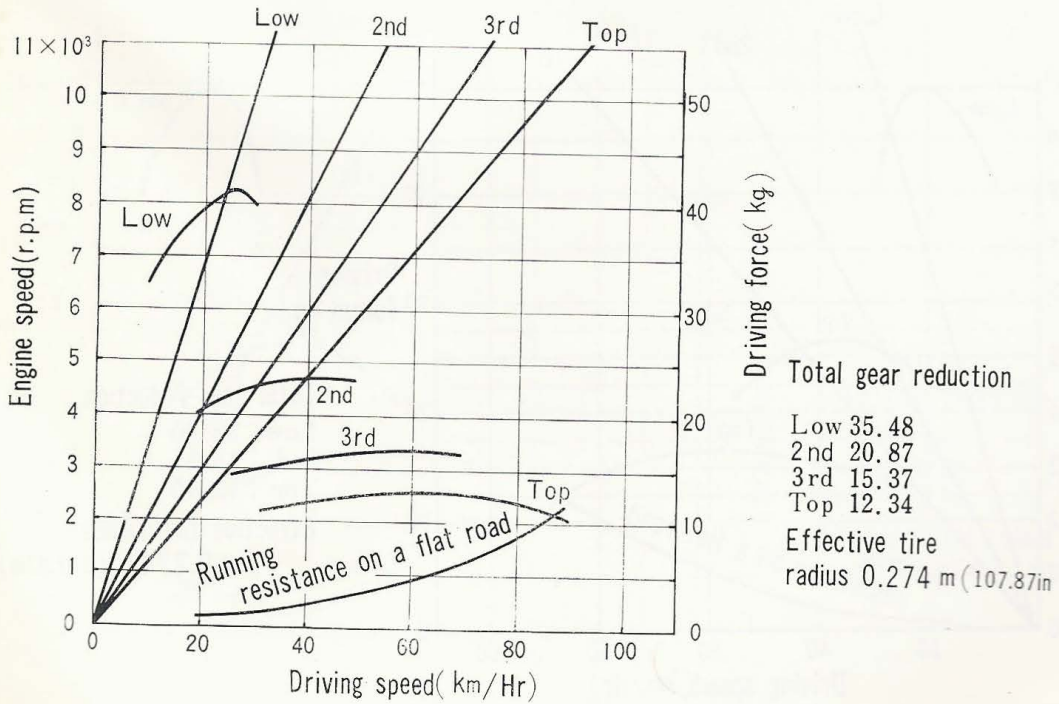

Engine Performance (S 65)

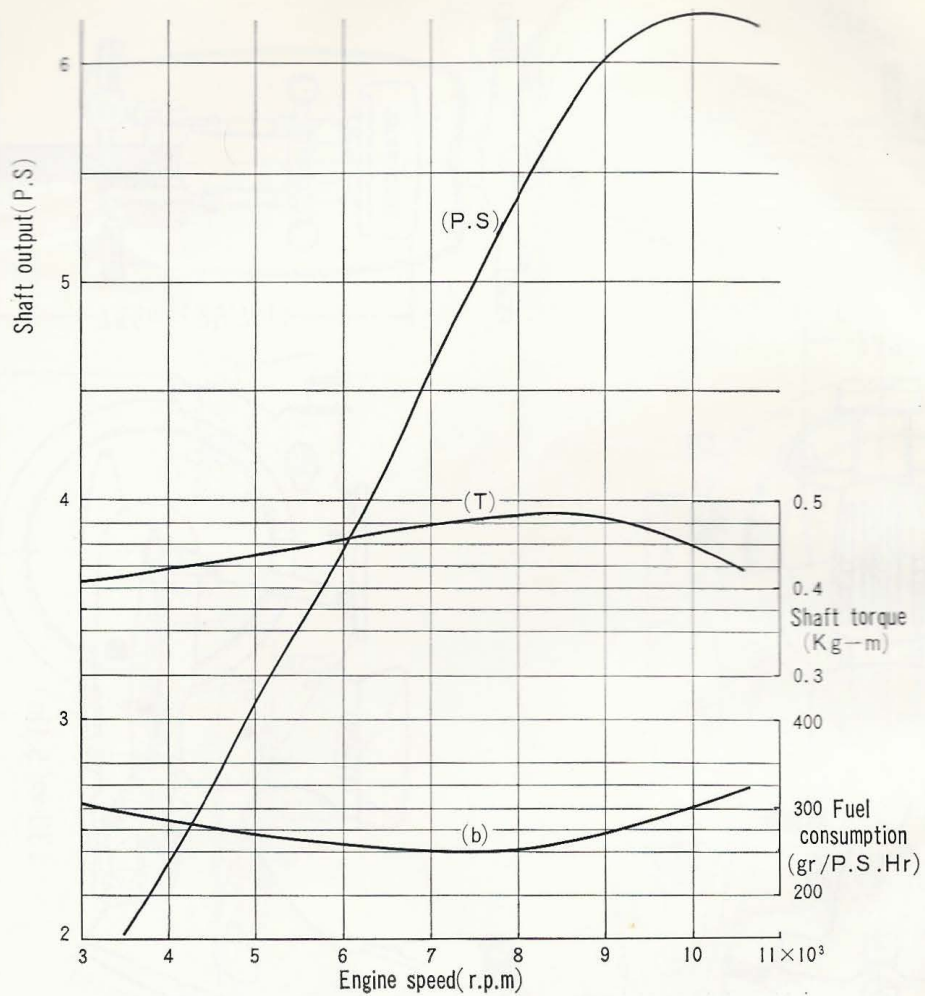

Running Performance (S 65)

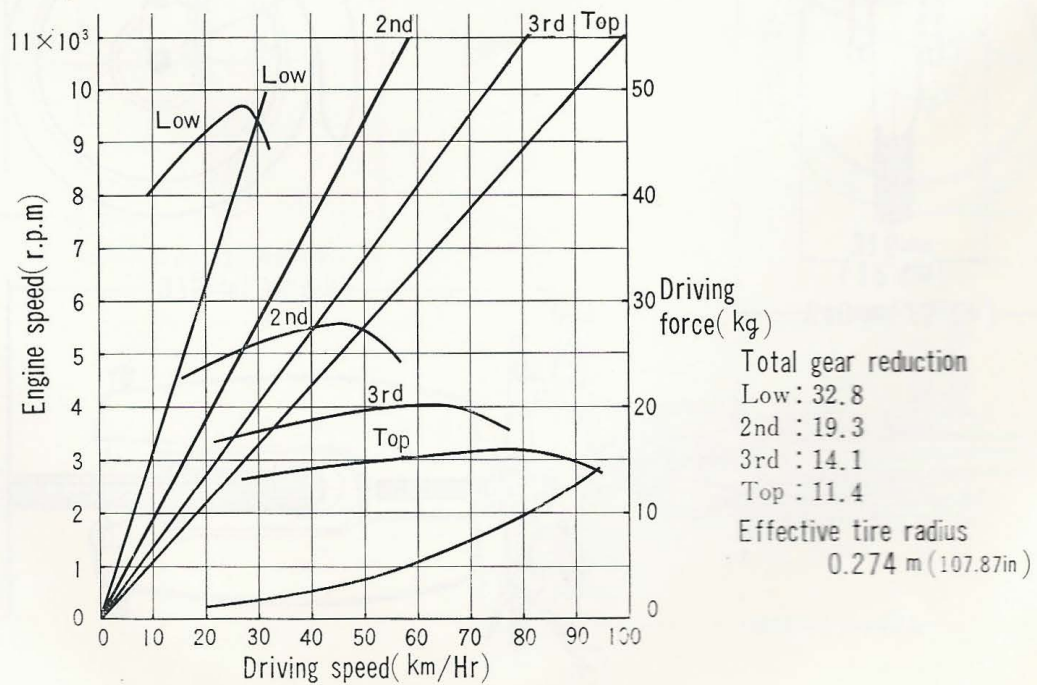

DIMENSIONAL DRAWING

NAME: HONDA
MODEL: C50, C65

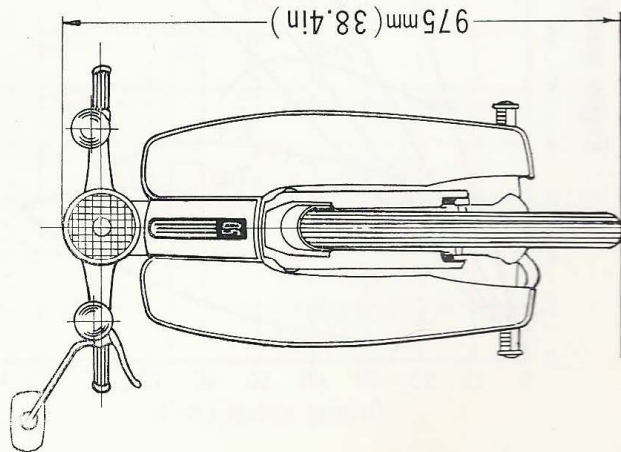
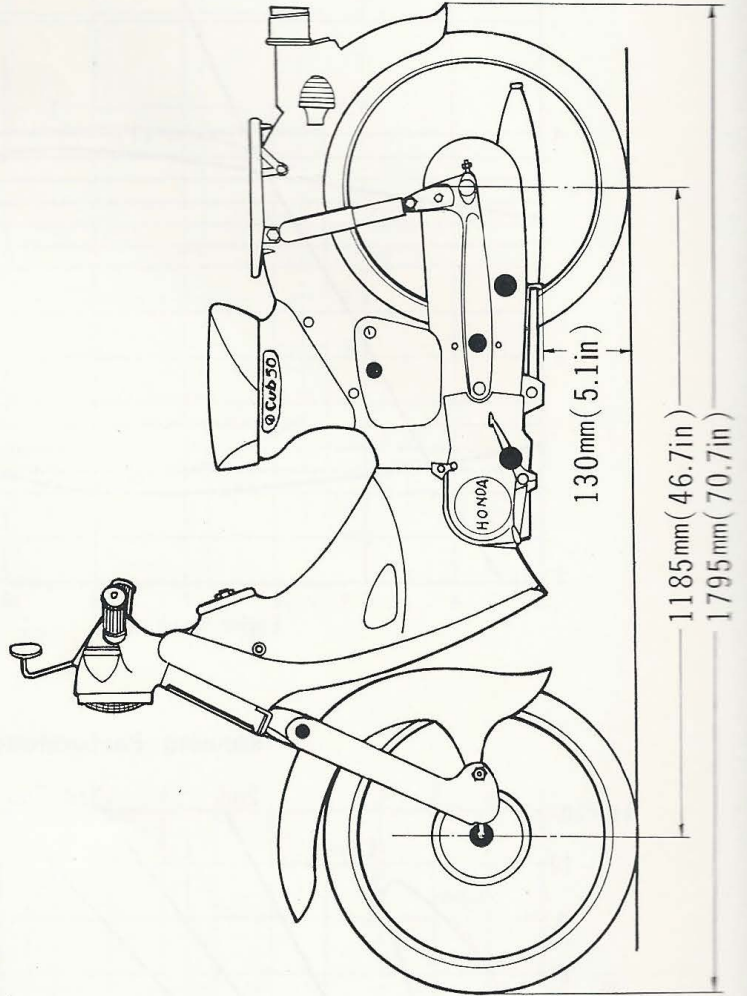
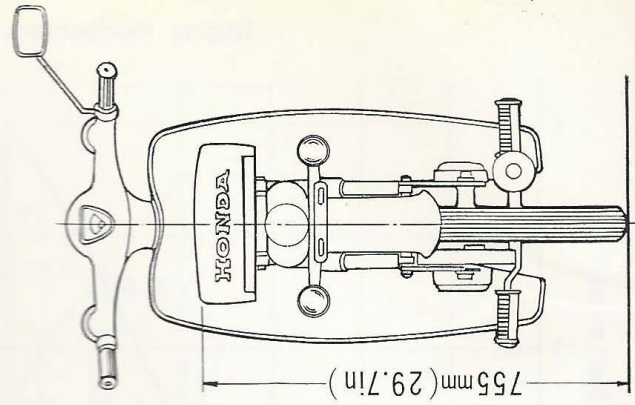
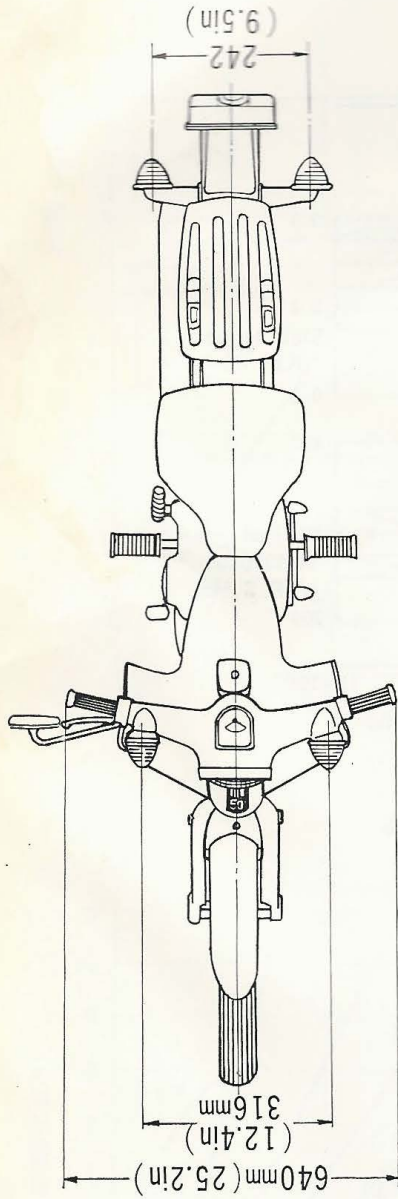

DIMENSIONAL DRAWING

NAME : HONDA

MODEL : S65

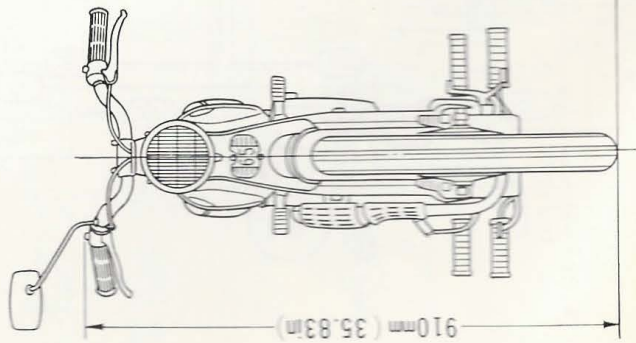
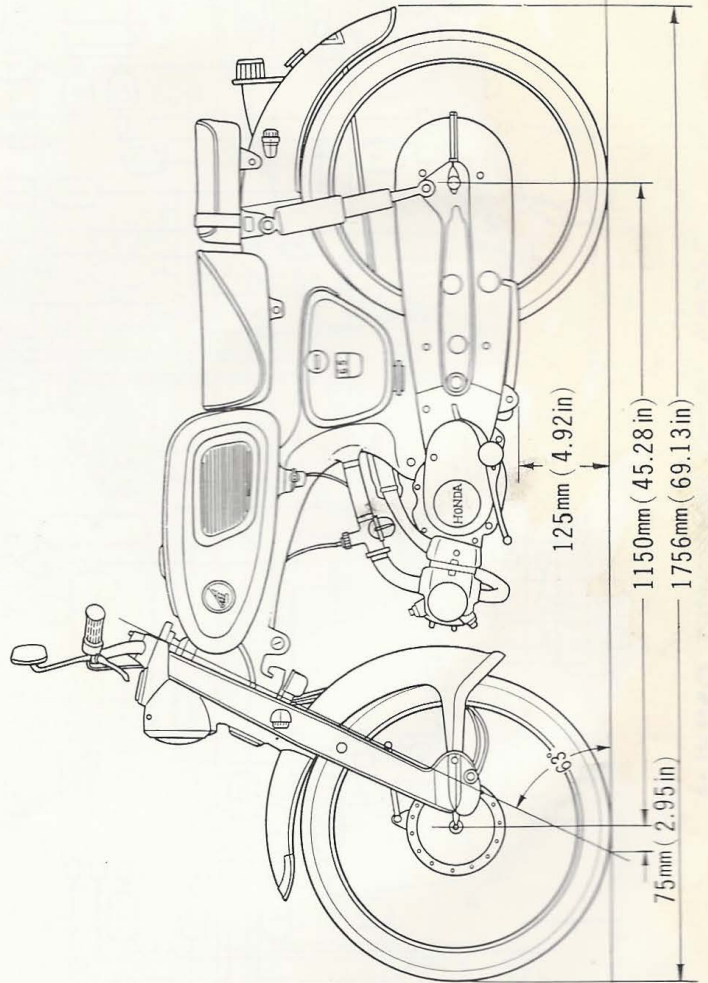
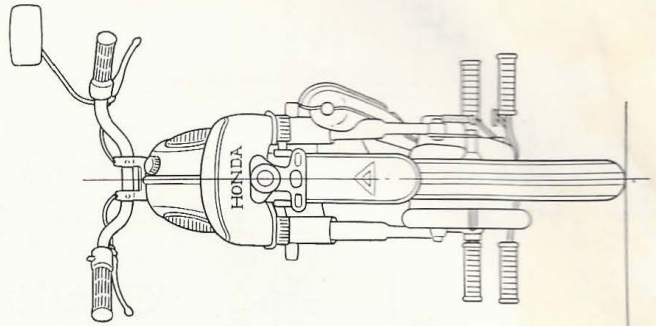
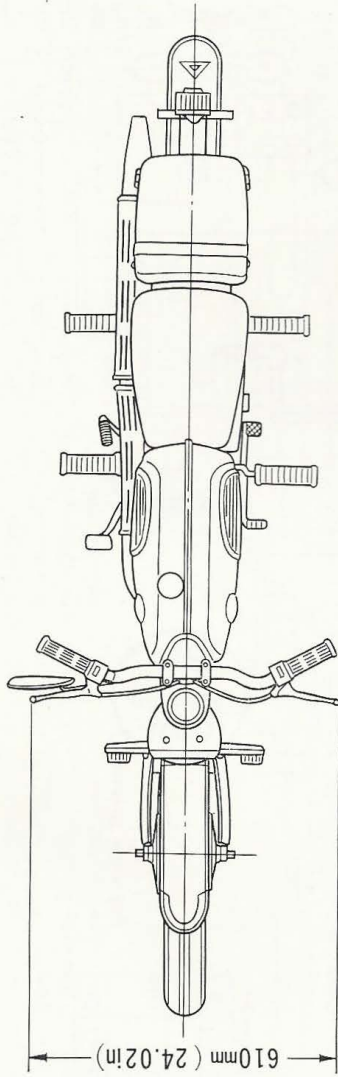

WIRING DIAGRAM (C50, C65)

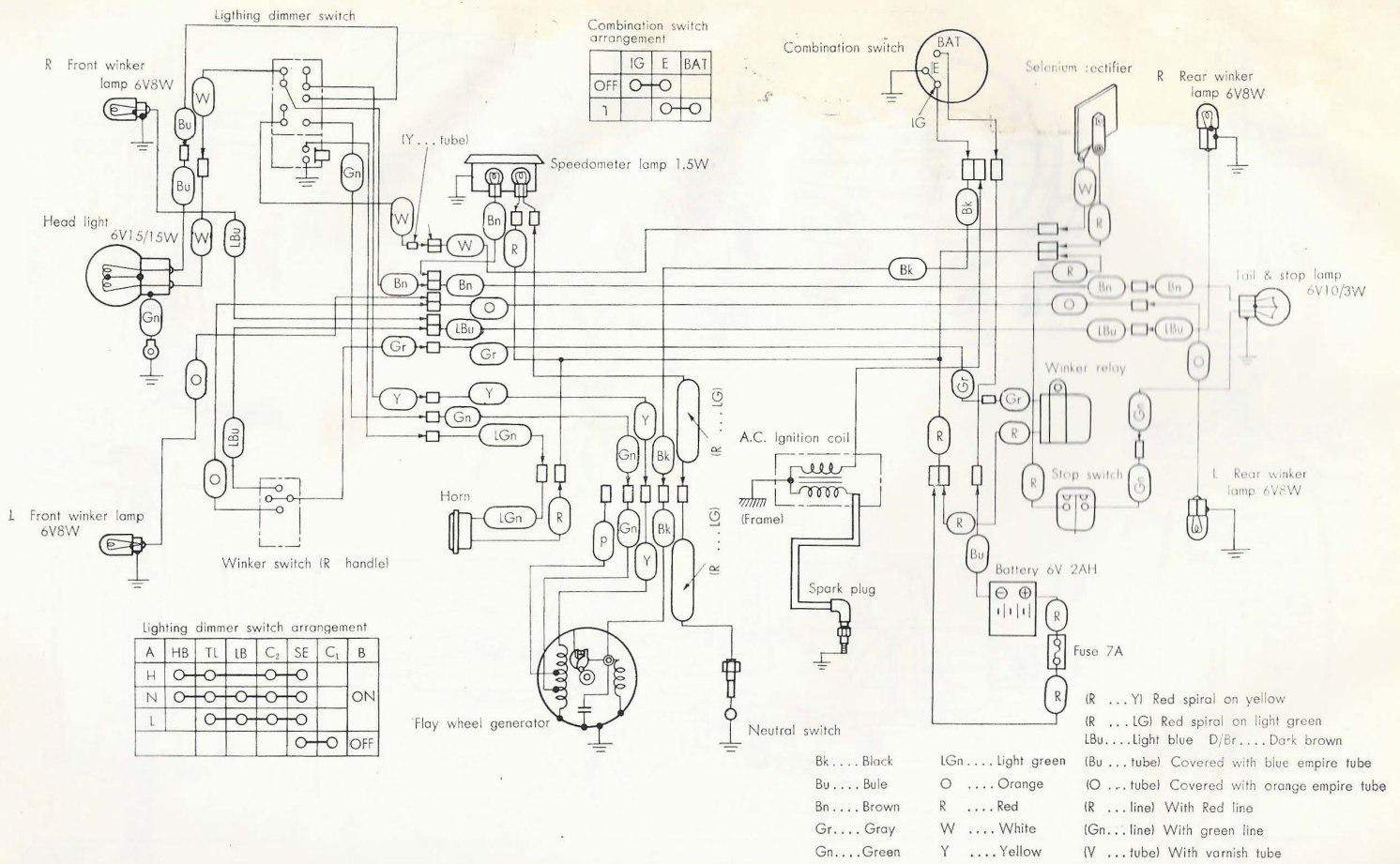

DIREKTORAT DEVALE

WIRING DIAGRAM (S50 · S65)

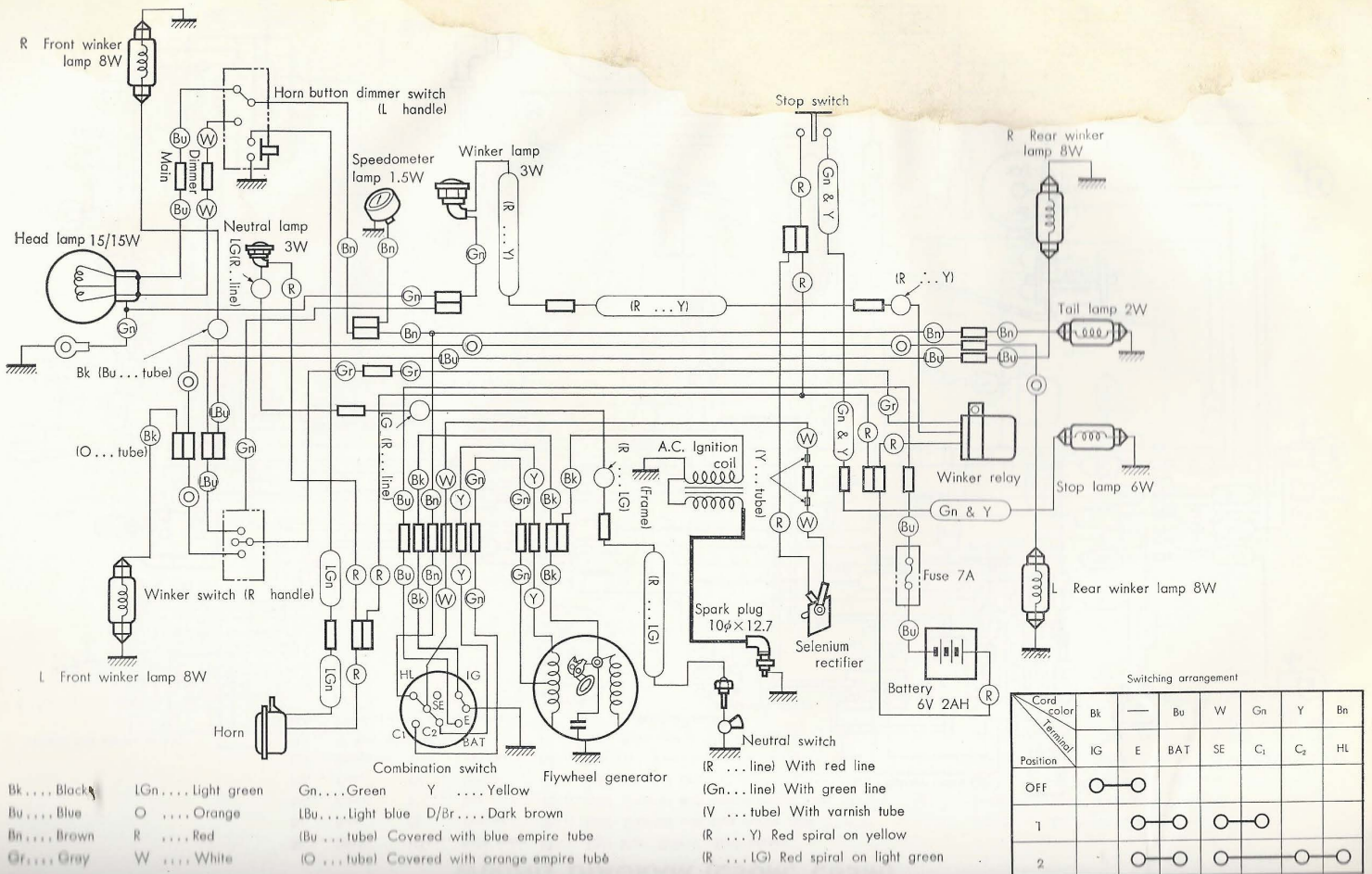

Honda 50-65 Series Models C50, C50M, C65, C65M, S50 and S65
SHOP MANUAL

Published by

HONDA MOTOR CO., LTD.

Foreign Service Department

SERVICE DIVISION

4429-1 Niikura Yamato-Machi Saitama-Ken, Japan

Printed by YAMAGATA PRINTING CO., LTD.

6-34, 2-chome, Takashima, Nishi-ku,
Yokohama, Japan

December, 1966

Copyright reserved



HONDA MOTOR CO., LTD.